



Education and Culture

Leonardo da Vinci

**DESIGN OF STRUCTURAL CONNECTIONS
TO EUROCODE 3
FREQUENTLY ASKED QUESTIONS**



Watford, September 2003

Building Research Establishment, Ltd.



Education and Culture

Leonardo da Vinci

Design of Structural Connections to Eurocode 3 – Frequently Asked Questions

Ed. Moore D.B., Wald F.

www.fsv.cvut.cz/cestruco

ISBN 80-01-02838-0

Building Research Establishment Ltd, Watford

Printed at Prod. Dept. of Publishing House of Czech Technical University in Prague

September 2003

1500 copies, 140 pages, 154 figures

Textbook, Work Package Dissemination

Project Continuing Education in Structural Connections

No. CZ/00/B/F/PP-134049

LEONARDO DA VINCI PROGRAMME

This project has been carried out with the support of the European Community.

The content of this project does not necessarily reflect the position of the European Community or the National Agency, nor does it involve any responsibility on their part.

LIST OF CONTENTS

	Page
1 Introduction	6
2 Bolts	10
Q&A 2.1 Loss of Bolt Pre-Load	12
Q&A 2.2 Bearing of Slip Resistant Connections	12
Q&A 2.3 Shear Resistance of Pre-Loaded Bolts Carrying a Tension Force	13
Q&A 2.4 Maximum Bolt End and Edge Distances	13
Q&A 2.5 Deformation Criteria for Bolt Bearing Resistance	14
Q&A 2.6 End and Edge Bolt Distances	15
Q&A 2.7 Bearing Resistance of Bolt Group	15
Q&A 2.8 Bearing Resistance in Slotted Holes	16
Q&A 2.9 Design Method for Fitted Bolts	17
Q&A 2.10 Combined Shear and Tension	18
Q&A 2.11 Resistance of Connections Using High-Strength Steel	19
3 Welding	20
Q&A 3.1 Connecting Two Angles to Gusset Plate	22
Q&A 3.2 Effective Width of Welded Beam-to-Column Connection	23
Q&A 3.3 Throat Thickness of a Fillet Weld used in a Hollow Section Joints	24
Q&A 3.4 Modelling the Resistance of a Fillet Weld	24
Q&A 3.5 Design of Partially Penetrated Butt Weld	25
Q&A 3.6 Weld Design for Full Resistance of Connecting Members	26
4 Structural Modelling	27
Q&A 4.1 Preliminary Design of Connections	29
Q&A 4.2 Use of Elastic Theory for Global Analysis of Structures	29
Q&A 4.3 Classification Criteria for Column Bases	31
Q&A 4.4 Design of Connections Loaded by Low Forces	32
Q&A 4.5 Modelling of Joint Eccentricity in Frame Design	33
5 Simple Connections	35
Q&A 5.1 Bolt Bearing Resistance with Respect to Tolerances	41
Q&A 5.2 Angles Connected by One or Two Bolts	42
Q&A 5.3 Rotation Capacity	43
Q&A 5.4 Structural Integrity	44
6 Moment Connections	46
Q&A 6.1 Stiffness Modification Coefficient for End-Plate Connections	49
Q&A 6.2 Effective Length of Stiffened T-stub	50
Q&A 6.3 Haunched Connections	51
Q&A 6.4 Diagonal and K-stiffeners	51
Q&A 6.5 Field line Patterns for End Plate Connection with Four Bolts in a Row	52
Q&A 6.6 Distribution of Forces in a Thick End Plate Connection	53
Q&A 6.7 Distribution of Shear Forces in a Bolted Connection	54
Q&A 6.8 Bending Force of T-stub in Fatigue Design	54
Q&A 6.9 Joints Loaded by Bending Moment and Axial Force	56
Q&A 6.10 Stiffening of the Column Web Panel with a Morris Stiffener	60

	Page
7 Column Bases	62
Q&A 7.1 Elastic Resistance of Base Plate	63
Q&A 7.2 Base Plate Resistance with Low Quality Grout	64
Q&A 7.3 Comparison of Concrete Strength Calculation according to EC2 and EC3	64
Q&A 7.4 Stress Concentration under the Base Plate	66
Q&A 7.5 Effective Length of a Base Plate T-stub	67
Q&A 7.6 Base Plates with Bolts outside the Column Flange	69
Q&A 7.7 Slip Factor between Steel and Concrete	71
Q&A 7.8 Transfer of Shear Forces by Anchor Bolts	72
Q&A 7.9 Transfer of Shear Forces by Friction and Anchor Bolts	73
Q&A 7.10 Anchorage Rules for Holding Down Bolts	73
8 Seismic Design	76
Q&A 8.1 Connections Subject to Dynamic Load	80
Q&A 8.2 Influence of Unsymmetrical Loading	81
Q&A 8.3 Influence of Strain-Rate Loading	81
Q&A 8.4 Welding Technology	81
Q&A 8.5 High Strength Bolts in Seismic Joints	82
Q&A 8.6 Column Web Panel	83
9 Fire Design	84
Q&A 9.1 Bolts Resistance at High Temperature	84
Q&A 9.2 Weld Resistance at High Temperature	85
Q&A 9.3 Temperature Distribution with Time within a Joint	85
Q&A 9.4 Component Method under High Temperatures	87
10 Hollow Section Connections	90
Q&A 10.1 Circular Hollow Section Joints	92
Q&A 10.2 Rectangular Hollow Section Joints	94
Q&A 10.3 Joints between Hollow and Open Section Members	96
Q&A 10.4 Design Charts	98
Q&A 10.5 Blind Bolting	100
Q&A 10.6 Hollow Section Joints using High Strength Steel	102
Q&A 10.7 Offshore Construction	102
11 Cold-Formed Connections	103
Q&A 11.1 Increased Yield Strength by Cold-Forming	108
Q&A 11.2 Deformation Capacity of Shear Connections	109
Q&A 11.3 Screws in Sandwich Panels	109
Q&A 11.4 Bearing of Thin Plates	110
12 Aluminium Connections	111
Q&A 12.1 Resistance of Fillet Welds	111
Q&A 12.2 Effective Width and Throat Thickness of Fillet Welds	112
Q&A 12.3 Butt Welds in Aluminium Joints	113
Q&A 12.4 Heat Affected Zones	114
13 Good and Bad Detailing	117
14 Lessons on Internet/CD	123
15 Text of PowerPoint Lesson on the Design of Connections for Fire Safety	125
List of Symbols	128
References	134

1 Introduction

Developments in the design, fabrication and erection of steel structures together with the introduction of new high performance materials have led to significant changes in the design, buildability and performance of steel structures and in particular their connections. Early steel structures used riveted connections but following technological developments shop welded and site bolted connections are now common place. The introduction of high strength steels has increased the types and grades of bolt available to the designer. The range of bolts now includes ordinary strength steels bolts such as grades 4.5, 4.6 and 5.6 and high strength steel bolts such as grades 8.8, 10.9 and 12.9. Developments in automatic fabrication have seen a move away from manually produced drawings and setting out to sophisticated design software directly connected to numerically controlled machines for laser cutting, punching and drilling. The quality of welding has also improved with the introduction of continuous casting of steel and welding robots.

These changes and in particular the increase in the use of automated design and fabrication have led to an increase in quality and standardization in comparison with other structural materials. Today steel connections are economical to fabricate and erect, have a high inherent level of safety and can help the architect produce elegant and practical structures.

To take advantage of the wide range of steel products and technological developments that exist within the different European countries, the European Union created a set of common design standards for the design, fabrication and construction of steel structures. These standards are called the Eurocodes and have been developed over many years to take advantages of the different techniques available within the different member states. At the time of writing the Eurocodes are still pre-standards [ENV 1992-1-1, 1992; ENV 1993-1-1, 1992; ENV 1999-2, 1999] but within one or two years they will be converted to full Euro-norms that will eventually replace the existing National codes [prNV 1992-1-1, 2003; prEN 1993-1-2, 2003; prEN 1993-1-8: 2003]. At the inception of the Eurocode for steel structures (Eurocode 3) the importance of structural connections was recognized and a specific standard for the design of steel connections was created. This standard is part of the main steel Eurocode and is called prEN1993-1-8 - Design of Joints.

As part of the development of the early versions of Eurocode 3, background documents were prepared summarizing best practice in the design and use of bolts and welds [see Snijder 6.01 and 6.05]. Furthermore, the design models for each of these components was validated against available test data before being included in the European standard.

Traditional design methods for connections were based on a series of capacity checks and did not include methods for calculating a connection's stiffness and rotational capacity. Over the last ten years our understanding of connection behaviour has improved and methods are now available for calculating the stiffness and rotational capacity of bolted and welded connections. prEN1993-1-8 takes advantage of these developments and includes a consistent approach for calculating the stiffness, strength and rotational capacity of a limited range of bolted and welded connections. The method given in prEN1993-1-8 is called the component approach and uses the behaviour of the individual components within a connection (bolts, welds, end-plate, Column flange etc.) to build a realistic picture of a connection's load-deformation characteristic. Using this information the designer is able to predict the behaviour of simple, continuous and semi-continuous steel frames. The component approach is based on Zoetemijer's work [Zoetemijer 1983] on flush and extended end-plate connections and has been extended to include joints with angle cleats [Jaspart, 1997], composite connections [Anderson, 1998; Huber, 1999, 2001] and column bases [Wald, 1998]. In addition to beam-to-column connections, prEN1993-1-8 also includes design methods for column bases with end-plate connections, new rules for the interaction of moment and axial force at the connection, new rules for calculating the bearing capacity of slotted holes, welded connections to rectangular tubes and improved serviceability limits for pins.

Following the Northridge and Kobe earthquakes a number of research initiatives were created to improve our understanding of the behaviour of steel connections subject to seismic events. One such initiative is the Copernicus project "Reliability of moment resistant connections of steel building frames in seismic areas" (RECOs). This project is still on-going and is continuing to contribute to our knowledge of how steel frames behave under seismic loads.

Education has always been seen as an essential part of the introduction and dissemination of new methods for the design of steel connections. One of the first educational packages on connections was produced by Owens and Cheal [Owens, 1988] who prepared educational material for structural connections. This material has been extended and is now incorporated into a European educational package called the European Steel Design Educational Programme (ESDEP). This programme is used today by educational establishments throughout Europe. Other educational packages which build on the work of ESDEP are available some of which include WIVISS, a set of lectures on CD, SteelCall, a virtual steel designers office, and SSEDTA which consists of a set of basic lectures on PowerPoint for the design of steel and composite elements.

For more than twenty years the European Convention for Constructional Steelwork's Technical committee for structural connections (ECCS TC10) has supported the development and implementation of a common set of design rules for steel connections. It is therefore not surprising to find that one of this committee's priorities is to facilitate the transition of prEN1993-1-8 from a European pre-standard to a full Euro-norm. A part of this activity is the development of the necessary educational material to encourage designers throughout Europe to adopt prEN1993-1-8. Consequently, a programme called 'Continuing Education in Structural Connections (CESTRUco)' was formed under the European Commission's Leonardo initiative to collect commonly asked questions on the background, implementation and use of prEN1993-1-8 and to publish expert answers to these questions. The CESTRUco project was developed from an idea by Mr. Marc Braham (Astron, Luxembourg), Mr. Jan Stark (TU Delft, The Netherlands) and Mr. Jouko Kouhi (VTT, Finland) to provide designers with more detailed information on the background and implementation of the design methods given in prEN1993-1-8. Since the start of this project 364 questions have been collected from the countries within Europe.

The purpose of this publication is to document each of these questions together with their answers. To facilitate easy of use this document is split into the following Chapters:

- Chapter 1 - Introduction
- Chapter 2 - Bolts
- Chapter 3 - Welding
- Chapter 4 - Structural Modelling
- Chapter 5 - Simple Connections
- Chapter 6 - Moment Connections
- Chapter 7 - Column Bases
- Chapter 8 - Seismic Design
- Chapter 9 - Fire Design
- Chapter 10 - Hollow Section Connections
- Chapter 11 - Cold-Formed Connections
- Chapter 12 - Aluminium Connections
- Chapter 13 - Good and bad detailing

Each chapter starts with a brief over-view of the method use in prEN1993-1-8. This is followed by the commonly asked questions together with their answers. In due course the information contained within this document will be put on the Internet and will form part of an easily accessible Internet course for the design, fabrication and erection of structural steelwork connections.

Acknowledgements

This publication has been prepared by the following people:

Prof. C. C. Baniotopoulos (Chapters on Welding and on Aluminium),
Prof. F. S. K. Bijlaard,
Ir. R. Blok (internal review),
Mr. J. Brekelmans,
Prof. L. S. da Silva (Chapter on Fire design),
Prof. D. Dubina (Chapter on Seismic design),
Mrs. M. Eliášová,
Mr. H. G. A. Evers (Chapter on Good and bad detailing),
Mr. D. Grecea (Chapters on Hollow section connections and on Cold-formed connections),
Ir. A. M. Gresnigt (Chapter on Moment connections),
Dr. V. Janata (internal review),
Prof. B. Johansson,
Mr. T. Leino,
Mr. T. Lennon,
Mr. T. Měřínský (internal review),
Dr. D. B. Moore (editor and Chapter on Simple connections),
Mrs. A. Santiago,
Mr. R. L. Shipholt,
Dr. Z. Sokol (Chapter on Structural modelling),
Ir. C. M. Steenhuis,
Dr. M. Veljkovic (Chapter on Bolts),
Prof. F. Wald (editor and Chapter on Column bases).

The material was reviewed externally by

Prof. D. Beg,
Mr. M. Braham,
Prof. J. P. Jaspert,
Dr. G. Huber,
Mr. J. Kouhi,
Prof. F. Mazzolani,
Mr. A. Rathbone,
Prof. J. Studnička,
Dr. F. Turcic,
Dr. K. Weynand and
Mr. N. F. Yeomans.



The authors wish to dedicate this work to Mr. Martin Steenhuis, our good friend, who worked with us in the field of structural connections for many years, launched this project, and who tragically died in the summer of 2001.

2 BOLTS

Introduction

Connections are used to transfer the forces from one member to another. Although both welded and bolted connections can be used in steel structures, bolted connections are commonly used because of the ease of fabrication, buildability and ability to accommodate minor site adjustments. The different types of bolted connections include cover plates, end plates and cleats and in each of these connections the bolts are used to mechanically fasten the steel elements.

The performance of a bolted connection is complicated and both the stress distribution in the connection and the forces in the bolts are dependent on the stiffness of the bolts, and the connecting steel elements (end plates, cleats, etc.). Consequently, an exact theoretical analysis is not possible.

The design of a bolted connection is semi-empirical, namely based on past experience of good performance, custom and practice, but always validated with a statistical evaluation of test results. An example of a semi-empirical rule is given in Clause 3.6.1(5) of prEN1993-1-8: 2003 which states that the shear resistance of M12 and M14 bolts should be calculated by multiplying the expression for calculation the shear capacity by a factor 0,85 in cases where they are used in holes with 2 mm clearance. When they are used in 1 mm clearance holes, this reduction with the 0,85 factor is not necessary. For bolts M16 to M24, this reduction is also not necessary, when used in 2 mm clearance holes. This also holds for bolts M27 and larger, when used in 3 mm clearance holes.

Basic characteristics of bolts

The bolt grades shown in Table 2.1 are commonly used in steel connections. All of these bolt grades are generally used in connections subject to static forces and moments. For connections subject to fatigue friction grip connections with high strength bolts such as grades 8.8 and 10.9 are to be used because of their high fatigue strength and limited deformation characteristics. The basic mechanical properties for 4.6, 5.6, 6.8, 8.8, and 10.9 grade bolts are shown in Table 2.1.

Table 2.1 Basic mechanical properties of structural bolts

Bolt grade	4.6	5.6	6.8	8.8	10.9
f_{yb} , MPa	240	300	480	640	900
f_{ub} , MPa	400	500	600	800	1000
Material and treatment	low or medium carbon steel, fully or partially annealed			medium carbon alloy steel, quenched and tempered	

The weakest section of any bolt is its threaded portion. The strength of the bolt is usually computed by using the “tensile stress area“ (also called the “resistant area”) defined by the average diameter of the core of the shank d_n and the “average” diameter, d_m , as pictured in Figure 2.1.

$$d_{res} = \frac{d_n + d_m}{2} \quad (2.1)$$

Bolt sizes are defined in terms of their nominal diameter, length under the head and thread length.

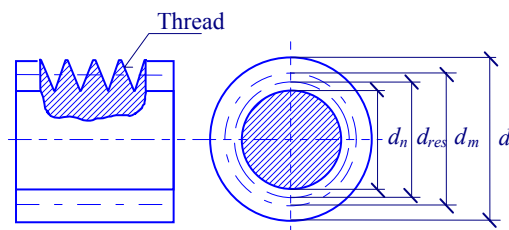

Figure 2.1 Cross-section of the bolt and the resistant area [Ballio, Mazzolani, 1983]

Bolt performance in the connection

The ultimate strength of bolted connections is evaluated assuming simplifications on the redistribution of internal forces as suggested by experimental evidence. Considering the load transfer across the joint, bolts may behave as either:

- 1) bearing-type bolts. This means that the plates joined are restricted from moving primarily by the bolt shank;
- 2) pre-loaded friction-grip connection made with high-strength bolts. This means that the plates are clamped together by the tension induced in the bolts by tightening them; or
- 3) bolts in tension.

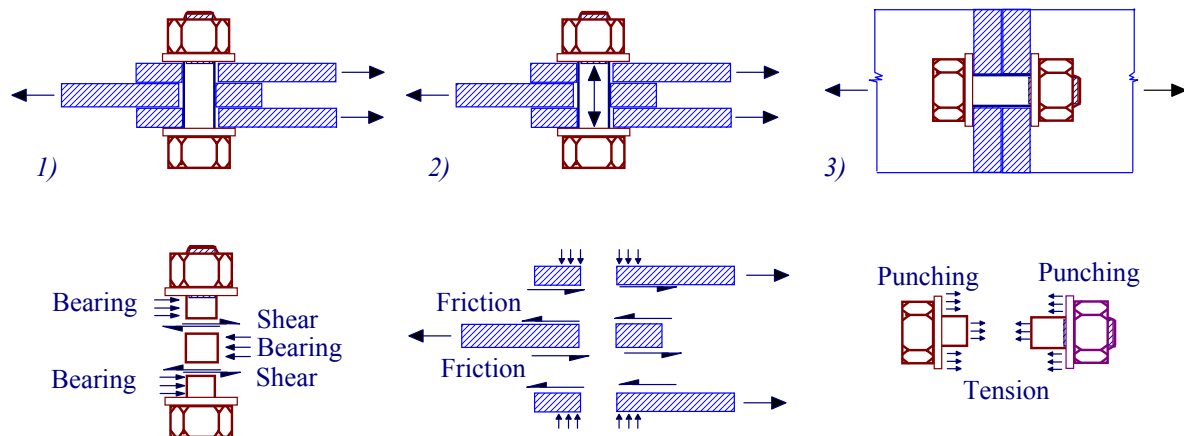

Figure 2.2 Force components in the bearing bolts and pre-loaded bolts, according to [Trahair et al, 2001]

Internal forces (shear, bearing, and tension) may be transferred by bearing bolts and by friction between plates clamped together in the case of a preloaded friction grip joint. These forces are shown in Figure 2.2 for bearing bolts and preloaded bolts, respectively. Furthermore, there are many types of connections where bolts are exposed to combined shear and tension.

Bearing type bolts

Bolts predominantly loaded by static loads should be “snug-tight” (spanner-tight). The tightness is attained by a person using an ordinary spanner. The clamping is sufficient to produce a small friction force between the connected parts and is enough to transfer a small load with no slip. Increasing the applied load overcomes this friction and permanent slip occurs due to clearance between bolt and hole. The slipping stops when the shank of the bolt comes into contact with the plate. When further load is applied, there is an elastic response until plastic deformation starts either in the shank of the bolt or in the connected plate. The plastic deformation may start simultaneously in the bolt and in the plate. The connection will eventually fail in one of following modes:

- Shear of the bolt
- Bearing failure
- Block tearing

The design values for shear resistance and bearing resistance are given in Table 3.4 and for the block tearing the method is given in Clause 3.10.2 of prEN1993-1-8: 2003. The resistance for block tearing is actually based on two possible failure mechanisms: either shear yielding combined with tension rupture or shear rupture combined with tension yielding, according to [Aalberg, Larsen, 2000]. The failure type depends on the dimensions of the connection and the relative strength of the bolt materials and that of the connected parts.

Slip-resistant connections

In the case of reversible loads, high-strength bolts need to be tightened to, at least, 70% of their ultimate tensile strength [Nair et al, 1974]. By using this method, the load is transferred across

the joint by friction between the connected parts rather than by shear of the fasteners [Kitipornchai et al, 1994]. Three categories of bolted connections B, C and E. These are specified in Clause 3.4.1 of prEN1993-1-8: 2003. Their resistance is a function of the slip factor (slip coefficient) of the faying surfaces, μ , and the clamping force, $F_{p,C}$, provided by the high-strength bolts. Clause 3.5 of prEN1993-1-8: 2003 gives a number of classes of friction surfaces where μ varies from 0,2 to 0,5. However, other surface conditions may be used provide the coefficient of friction is obtained by testing. A hardened washer has to be used under the element which is rotated during the tightening for 8.8 bolts (under the bolt head or the nut whichever is to be rotated) and under both the bolt head and the nut in the case of 10.9 bolts, see Clause 8.5(4) [ENV 1090-1].

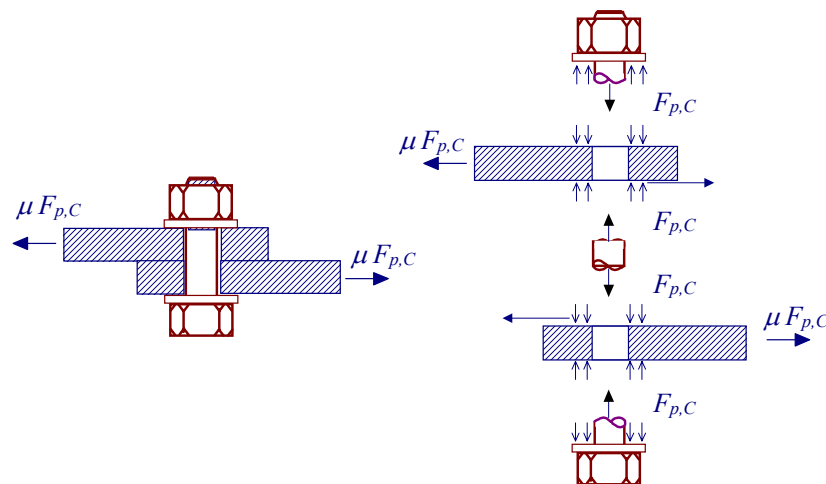

Figure 2.3 High-strength bolt in a friction type connection, according to [Kuzmanovic, Willems, 1983]

The tensile force introduced into a high-strength bolt during installation may be controlled using one of the following methods:

- 1) Torque control method using a torque wrench (based on controlling the applied torque)
- 2) Turn-of-the-nut method (a certain angle of rotation is applied beyond the “snug-tight” condition which depends on a total thickness of all packs and washers)
- 3) Direct-tension indicator method
- 4) Combined method (combination of the first two methods)

Q&A 2.1 Loss of bolt pre-load

Recent tests in France have indicated that considerable reductions in bolt pre-load of between 25% to 45% can occur over a 2 to 3 month period when standard protective paint coatings are used. How is this effect incorporated in the design of connection with pre-loaded bolts?

Standard protection paint coatings should not be used with slip-resistant connections as they reduce the coefficient of friction between the contact surfaces. This, in turn, will significantly reduce the capacity of the connection. However, special friction paints can be used.

Q&A 2.2 Bearing of slip resistant connections

Why are Category C slip resistant connections checked for bearing at the ultimate load, see Clause 3.4.1(4), when slip is not allowed in the connection at the ultimate limit state?

In this type of connection there is a possibility that some of the bolts may bear against the connection plates as a result of the set-up during erection (i.e. the bolts are not in the centre of the bolt holes but are in contact with the plate at the edge of the bolt hole). Therefore, to ensure complete safety, the bolts are also checked for bearing failure at the ultimate load.

Q&A 2.3 Shear resistance of pre-loaded bolts carrying a tension force

According to Clause 3.9.2 the pre-loading force $F_{p,Cd}$ is not reduced by the whole tension force F_t applied externally when tension and shear for friction bolts are combined. What is the reason for this?

Preloading the bolt deforms both the plates and the bolt. This behaviour may be simplified as shown in Figure 2.4 [Fisher, Struik, 1987]. The elongation of the bolt δ_b is adequate to bolt preload F_p and the plate shortening δ_p . By applying an external tensile force F_t , the total bolt force will be F_b under an elongation of $\delta_{b,ext}$, see [Kulak et al, 1974].

The external tensile force will be partially absorbed as new, additional forces in the bolt ΔF_b , and partially absorbed by a reduction in the force that the joint originally exerted on the bolt ΔF_j . The increase of bolt force is ΔF_b and the decrease of clamping force is ΔF_p with the deformation of joint $\delta_{p,ext}$. The dashed line shows the influence of plate bending flexibility under prying. By applying the tensile force to the joint a part of the preloaded force remains, due to the deformation of the plates see Figure 2.4. The stiffness ratio between the tensile bolt and the compression plates (of about 1 to 4) results in a contact force remaining between the plates, at least equal to

$$F_c = F_p - 0,8 F_t, \quad (2.2)$$

when the force F_t is applied under the usual conditions. The validity of the 0,8 factor is based on an assumed cylinder in compression with a fixed area, whereas finite element studies indicate a barrel of compression such that the factor should be a function of the thickness, and possibly of the bolt grade, steel grade and number of plies.

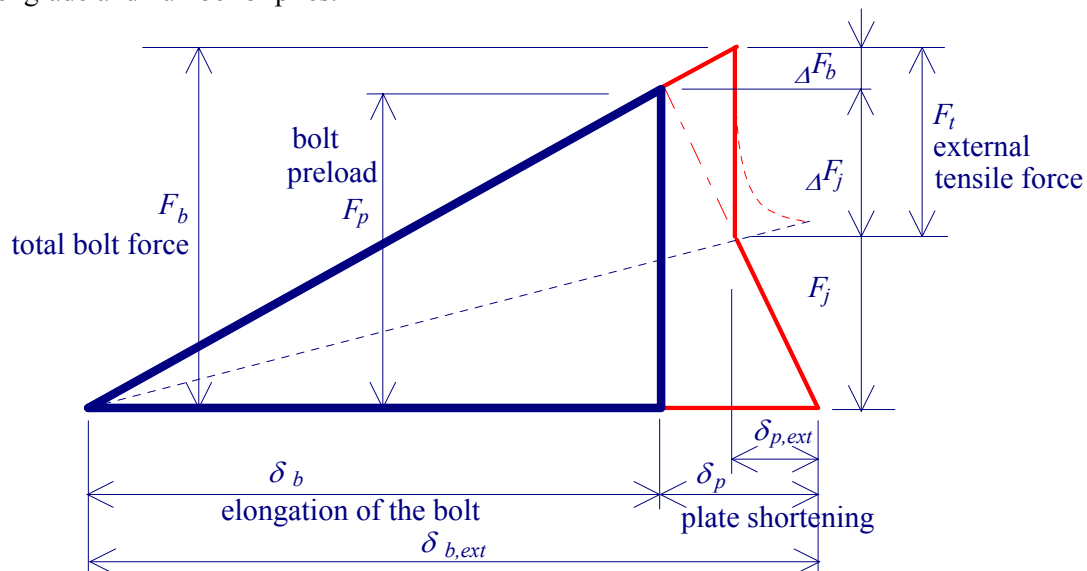

Figure 2.4 Diagram of internal forces in joint with preloaded bolt loaded by tensile forces, according to [Bickford, 1995]

Q&A 2.4 Maximum bolt end and edge distances

What is the background to the maximum spacing p_1 and p_2 of 14 t or 200 mm given in Table 3.3, prEN1993-1-8?

The limits for p_1 and p_2 are given independent of the weather or other corrosive influences on the joint. Appearance of the structural element local buckling and behaviour of a long joint have to be taken into account. Local buckling resistance between the fasteners should be calculated according to EN 1993-1-8, see requirements in Table 3.3 note 2. If the joint is made very long the strains in the base material will lead to an uneven distribution of forces. This effect is taken into account by the rules in 3.8 where the shear resistance may be reduced depend on the joint length.

Note that there are no maximum limits specified for the edge distances e_1 and e_2 for a joint not exposed to corrosive influences.

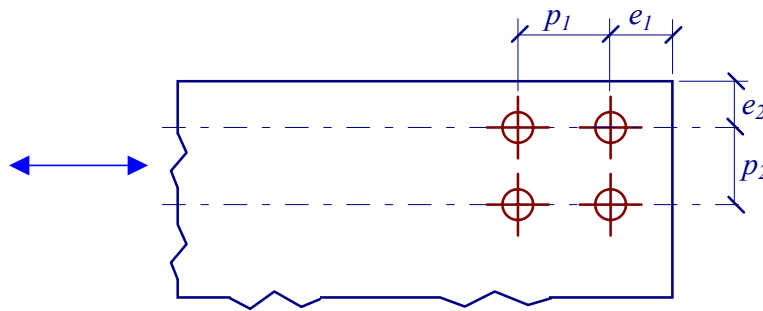

Figure 2.5 Symbols for spacing of fasteners

Q&A 2.5 Deformation criteria for bolt bearing resistance

Bearing design is more concerned with avoiding excessive hole deformations than with avoiding actual failure of the connection. Comparison of the design formula for bearing with tests confirms this point. Could you give the background to the deformation criteria that has been adopted in the derivation of the formula?

The traditional background of most codes indicates the resistance $F_{exp;1,5}$ is limited to a deformation of $1,5\text{ mm}$, see [Owens et al, 1999]. The resistance for the structural members obtained from the tests to failure $F_{exp;fy/fum}$ is evaluated by reducing the resistance from structural material strength f_{um} to the characteristic yield strength f_y , see [Bijlaard et al, 1989] and [Bijlaard et al, 1988]. The procedure is used in form $F_{exp;fy/fum} = 0,9 F_{exp;ult;fy/fum}$ if a brittle rupture occurs [Snijder et al, 1988a]. The conventional (elastic) limit of resistance $F_{exp;conv}$ defines the resistance as the intersection of a straight line with the initial stiffness and of a straight line having the slope equal to stiffness divided by ten, which is drawn as a tangent to the non-linear part of the curve, see Figure 2.6, test [Piraprez, 2000]. The conventional resistance depends more on the joint stiffness than on the failure type. Annex D of prEN 1990: 2001 was used for cover plate tests with slotted holes to validate the model of resistance, see [Wald et al, 2002b].

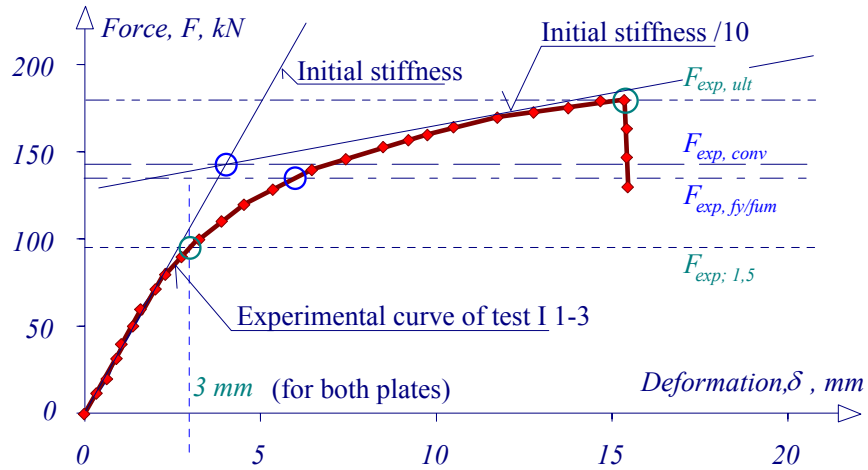

Figure 2.6 Limits of the resistance of joint; deflection limit $F_{exp,1,5}$; ultimate limit $F_{exp,ult}$; conventional limit $F_{exp,conv}$; reduced limit by steel yield ratio $F_{exp,fy/fum}$ [Piraprez, 2000]

Q&A 2.6 End and edge bolt distances

prEN 1993-1-8: 2003 does not contain edge/end distant rules when the edges and row of fasteners are neither in the direction of the force nor perpendicular to the force, see Figure 2.7. How should these distances be determined?

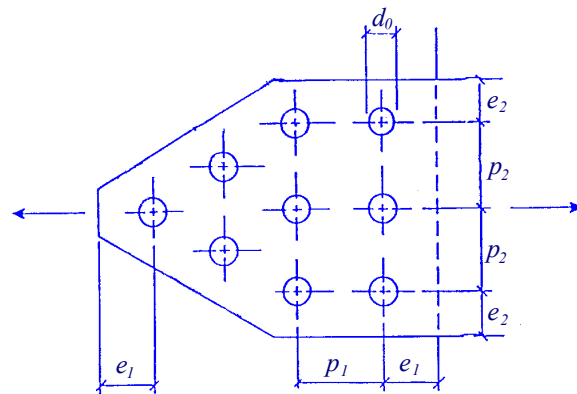

Figure 2.7 End and edge bolt distances

The edge distances e_1 and e_2 and the distances between rows of fasteners p_1 and p_2 may be determined using the semi-axis in the ellipse with the plate edge as tangent, and the semi-axis in the ellipse with its centre in one hole and through the other hole, respectively. This is illustrated in Figure 2.8.

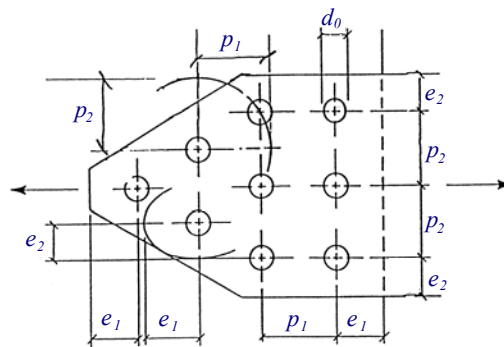

Figure 2.8 Distances to the end and edge

Q&A 2.7 Bearing resistance of bolt group

Can the bearing resistance for individual bolts be added together or not? Some clarification is needed. See Figure 2.9 and example below:

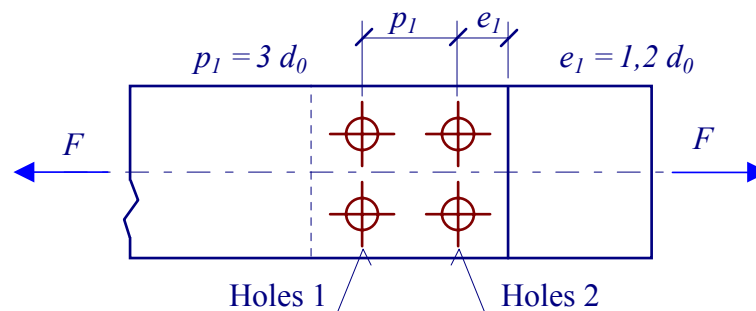

Figure 2.9 Non-symmetrical connection

For the holes 2:

$$\alpha = \frac{e_1}{3 d_0} = \frac{1,2 d_0}{3 d_0} = 0,4$$

For the holes 1:

$$\alpha = \frac{p_1}{3 d_0} - 0,25 = \frac{3 d_0}{3 d_0} - 0,25 = 1 - 0,25 = 0,75 .$$

Method 1

The total bearing resistance is based on direct summarising

$$F_{b,Rd} = \left(\sum \alpha \right) \frac{2,5 d t f_u}{\gamma_{Mb}} = (2 \cdot 0,4 + 2 \cdot 0,75) \cdot \frac{2,5 d t f_u}{\gamma_{Mb}} = 2,3 \cdot \frac{2,5 d t f_u}{\gamma_{Mb}} .$$

Method 2

The total bearing resistance is based on smallest of the individual resistances

$$F_{b,Rd} = \left(\sum \alpha \right) \frac{2,5 d t f_u}{\gamma_{Mb}} = (2 \cdot 0,4 + 2 \cdot 0,40) \cdot \frac{2,5 d t f_u}{\gamma_{Mb}} = 1,6 \cdot \frac{2,5 d t f_u}{\gamma_{Mb}} .$$

If method 1 is used then the deformation in holes 2 can be high at the serviceability limit state if all loads are permanent loads.

It is good engineering practice to create a symmetrical connection to avoid an unnecessary plastic redistribution of internal forces. The summation of the resistances of the individual bolts is not a safety but a serviceability issue. If there is a need to limit the deformations then a separate serviceability limit state check should be carried out. Recommendations are given in Clause 3.7, prEN 1993-1-8, on how to calculate the resistance of a group of bolts. For unsymmetrical connections strain hardening of the plates may be taken into account by ensuring $F_{v,Rd} \geq 1,2 F_{b,Rd}$.

Q&A 2.8 Bearing resistance in slotted holes

Note 1 to Table 3.4 prEN 1993-1-8 states that the reduction in bearing resistance for the case of slotted holes is 60% of that used for a normal size clearance hole when the force is perpendicular to the long direction of the slot. Is there any experimental evidence available to support this?

Nominal clearances for bolts in slotted holes are given in ENV 1090-1, Clause 8. The reduction factor for resistance applied in prEN 1993-1-8 is based on the latest experiments [Wald et al, 2002a,b], [Piraprez, 2000], [Tizani, 1999]. A lower design resistance is required primarily because of the lower stiffness.

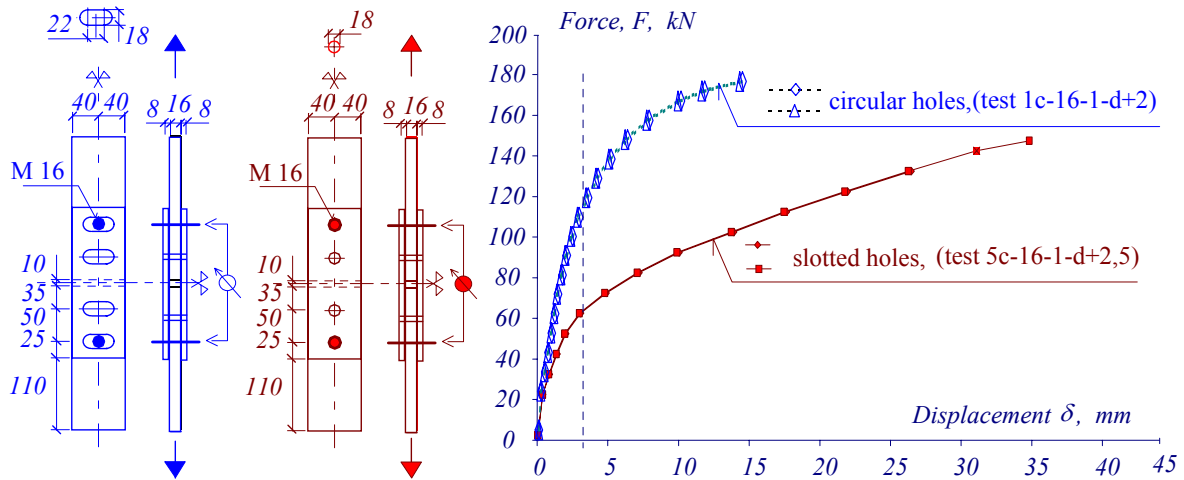
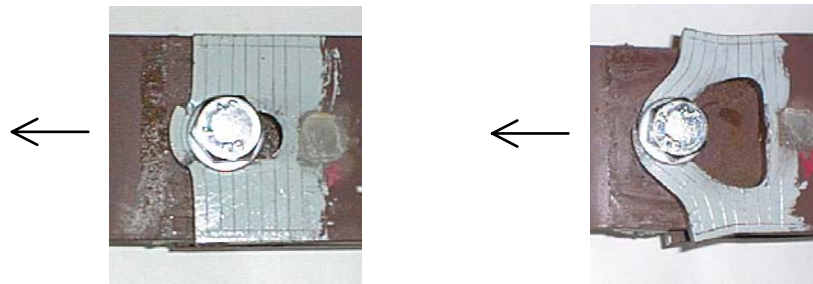

Figure 2.10 Comparison of typical force - displacement diagrams of test with slotted holes to circular holes, [Wald et al, 2002a]

It is clear from Figure 2.10 that bolted connection with slotted holes perpendicular to the applied forces exhibit lower stiffness and higher deformation capacity compare to connections with circular holes.



a) bearing failure in shear b) bearing failure in bending
Figure 2.11 Bearing failure of the slotted plate [Wald et al, 2002b]

The bearing resistance is predicted using the following simple model

$$F_{b,Rd} = \beta_R \frac{2,5 \alpha f_u d t}{\gamma_{Mb}}, \quad (2.3)$$

where α is the smallest of

$$\frac{e_1}{3 d_o} ; \frac{p_1}{3 d_o} - \frac{l}{4} ; \frac{f_{ub}}{f_u} \text{ or } 1,0. \quad (2.4)$$

The reduction factor β_R due to the slot was established using a standard procedure for determining the partial safety factors from the test results, see [Wald et al, 2002b]. Influence of the slot length in the plate failure is shown in Figure 2.12 where the results of 70 tests are shown.

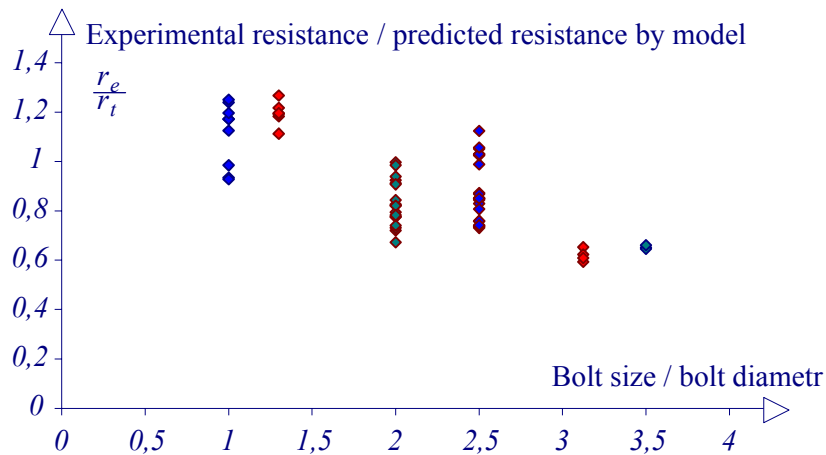

Figure 2.12 Experimental results versus resistance prediction by the design model for evaluation of β_R

Q&A 2.9 Design method for fitted bolts

Could you provide a design method for fitted bolts? Give clarification and guidance covering the following: tolerance on the hole diameters, bearing resistance, and assembly. Any limitations assumed on the presence of threads in the bearing areas and shear plane.

Usually the tolerances are h12/H13 [EN ISO 898-1] which leads to a clearance of approximately 0,3 mm. Bearing resistance can be taken as the same as that for bolts in clearance holes. Assembly of the joint follows the normal procedure if the holes are prepared in the work shop. An alternative is to do the final reaming of the holes on site in connection with the assembly. Threads are not allowed in the bearing area.

Q&A 2.10 Combined shear and tension

According to Clause 6.5.5(5) of prEN 1993-1-8, a bolt loaded by a tension force equal to the design tension resistance $F_{t,Rd}$ can still take a shear force of $F_{v,Sd} = 0,286 F_{v,Rd}$. What is the technical background to this formula? A more logical approach is given by the following formula

$$\frac{F_{v,Sd}}{F_{v,Rd}} + \frac{F_{t,Sd}}{F_{t,Rd}} \leq 1. \quad (2.5)$$

Experimental observations have shown that bolts subjected to full shear have a significant tension capacity. The tensile resistance is limited by fracture of the threaded part of the bolt but the interaction between shear and tension is assumed to take place in the shank. An alternative interaction formula is one based on the terms squared with the tensile resistance of the bolt shank in the denominator as it is found in [Owens, Cheal, 1989]. According to Figure 2.13, variation in the ratio of shear strength to tension strength is 0,63-0,68 if the shear plane cuts the threaded portion and 0,75-0,89 if the shear plane is in the bolt shank.

If the shear plane cuts the bolt shank then the following two failure modes may occur:

- combine shear and tension on the shear plane, or alternatively
- the bolt fails primarily in tension in the threaded portion.

It is observed in experiments that the shear strength of the bolts increases with the increase in the grip length. This can be explained by the greater bending that develops in a long bolt as compared to a short grip bolt. The interaction equation used in prEN 1993-1-8: 2003 is given below.

$$\frac{F_{v,Sd}}{F_{v,Rd}} + \frac{F_{t,Sd}}{1,4 F_{t,Rd}} \leq 1 \quad (2.6)$$

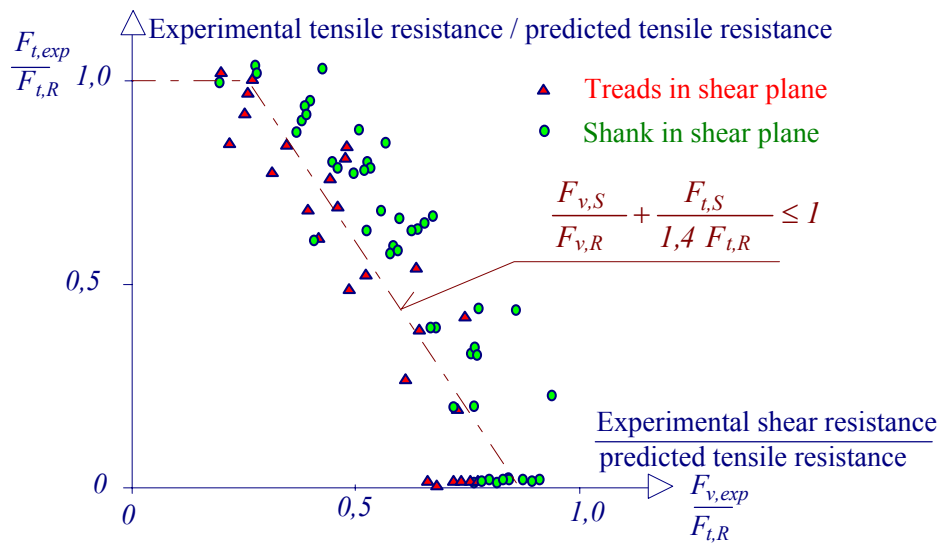

Figure 2.13 Interaction curves according to [Owens, Cheal, 1989] with requirements given in standard prEN1993-1-8

Q&A 2.11 Resistance of connections using high-strength steel

Is it possible to design connection in high-strength steel, with nominal yield strengths of 640 MPa using requirements given in prEN1993-1-8: 2003?

prEN 1993-1-8: 2003 has been validated for steel grades up to S460 and therefore the method given in the standard should not be used for higher grade steels.

An experimental study performed on double shear plane bolted connection was presented in [Kouhi, Kortessmaa, 1990]. Plates were tested nominally yield strength of 640 MPa and ultimate strength of 700 MPa. Bolts made of 10.9 grade were used and the following failure modes were obtained in the tests: bearing resistance, block shear failure and the net section failure on 18 tests, 6, test and 6 tests, respectively.

Test results are compared with the design models given in prEN1993-1-8: 2003 and all the results are found to be on a safe side, see Figure 2.14.

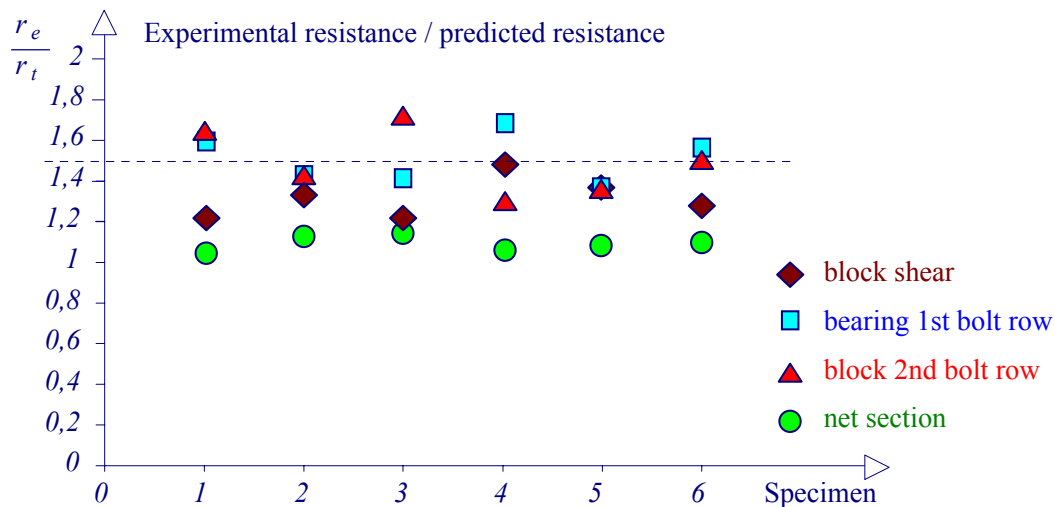

Figure 2.14 Resistance of the bolted connection of tests studied in [Kouhi, Kortessmaa, 1990].

Note:

- Formulae for bearing resistance and net section resistance used in the original paper give same results as prEN1993-1-8: 2003.
- Formula for block shear resistance in prEN1993-1-8: 2003 is conservative compared to the original publication.
- Bearing resistance of the whole connection calculated by summarizing the bearing resistance of each individual bolt is shown in Figure 2.14. The deformations measured in the tests at the ultimate limit state were similar to the magnitude of the bolt diameter. Bearing resistance obtained using the lowest individual bolt resistance are on the safe side.
- Two test groups were performed to study bearing resistance. One group of six specimens had one row of bolts and the second group had two rows of bolts, indicated in Figure 2.14 as bearing-1r and bearing-2r, respectively.
- Plates with thickness of 3 mm, 4 mm, 6 mm and 8 mm were used in the tests. Measured yield strengths in range from 604 MPa to 660 MPa for plate thickness 6 mm and 4 mm respectively. The ultimate strength was in the range 711 MPa to 759 MPa for plate thicknesses 6 mm and 4 mm, respectively. The measured properties were obtained as the mean values of three specimens.

3 WELDING

The majority of welded connections are produced in the fabricator shop. During the design the ductility of the weld needs to be guaranteed. This is resolved by a set of design rules. For structural steel connections metal arc welding is used on all but a few special cases such as stud welding. When using this approach the weld metal should be compatible with the parent metal in terms of its mechanical properties. The material thickness should be at least 4 mm (special rules need to be applied for welding thin walled elements). Welds can be classified as fillet welds, slot welds, butt welds, plug welds and flare groove welds. prEN 1993-1-8 provides requirements for the effective length of a fillet weld with a throat thickness a , see Figure 3.1.

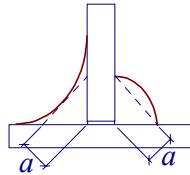

Figure 3.1 Definition of throat thickness a

In the design procedure the internal force on the fillet weld is resolved into components parallel and transverse to the critical plane of the weld throat, see Figure 3.2. A uniform stress distribution is assumed on the critical throat section of the weld, leading to the following normal stresses and shear stresses:

- σ_{\perp} the normal stress perpendicular to the critical plane of the throat,
- $\sigma_{//}$ the normal stress parallel to the axis of the weld, it should be neglected when calculating the design resistance of a fillet weld,
- τ_{\perp} the shear stress (in the critical plane of the throat) perpendicular to the weld axis,
- $\tau_{//}$ the shear stress (in the critical plane of the throat) parallel to the weld axis.

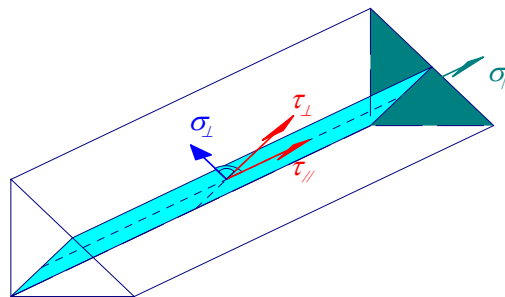

Figure 3.2 Stress in critical plane of fillet weld

The resistance of the fillet weld will be sufficient if the following two conditions are satisfied:

$$\sqrt{\sigma_{\perp}^2 + 3(\tau_{\perp} + \tau_{//})^2} \leq \frac{f_u}{\beta_w \gamma_{Mw}} \quad (3.1)$$

and

$$\sigma_{\perp} \leq \frac{f_u}{\gamma_{Mw}} \quad (3.2)$$

The correlation factor β_w is summarised in Table 3.1.

prEN 1993-1-8 includes a simplified procedure for calculating the design shear resistance of the fillet weld per unit length independent of the direction of loading, see Figure 3.3,

$$f_{vw,d} = \frac{f_u}{\sqrt{3} \beta_w \gamma_{Mw}} \quad (3.3)$$

and the resistance of the weld per unit length is

$$F_{w,Rd} = a f_{vw,d} \quad (3.4)$$

Table 3.1 Correlation factor for weld resistance

Standard and steel grade			Correlation factor β_w
EN 10025	EN 10210	EN 10219	
S 235 S 235 W	S 235 H	S 235 H	0,8
S 275 S 275 N/NL S 275 M/ML	S 275 H S 275 NH/NLH	S 275 H S 275 NH/NLH S 275 MH/MLH	0,85
S 355 S 355 N/NL S 355 M/ML S 355 W	S 355 H S 355 NH/NLH	S 355 H S 355 NH/NLH S 355 MH/MLH	0,9
S 420 N/NL S 420 M/ML		S 420 MH/MLH	1,0
S 460 N/NL S 460 M/ML S 460 Q/QL/QL1	S 460 NH/NLH	S 460 NH/NLH S 460 MH/MLH	1,0

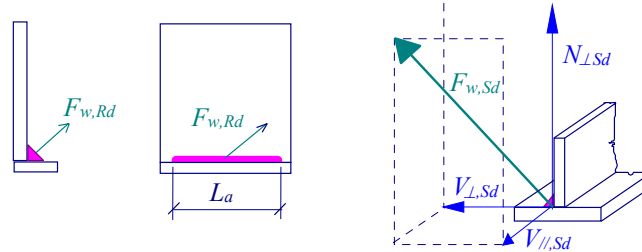

Figure 3.3 Design of fillet weld independent of the direction of loading

When very long welds are exposed to a force in the direction of the weld the stresses in the middle of the weld may be lower compare to the corners, see Figure 3.4a. This results from the deformations of the connected plate. If the plates are adequate the stresses in the welds are uniform, see Figure 3.4b. This overloading may result in failure of the ends of the welded connection (zip effect). Resistance of welds longer than $150 a$ should be reduced by the factor β_{Lw} , see Figure 3.4c,

$$\beta_{Lw} = 1,2 - 0,2 \left(\frac{L}{150 a} \right) \quad (3.5)$$



a) non-uniform distribution of internal stresses

b) uniform distribution of internal stresses

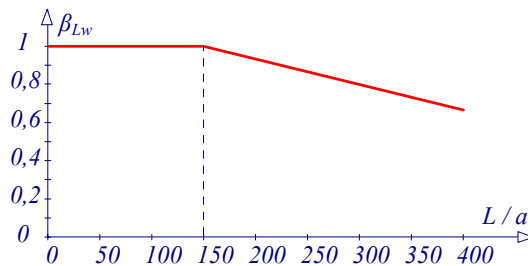

c) reduction factor β_{Lw}

Figure 3.4 Long weld

As far as butt welds are concerned, full penetration welds have a design resistance that is equal to the design resistance of the weaker of the parts joined. The resistance of a partial penetration butt weld shall be determined in a similar way to that for deep penetration fillet welds. The depth of the penetration should be obtained by tests.

Joint details causing through-thickness stresses originating from welding carried out under conditions of restraint shall be avoided whenever possible, to reduce the possibility of lamellar tearing. Where such details are unavoidable appropriate measures must be taken. The distribution of forces in a welded connection may be calculated by using either an elastic or a plastic method.

Q&A 3.1 Connecting Two Angles to Gusset Plate

Should the eccentricity between the welds and the centre of the angle be taken into account?

In general the forces and moments due to all eccentricities should be taken into account when calculating the stresses in the weld. In the case of equal angles it is common European practice to neglect the eccentricity in the design of welds.

If the unequal angles are connected to a fin plate the eccentricity is taken into account by member design as well as by weld design. The following example shows how the forces in the weld can be calculated.

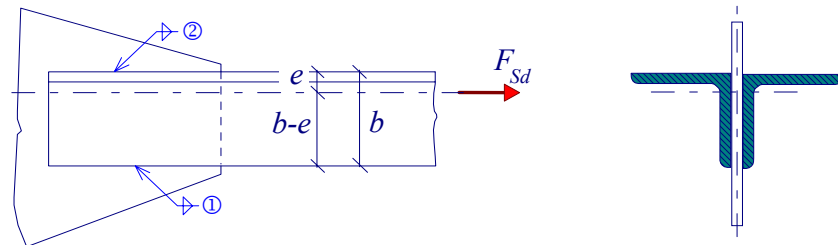

Figure 3.5 Angles connected to a gusset plate

The weld on the lower side, marked as weld ①, is loaded by the force F_1 equal to

$$F_1 = \frac{F_{Sd}}{2} \frac{e}{b}, \quad (3.6)$$

which causes shear stresses parallel to the axis of the weld $\tau_{//}$

$$\tau_{1, //} \leq \frac{f_u}{\sqrt{3} \beta_w \gamma_{Mw}} \quad (3.7)$$

This is the only stress in this weld. The resistance of the weld can be checked using formula (3.3), which can be simplified to

$$\tau_{1, //} \leq \frac{f_u}{\sqrt{3} \beta_w \gamma_{Mw}}. \quad (3.8)$$

The force F_2 on the upper weld, (weld ②), is equal to

$$F_2 = \frac{F_{Sd}}{2} \frac{(b-e)}{b} \quad (3.9)$$

and the shear stress $\tau_{//}$

$$\tau_{2, //} = \frac{F_2}{a_2 L_2}. \quad (3.10)$$

Q&A 3.2 Effective Width of Welded Beam-to-Column Connection

When designing welded beam to column connection, an effective width is used to calculate the resistance of the column flange in bending. Is it possible to design the welds connecting the beam flange to column flange using the width b_{eff} , if the effective width is smaller than width of the beam flange?

According to prEN1993-1-8 Clause 6.2.4.4 for unstiffened column flanges in bending, the tensile design resistance is calculated using the following formula:

$$F_{t,fc,Rd} = \left(t_{wc} + 2s + 7k t_{fc} \right) \frac{t_{fb} f_{yb}}{\gamma_{M0}} \quad (3.11)$$

where

$$k = \min \left(\frac{f_{yc} t_{fc}}{f_{yb} t_{fb}}; 1 \right) \quad (3.12)$$

and t_{wc} is thickness of column web, t_{fc} thickness of column flange, t_{fb} thickness of beam flange and s is equal to fillet radius r_c for hot rolled column sections, see Figure 3.6.

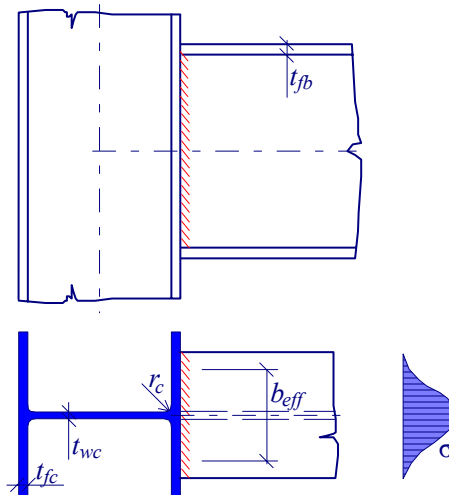

Figure 3.6 Effective width of beam flange of welded joint and stress in the connected flange

According to prEN 1993-1-8 Chapter 4.10 the effective width b_{eff} of a fillet weld connecting the beam flange is

$$b_{eff} = t_{wc} + 2s + 7t_{fc} \quad (3.13)$$

but it is limited to

$$b_{eff} = t_{wc} + 2s + 7 \left(\frac{t_{fc}^2}{t_{fb}} \right) \left(\frac{f_{yc}}{f_{yb}} \right) \quad (3.14)$$

Substituting equation 3.12 into 3.11 gives the same effective width for calculating the resistance of the beam flange in tension as that used for the fillet weld.

Q&A 3.3 Throat Thickness of a Fillet Weld used in a Hollow Section Joints

Do the rules for the throat thickness of a weld given in prEN 1993-1-8 guarantee, that there is enough deformation capacity in the welds such that the welds are not the weakest part of the whole joint?

The expressions given in prEN 1993-1-8 relate the throat thickness of the fillet weld a to the minimum thickness t of the welded hollow section members, see Table 3.2. If the previous relations are fulfilled, the fundamental criterion of welding between hollow sections is satisfied. Then, the design resistance of the weld per length of the perimeter of a diagonal member is not less than the design resistance of the cross section of this member per length of the perimeter. This criterion ensures that there is enough deformation capacity in the welds, which allows the redistribution of the bending moments.

Table 3.2 Minimum throat thickness for fillet welds of hollow section joints

Steel grades according to EN 10025	
S 235	$a/t \geq 0,84 \alpha$
S 275	$a/t \geq 0,87 \alpha$
S 355	$a/t \geq 1,01 \alpha$
Steel grades according to EN 10113	
S 275	$a/t \geq 0,91 \alpha$
S 355	$a/t \geq 1,05 \alpha$

When $\gamma_{Mj} = 1,10$ and $\gamma_{Mw} = 1,25$, then $\alpha = 1,0$; otherwise $\alpha = 1,10 \gamma_{Mw} / (1,25 \gamma_{Mj})$

Q&A 3.4 Modelling the Resistance of a Fillet Weld

prEN 1993-1-8 gives two methods for the design of fillet welds, the exact method and the simplified one. What are the differences between these two methods?

There is no difference in the case of a connection loaded by a force parallel to the weld, see Figure 3.7.

$$f_{w,Rd} = \frac{f_u}{\sqrt{3} \beta_w \gamma_{Mw}} \quad (3.15)$$

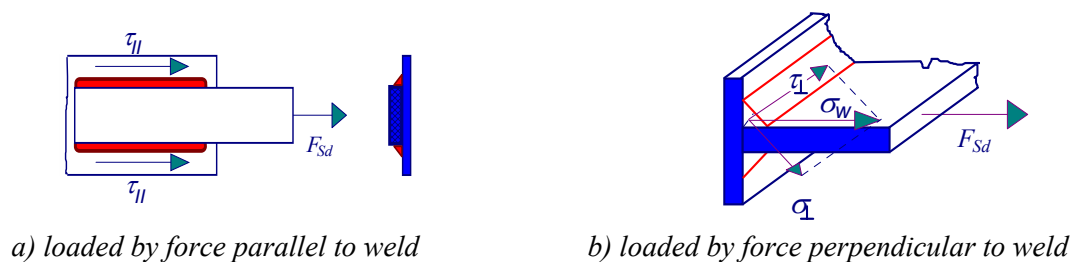

Figure 3.7 Fillet weld

For a weld loaded perpendicular to its length the differences between the two models are significant. The stresses may be calculated as

$$\sigma_{\perp} = \tau_{\perp} = \frac{\sigma_w}{\sqrt{2}} \quad \text{and} \quad \tau_{\parallel} = 0 \quad (3.16)$$

From the plane model we obtain

$$\sqrt{\left(\frac{\sigma_w}{\sqrt{2}}\right)^2 + 3\left(\frac{\sigma_w}{\sqrt{2}}\right)^2} \leq \frac{f_u}{\beta_w \gamma_{Mw}} \quad \text{and} \quad \sigma_w \leq \frac{f_u}{\beta_w \gamma_{Mw} \sqrt{2}} = f_{w.end.Rd} . \quad (3.17)$$

The difference will be

$$f_{w.end.Rd} / f_{w.Rd} = \sqrt{3} / \sqrt{2} = 1,22 . \quad (3.18)$$

Q&A 3.5 Design of Partially Penetrated Butt Weld

What procedure is recommended for the design of partially penetrated butt welds?

Partially penetrated butt welds may be designed as fillet weld with an effective width of $a = a_{nom} - 2 \text{ mm}$, see Figure 3.8a.

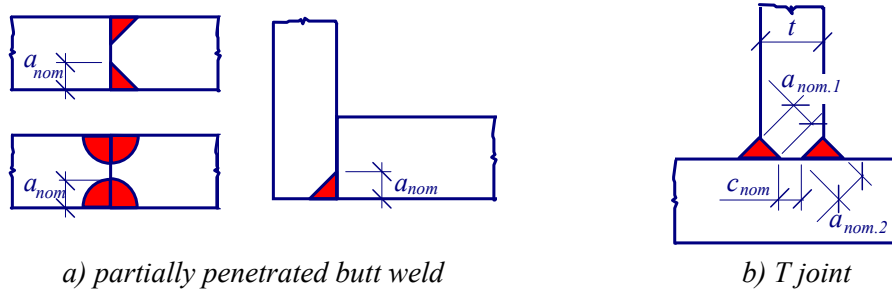

a) partially penetrated butt weld

b) T joint

Figure 3.8 Effective width

For T joints full penetration is assumed in the case of

$$a_{nom.1} + a_{nom.2} \geq t$$

$$c_{nom} \leq \frac{t}{5} \quad (3.19)$$

$$c_{nom} \leq 3 \text{ mm} .$$

In the case of partial penetration in the T joint, see Figure 3.8b, the weld is designed as a fillet weld with an effective width

$$a_{nom.1} + a_{nom.2} < t$$

$$a_1 = a_{nom.1} - 2 \text{ mm} \quad (3.20)$$

$$a_2 = a_{nom.2} - 2 \text{ mm} .$$

Q&A 3.6 Weld Design for Full Resistance of Connecting Members

What are the recommendations for the design of a fillet welds in the case of a connection with full member resistance?

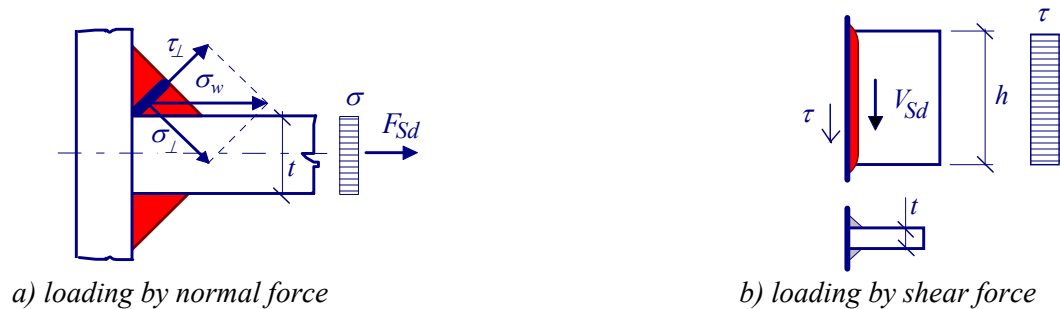

Figure 3.9 Fillet weld effective thickness

In the above case, see Figure 3.9, the weld may be designed to resist the applied forces. The weld thickness may be calculated as

$$a > 0,7 \frac{\sigma t}{f_u / \gamma_{Mw}}, \quad (3.21)$$

where $\sigma = F_{Sd} / (t h)$, and F_{Sd} is the acting design force, f_u is plate design strength, t is the thickness of connecting plate, b is width of connecting plate. If an elastic global analysis is used the weld need to carry the full capacity of a plate the thickness, assuming S235 steel ($f_y = 235 \text{ MPa}$; $f_u = 360 \text{ MPa}$), is given by the following expressions

$$a > 0,7 \frac{(f_y / \gamma_{M0}) t}{f_u / \gamma_{Mw}} = 0,7 \frac{(235 / 1,10) t}{360 / 1,25} = 0,52 t \approx 0,5 t . \quad (3.22)$$

When plastic global analysis it is for braced frames the weld thickness is given by

$$a > 1,4 \cdot 0,7 \frac{(f_y / \gamma_{M0}) t}{f_u / \gamma_{Mw}} = 1,4 \cdot 0,7 \frac{(235 / 1,10) t}{360 / 1,25} = 0,73 t \approx 0,7 t , \quad (3.23)$$

and for unbraced frames

$$a > 1,7 \cdot 0,7 \frac{(f_y / \gamma_{M0}) t}{f_u / \gamma_{Mw}} = 1,7 \cdot 0,7 \frac{(235 / 1,10) t}{360 / 1,25} = 0,88 t \approx 0,9 t . \quad (3.24)$$

Similarly for the design of a weld loaded parallel to its length, the weld thickness may be calculated as

$$a > 0,85 \frac{\tau t}{f_w / \gamma_{Mw}} \approx 0,85 \frac{f_y / (\sqrt{3} \gamma_{M0}) t}{f_u / \gamma_{Mw}} = 0,85 \frac{235 / (1,1 * \sqrt{3}) t}{360 / 1,25} = 0,36 t \approx 0,4 t \quad (3.25)$$

where $\tau = V_{Sd} / (t h)$, V_{Sd} is the design shear force in weld.

4 STRUCTURAL MODELLING

Joint behaviour has a significant effect on the response of the structural frame and must be included in both the global analysis and design. The types of joint modelling with respect to their stiffness and resistance are summarised in Table 4.1. In the case of elastic global frame analysis, only the stiffness properties (the initial stiffness for the Serviceability Limit State and stability calculations and the secant stiffness for the Ultimate Limit State calculations) of the joint are relevant for the joint modelling. In the case of rigid-plastic analysis, the principal joint features are its resistance, and its rotational capacity both of which need to be checked. In all other cases, both the stiffness and the resistance properties should be included in the joint model. These different models are illustrated in Table 4.2 and Figure 4.1. For most applications, separate modelling of the connection and the web panel behaviour is not convenient, but may be useful in some cases.

Table 4.1 Types of joint modelling

STIFFNESS	RESISTANCE		
	Full-strength	Partial-strength	Pinned
Rigid	Continuous	Semi-continuous	-
Semi - rigid	Semi-continuous	Semi-continuous	-
Pinned	-	-	Simple

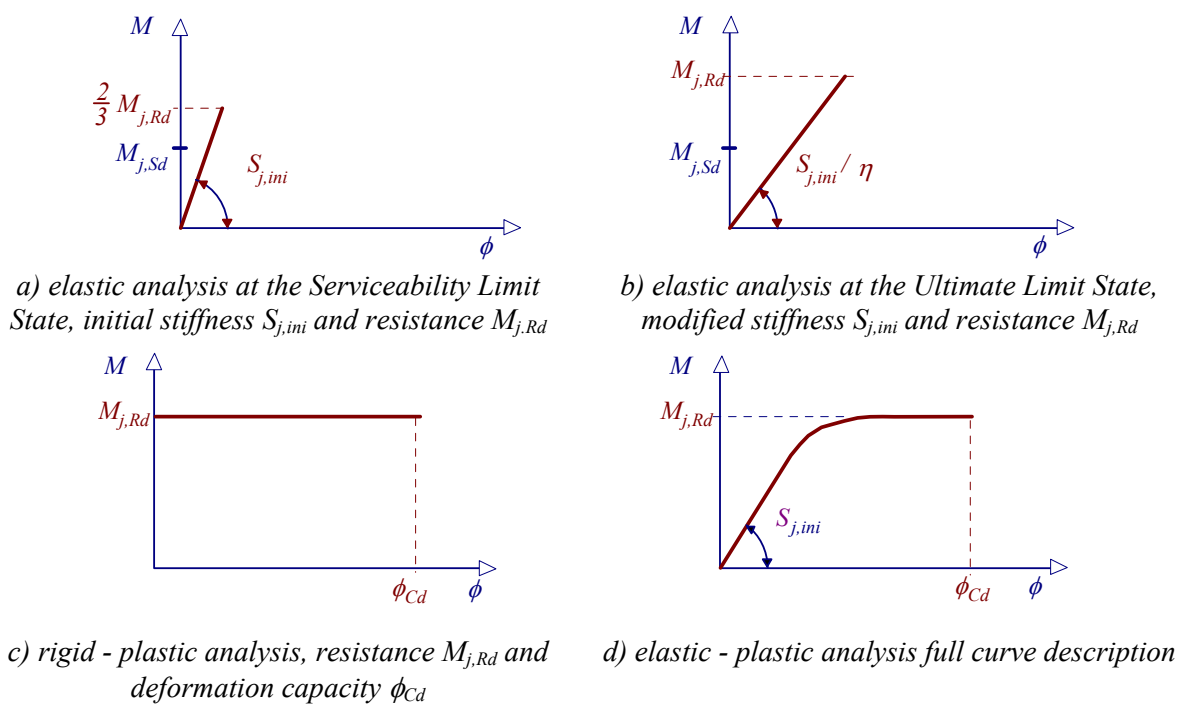

Figure 4.1 Design joint properties based on the type of global analysis

Table 4.2 Joint modelling and frame global analysis

MODELLING	TYPE OF FRAME ANALYSIS		
	Elastic analysis	Rigid-plastic analysis	Elastic-plastic analysis
Continuous	Rigid	Full-strength	Rigid/full strength
Semi-continuous	Semi-rigid	Partial-strength	Rigid/partial-strength Semi-rigid/full-strength Semi-rigid/partial-strength
Simple	Pinned	Pinned	Pinned

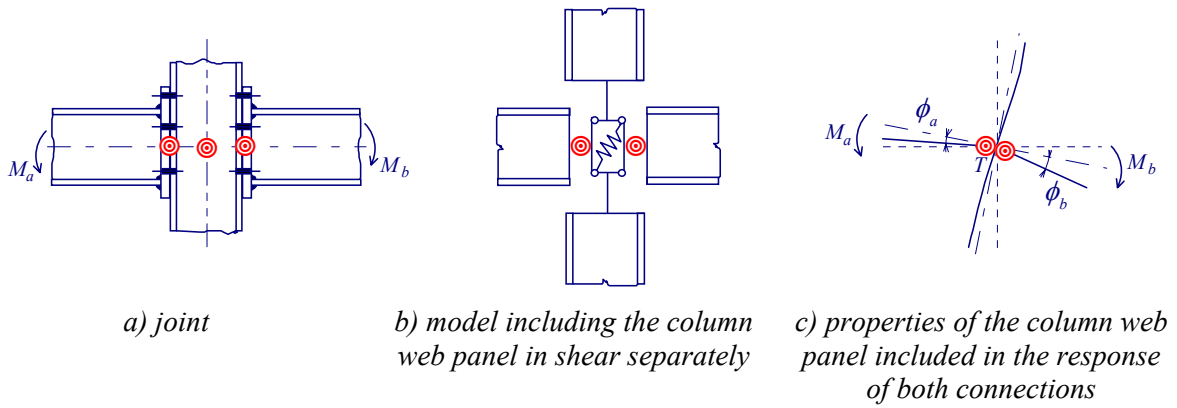

Figure 4.2 Modelling of joint by rotational springs

Table 4.3 Coefficients ξ and ς and lever arm r for estimation of initial stiffness and bending moment resistance of beam to column joints and column bases, see Q&A 4.1

Joint beam to column	Coefficient		Joint beam to column, base plate	Coefficient	
	ξ	ς		ξ	ς
	13,0	5		∞	> 7
	7,5	7		6	7
	8,5	5		7	-
	3	> 7		10	-
	3	> 7		35	-
	11,5	5		15	-
	11,5	5		14	-
	6,0	7		40	-
	5,5	5		20	5

Q&A 4.1 Preliminary Design of Connections

prEN 1993-1-8 gives rules for determining the behaviour of major axis, beam-to-column steel moment connections. Is there any other method, which can be used for preliminary design?

A simple way of predicting connection behaviour was developed by Steenhuis for preliminary design [Steenhuis, 1999]. Estimation of stiffness and resistance of the joint is based on the weakest component. The stiffness may be estimated by

$$S_{j.ini.app} = \frac{E r^2 t_{fc}}{\xi}, \quad (4.1)$$

where t_{fc} is the thickness of the column flange or base plate. The lever arm r is estimated as the distance between the centres of its beam flanges, see Table 4.3.

The moment resistance of the joint may be based on the column flange thickness t_{fc} which is assumed to be the weakest element

$$M_{j.Rd.app} = \frac{\zeta f_{y.fc} r^2 t_{fc}}{\gamma_{M0}}. \quad (4.2)$$

The factor ζ can be found in Table 4.3. To ensure the column flange is the weakest component it is assumed the end plate thickness t_p is thicker than column flange $t_p \geq t_{fc}$, the thickness of the column web stiffener t_{sc} is $t_{sc} \approx t_{fb}$ and the diameter of the bolts is larger than the thickness of the column flange $d \geq t_{fc}$.

Q&A 4.2 Use of Elastic Theory for Global Analysis of Structures

Is it allowed to use elastic methods for analysing a structure with connections designed by means of plastic theory?

Elastic global analysis may be used with connection designed plastically provided that the appropriate connection stiffness is taken into account in the elastic global analysis.

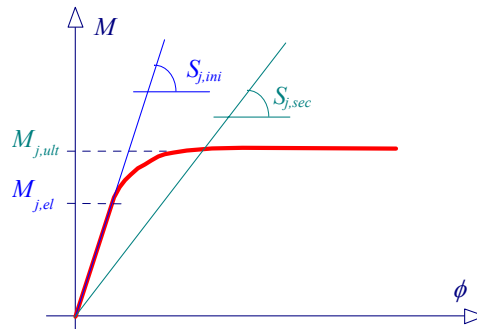

Figure 4.3 Initial and secant stiffness of connection

For example if the moment capacity of a connection is based on $M_{j,el}$ the tangent stiffness $S_{j,el}$ should be used in the analyses. However, if the moment capacity is based on $M_{j,ult}$ the secant stiffness $S_{j,sec}$ should be used.

In practice, the resistance of the elements is often based on a plastic stress distribution performed with elastic global analysis. The rotation capacity of a plastic hinge cross sections is implemented by classification of the section using the slenderness of the web and flanges. Class 2 is required for elastic analysis and the resistance is based on a plastic stress distributions. This procedure is simple and practical. It is based on engineering experience and not on an exact procedure of analysis. It is expected that the Ultimate Limit State will be reached on limited occasions only. The same procedure can be applied to connections. The resistance of all structural elements, members and connections, must satisfy the design criteria.

The elastic behaviour of an element is expected at the Serviceability Limit State. The load ratio of loads at the Ultimate Limit State and Serviceability Limit State for steel structures can be estimated as $((I*1,35+3*1,50)/4)/1,00 = 1,46$ and the ratio of plastic and elastic resistance of an I cross-sections is about $1,18/1,00 = 1,18$. Hence the check of elastic behaviour at the Serviceability Limit State is not necessary. This is not the case for composite members, where the check of elastic response at the Serviceability Limit State is part of the standard design procedure. The same principle is applied to the design of connections. It is reported [Zoetemeijer, 1983] that the beginning of non-linear behaviour of the end plates may be estimated at $2/3$ of the plastic bending moment resistance of a beam of rectangular cross section. For other connection types this ratio was observed in tests results. This estimation is conservative and safe when the yield stress f_y is used in the prediction model, see Figure 4.4.

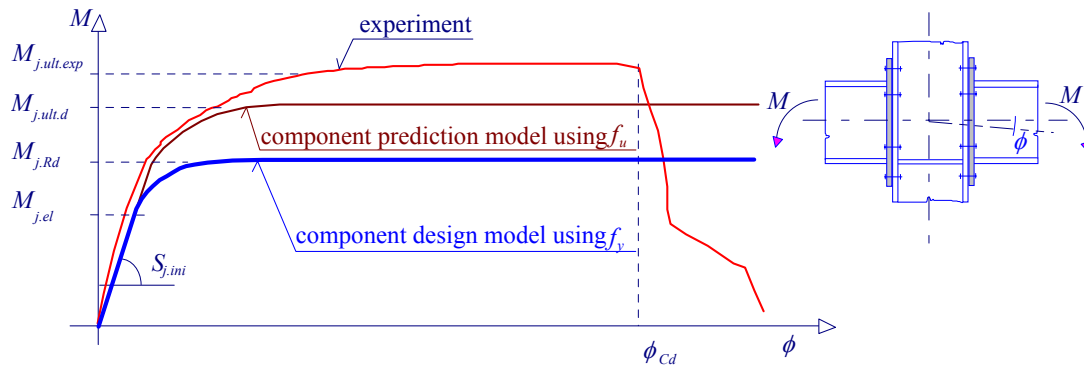

Figure 4.4 Prediction of the joint behaviour

A plastic force distribution is usually used in design, see Figure 4.5a. However, certain components can limit the rotational capacity of the connection. Methods to predict the rotational capacity of a connection from the deformation capacity of its component are currently under development. Therefore, simple deem to satisfy criteria for determining a connections rotational capacity are given in prEN 1993-1-8: 2003.

The components in the connection can be divided into two categories: ductile components (plate in bending, column web in shear, and column web in tension) and brittle components (bolts in shear and tension, welds and reinforcing bars). It is good engineering practice to over design the brittle components to increase the deformation capacity and safety. Elastic distribution is applied in the case when the brittle component limits the resistance of the connection, see Figure 4.5c. If the brittle component (bolt in second bolt row, for example) is placed in the middle of the joint, then the lower components need to remain elastic. In this case, an elastic plastic force distribution is applied to the connection, see third bolt row on Figure 4.5b.

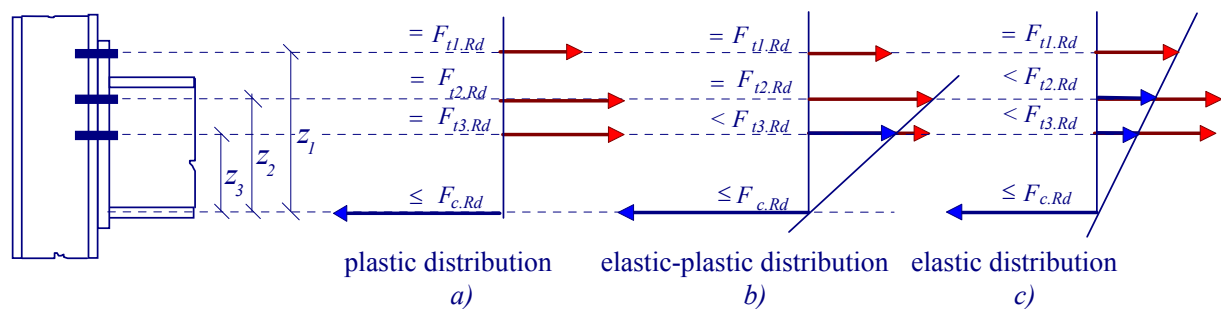

Figure 4.5 The modelling of distribution of internal forces inside the bolted end plate joint, a) plastic force distribution, b) elastic plastic force distribution, c) elastic force distribution

Q&A 4.3 Classification Criteria for Column Bases

Why are different limits used for the classification of beam-to-column connections and column bases in prEN 1993-1-8: 2003? Could you give the background to their classification system?

Connections may be classified according to their resistance, stiffness and rotation capacity, see Figure 4.6.

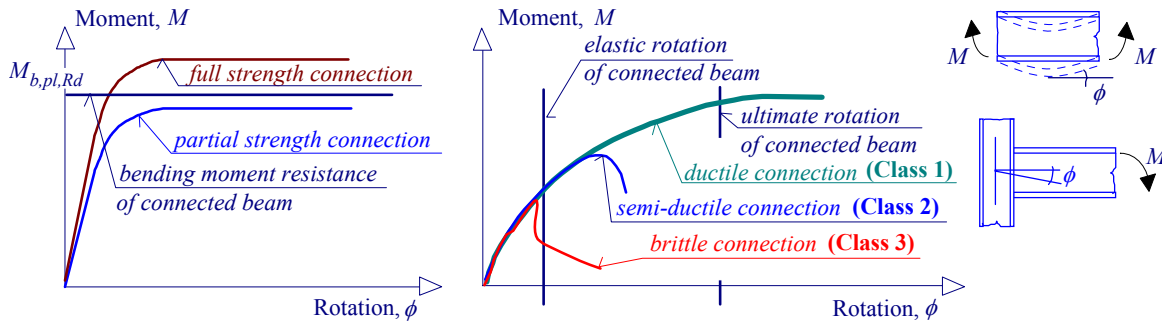

Figure 4.6 Classification of connections based on resistance and rotation capacity

The boundaries for the stiffness between rigid and semi-rigid connections are based on the required accuracy of the design (e.g. of the global analysis) of the member forces and connection check. The minimum stiffness of joints in a structural frame, which causes a change of the internal forces within the required accuracy limits, may be evaluated. This stiffness is the limit for rigid connections and all joints with higher stiffness can be modelled as rigid joints. For practical reasons, the limits for beam to column joints given in standards are conservative. For simplicity these values are scaled to the bending stiffness of the connected beams, see Figure 4.7. Following the above procedure limits have been developed between rigid and semi-rigid connections. Connections are assumed to be rigid if the buckling load of the structure is not less than 97,5% the buckling load of the same structure with rigid connections. The need to check deflections at the Serviceability Limit State is the reason for the different limits for unbraced ($\bar{S}_{j.ini,u} = 25$) and braced frames ($\bar{S}_{j.ini,b} = 8$). The pinned connection cannot be designed by independent checks on stiffness, resistance and rotation capacity. It is characterized by low stiffness ($\bar{S}_{j.ini,u} = 0,5$), low bending moment resistance and high rotation capacity ($\phi_{Cd} = 60 \text{ mrad}$).

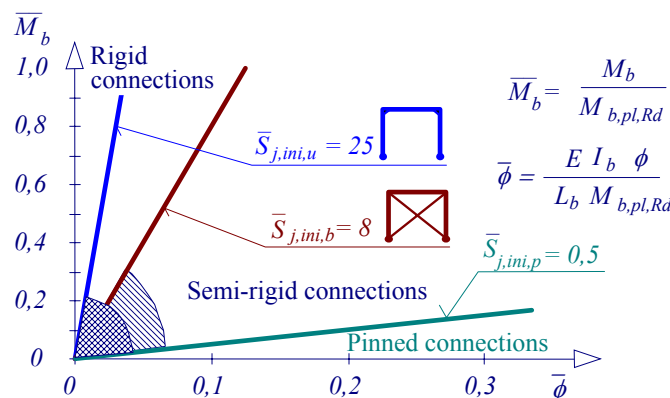

Figure 4.7 Classification of beam to column joints based on its bending stiffness

Similar calculation were performed on frames with semi-rigid column bases, see [Wald, Jaspert, 1999], to determine the classification limit for column bases. In this case the stiffness of the

column base is defined in terms of the stiffness of the connected column. Furthermore the resistance of the column is limited by its slenderness. The minimum stiffness of the column base depends on the relative slenderness $\bar{\lambda}$ of the column and is expressed as:

$$\text{for } \bar{\lambda} \leq 0,5 \quad \text{is the limit} \quad S_{j,ini} > 0, \quad (4.3)$$

$$\text{for } 0,5 < \bar{\lambda} < 3,93 \quad \text{is the limit} \quad S_{j,ini} \geq 7(2\bar{\lambda} - 1)E I_c / L_c, \quad (4.4)$$

$$\text{and for } 3,93 \leq \bar{\lambda} \quad \text{is the limit} \quad S_{j,ini} \geq 48 I_c / L_c. \quad (4.5)$$

The limit (4.5) is a conservative approximation and can be used for all columns. The limiting stiffness $12 E I_c / L_c$ may be used for unbraced frames compared of columns with a slenderness lower than $\bar{\lambda} = 1,36$, see Figure 4.8.

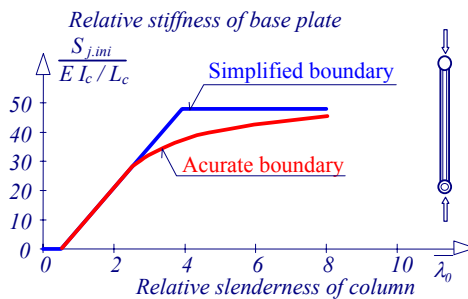

Figure 4.8 Prediction of column resistance based on the lower support bending stiffness

The limits for unbraced frames are banned on a limiting horizontal displacement. Base plates are assumed to be rigid if the horizontal displacement of the structure is not less than 90% of the horizontal displacement of the same structure with rigid connections. A study was undertaken on a portal frame with a flexible rafter. The results from this study are given in Figure 4.9.

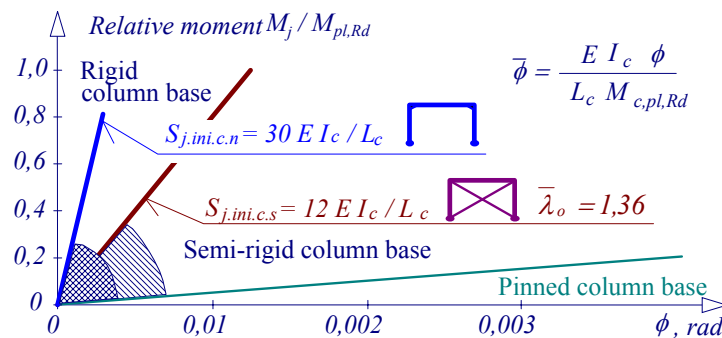

Figure 4.9 Classification of column bases based on bending stiffness

Q&A 4.4 Design of Connections Loaded by Low Forces

In the case of a connection subject to low forces, is it necessary to design it for a certain "reasonable" level of force?

Structural connections should be designed to transmit environmental, accidental and nominal forces. In the case of very low applied forces the integrity of the structure and load cases at erection should be taken into account. The resistance depends on the type of connection.

To prevent progressive collapse under accidental loading the model of the tie forces was introduced, see [BCSA 1996]. The example of tying the columns of the building is given in Fig. 4.10. The minimum tie force is taken as 75 kN .

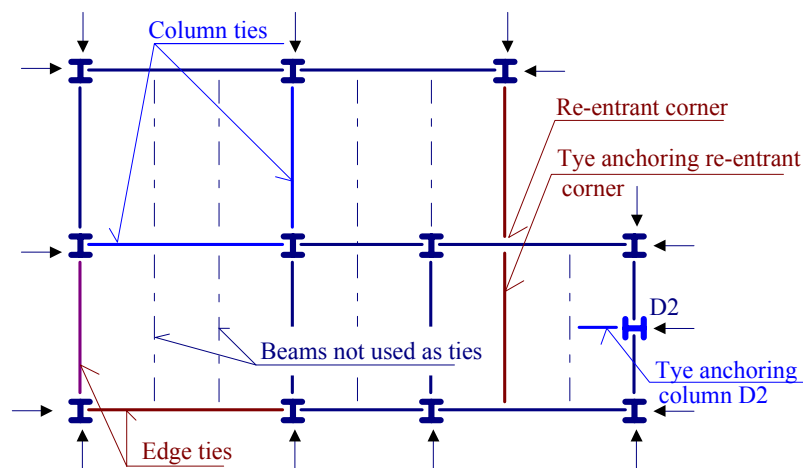
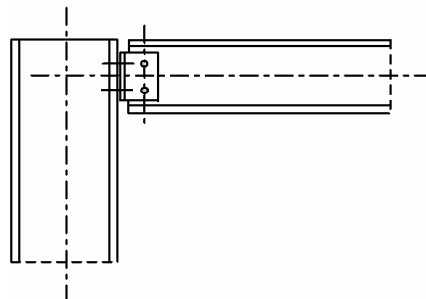

Figure. 4.10 Example of tying the columns of the building

Q&A 4.5 Modelling of Joint Eccentricity in Frame Design

Frames are usually modelled with a system of lines, joining the centres of sections. In the figure below, if the connection is designed as a pin may the column be designed as an axially loaded column?



The eccentricity of the connection is taken into account in the global analysis. Only the eccentricity of a bolted beam to column connection (end plate, web cleats and so on) to web of an open column may be neglected, see Figure 4.11. The eccentricity of a connection to a column flange as shown in the picture above needs to be taken into account.

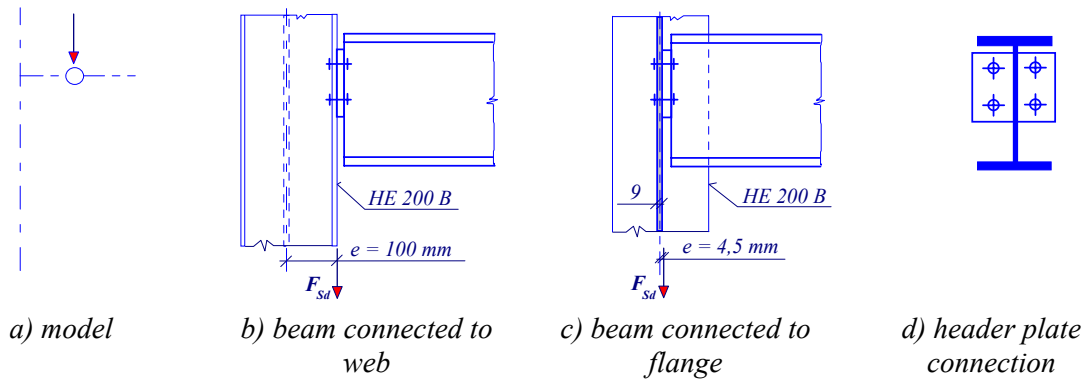

Figure 4.11 Example of the load eccentricity for column

The error in neglecting the eccentricity about the column weak axis is relatively high. The error may be estimated from the interaction of the normal force and bending moment (buckling of the column is neglected)

$$\frac{N_{Sd}}{N_{pl.Rd}} + \frac{N_{Sd} e}{M_{pl.Rd}} \leq 1, \quad (4.6)$$

The column normal force resistance is

$$N_{pl.Rd} = A f_y / \gamma_{M0} = 7\,808 \cdot 235 / 1,10 = 1668 \cdot 10^3 \text{ N}, \quad (4.7)$$

and column bending moment resistance is

$$M_{pl.z.Rd} = W_{pl.z} f_y / \gamma_{M0} = 200,3 \cdot 10^3 \cdot 235 / 1,10 = 42,8 \cdot 10^6 \text{ Nmm}. \quad (4.8)$$

The normal force resistance drops to 1419 kN with eccentricity $e = 4,5 \text{ mm}$, and the error in design resistance is 14,9%.

The error in neglecting bending about column strong axis can be calculated using column bending moment resistance

$$M_{pl.y.Rd} = W_{pl.y} f_y / \gamma_{M0} = 642,5 \cdot 10^3 \cdot 235 / 1,10 = 137,2 \cdot 10^6 \text{ Nmm}. \quad (4.9)$$

The normal force resistance drops to $752,8 \cdot 10^3 \text{ N}$ and the error in design resistance for eccentricity $e = 100 \text{ mm}$ is 54,9%.

5 SIMPLE CONNECTIONS

5.1 Design Philosophy

Connection design depends very much on the designer's decision regarding the method by which the structure is analysed. The latest draft of Eurocode 3 [prEN 1993-1-8: 2003] includes four approaches for the design of a structure in which the behaviour of the connection is fundamental. These design methods are defined as simple design, semi-continuous design, continuous design and experimental verification. Elastic, plastic and elastic-plastic methods of global analysis can be used with any of the first three approaches, see Chapter 4.

The joints are classified according to the method of global analysis and the type of joint model. This chapter is concerned with the design of simple joints where the method of global analysis may be elastic, rigid-plastic or elastic-plastic. Simple connections are defined as those connections that transmit end shear only and have negligible resistance to rotation and therefore do not transfer significant moments at the ultimate Limit State [BCSA 1996]. This definition underlies the design of the overall structure in which the beams are designed as simply supported and the columns are designed for axial load and the small moments induced by the end reactions from the beams. In practice, however, the connections do have a degree of fixity, which although not taken in to account in the design is often sufficient to allow erection to take place without the need for temporary bracing. The following four principal forms of simple connection are considered in this section:

- Double angle web cleats
- Flexible end-plates (header plates)
- Fin plates
- Column splices

To comply with the design assumptions, simple connections must allow adequate end rotation of the beam as it takes up its simply supported deflected profile and practical lack of fit. At the same time this rotation must not impair the shear and tying (for structural integrity – see below) capacities of the connection. In theory a 457 mm deep, simply supported beam spanning 6,0 m will develop an end rotation of 0,022 radians (1,26°) when carrying its maximum factored load. In practice this rotation will be considerably smaller because of the restraining action of the connection. When the beam rotates it is desirable to avoid the bottom flange of the beam bearing against the column as this can induce large forces in the connection. The usual way of achieving this is to ensure that the connection extends at least 10 mm beyond the end of the beam.

5.2 Structural Integrity

The partial collapse of Ronan Point in the UK in 1968 alerted the construction industry to the problem of progressive collapse arising from a lack of positive attachment between principal elements in a structure [BS 5950]. Structures are required to have a minimum robustness to resist accidental loading. One method of achieving this is by tying all the principal elements of a structure together. This means that the beam-to-column connections of a steel frame must be capable of transferring a horizontal tying force in order to preserve the integrity of the structure and prevent progressive collapse in the event of accidental damage.

5.3 Design Procedures

The design of these simple connections is based on the principles and procedures adopted in Eurocode 3 Part 1.8 [prEN 1993-1-8: 2003]. Typical practice in terms of type and nature of fixings and connection types varies between the member countries of the Community. This section deals with the general principles applicable to all types of simple connection. Detailed design procedures in the form of a check list are presented for flexible end plates and fin plates. The relevant formulae may be found in the Eurocode.

5.4 Beam-to-column connections

5.4.1 Double angle web cleats

Typical bolted double angle cleat connections about both the major and minor axis of a column are shown in Figure 5.1. These types of connection are popular because they have the facility

to provide for minor site adjustments when using untorqued bolts in 2 mm clearance holes. Normally the cleats are used in pairs. Any simple equilibrium analysis is suitable for the design of this type of connection. The one recommended in this publication assumes that the line of action of shear transfer between the beam and the column is at the face of the column. Using this model the bolt group connecting the cleats to the beam web must be designed for the shear force and the moment produced by the product of the end shear and the eccentricity of the bolt group from the face of the column. The bolts connecting the cleats to the face of the column should be designed for the applied shear only. In practice the cleats to the column are rarely critical and the design is almost always governed by the bolts bearing on to the web of the beam. The rotational capacity of this connection is governed largely by the deformation capacity of the angles and the slip between the connected parts. Most of the rotation of the connections comes from the deformation of the angles while fastener deformation is very small. To minimise rotational resistance (and increase rotational capacity) the thickness of the angle should be kept to a minimum and the bolt cross-centres should be as large as is practically possible.

When connecting to the minor axis of a column it may be necessary to trim the flanges of the beam but this does not change the shear capacity of the beam. During erection the beam with the cleats attached is lowered down the column between the column flanges.

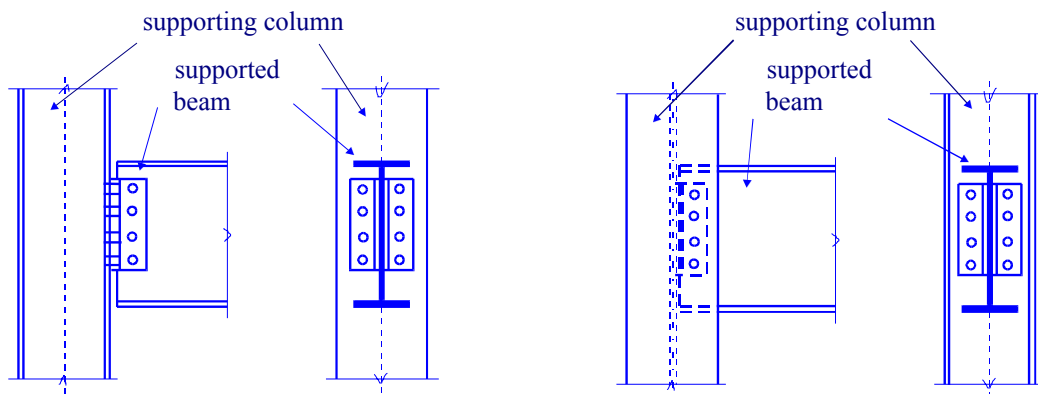

Figure 5.1 Typical major and minor axis double angle cleat connections

5.4.2 Single angle web cleats

Single angle web cleats are normally only used for small connections or where access precludes the use of double angle or end-plate connections.

This type of connection is not desirable from an erector's point of view because of the tendency of the beam to twist during erection. Care should be taken when using this type of connection in areas where axial tension is high. The bolts connecting the cleat to the column must also be checked for the moment produced by the product of the end shear force and the distance between the bolts and the centre line of the beam.

5.4.3 Flexible end-plates

Typical flexible end-plate connections about the major and minor axis of a column are shown in Figure 5.2. These connections consist of a single plate fillet welded to the end of the beam and site bolted to either a supporting column or beam. This connection is relatively inexpensive but has the disadvantage that there is no room for site adjustment. Overall beam lengths need to be fabricated within tight limits although packs can be used to compensate for fabrication and erection tolerances. The end-plate is often detailed to extend to the full depth of the beam but there is no need to weld the end-plate to the flanges of the beam.

Sometimes the end-plate is welded to the beam flanges to improve the stability of the frame during erection and avoid the need for temporary bracing. This type of connection derives its flexibility from the use of relatively thin end-plates combined with large bolt cross-centres. An 8 mm thick end-plate combined with 90 mm cross-centres is usually used for beams up to approximately 450 mm deep. For beams 533 mm deep and over a 10 mm thick end-plate combined with 140 mm

cross-centres is recommended. The local shear capacity of the web of the beam must be checked and, because of their lack of ductility, the welds between the end-plate and beam web must not be the weakest link.

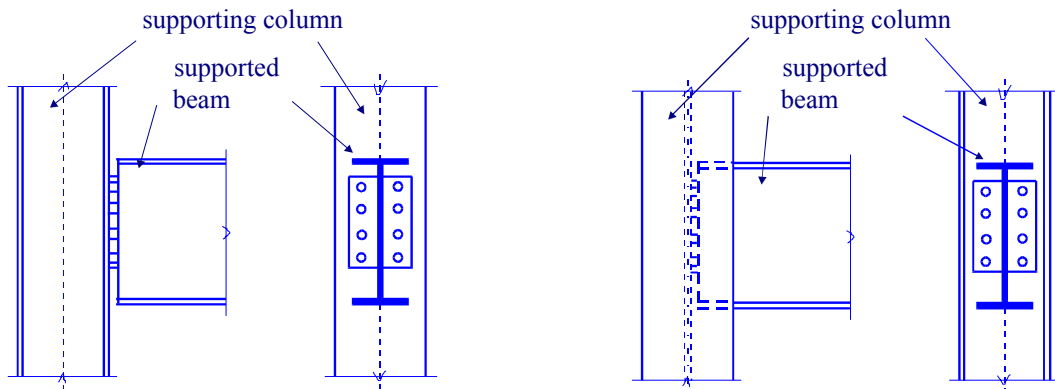

Figure 5.2 Typical major and minor axis flexible end-plate connections

Detailed Design Procedure

1. Shear capacity of bolt group

The shear capacity of the bolt group must be greater than the reaction at the end of the beam. The shear capacity of either the threaded or unthreaded portion of the bolt should be checked.

2. Shear and bearing capacity of the end plate

The shear capacity of the end plate must be greater than half the reaction at the end of the beam. The bearing capacity of the end plate must be greater than half the reaction at the end of the beam.

3. Shear capacity of the beam web

The shear capacity of the beam web connected to the end plate must be greater than the reaction at the end of the beam.

4. Capacity of fillet welds connecting end plate to beam web

The capacity of the fillet weld must be greater than the reaction at the end of the beam.

5. Local shear and bearing capacity of column web

The local shear capacity of the column web must be greater than half the sum of the beam end reactions either side of the column web. The bearing capacity of the column web must be greater than half the sum of the reactions either side of the column web divided by the number of bolt rows.

6. Structural integrity requirements

The tension capacity of the end plate, beam web and bolt group must be greater than the tie force.

5.4.4 Fin plates

A more recent development, which follows both Australian and American practice has been the introduction of the fin plate connection. This type of connection is primarily used to transfer beam end reactions and is economical to fabricate and simple to erect. There is clearance between the ends of the supported beam and the supporting beam or column thus ensuring an easy fit. Figure 5.3 shows a typical bolted fin plate connection to the major and minor axes of a column. These connections comprise a single plate with either pre-punched or pre-drilled holes that is shop welded to the supporting column flange or web.

Considerable effort has been invested in trying to identify the appropriate line of action for the shear. There are two possibilities, either the shear acts at the face of the column or it acts along the centre of the bolt group connecting the fin plate to the beam web. For this reason all critical sections should be checked for a minimum moment taken as the product of the vertical shear and the distance between the face of the column and the centre of the bolt group. The critical sections are then checked for the resulting moment combined with the vertical shear. The validation of this and other design assumptions were checked against a series of tests on fin plate connections. The results of these tests concluded that the design approach was conservative and gave adequate predictions of strength. The tests also showed that fin plates with long projections had a tendency to twist and fail by lateral torsional buckling. Fin plate connections derive their in-plane rotational capacity from the bolt

deformation in shear, from the distortion of the bolt holes in bearing and from the out-of-plane bending of the fin plate.

Detailed Design Procedure

1. Capacity of the bolt group connecting the fin plate to the web of the supported beam

The bearing capacity per bolt must be greater than the resultant force on the outermost bolt due to direct shear and moment.

2. Strength of the fin plate at the net section under bearing and shear

The shear capacity of the fin plate must be greater than the reaction at the end of the beam. The elastic modulus of the net section of the fin plate must be greater than the moment due to the end reaction and the projection of the fin plate.

3. Strength of the supported beam at the net section

The shear capacity of the supported beam must be greater than the reaction at the end of the beam. For long fin plates the resistance of the net section must be greater than the applied moment.

4. Strength of weld connecting fin plate to supporting column

The leg length of the fillet weld(s) must be greater than 0,8 times the thickness of the fin plate.

5. Local shear check of column web

The local shear capacity of the column web must be greater than half the sum of the beam end reactions either side of the column web.

6. Buckling resistance of long fin plates

The buckling resistance moment of the fin plate must be greater than the moment due to the end reaction and the projection of the fin plate.

7. Structural integrity

The tension capacity of the fin plate and the beam web must be greater than the tie force. The bearing capacity of the beam web or fin plate must be greater than the tie force and the tying capacity of the column web must be greater than the tie force.

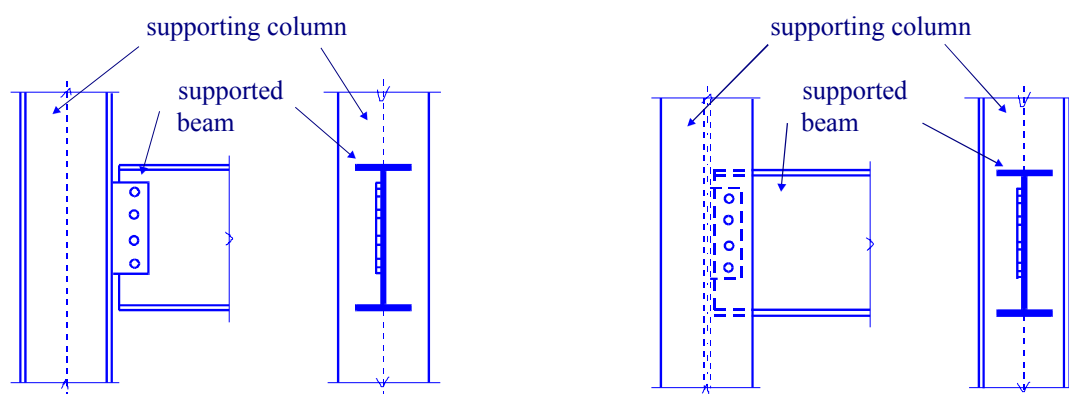

Figure 5.3 Typical major and minor axis fin-plate connections

5.5 Beam-to-beam connections

There are three forms of beam-to-beam connection, double angle web cleats, flexible end-plates and fin plates and the comments given in sections 5.4.1, 5.4.3 and 5.4.4 on similar beam-to-column connections will apply. The following sections highlight some of the additional items that need to be considered when designing and using beam-to-beam connections

5.5.1 Double angle web cleats

Figure 5.4 shows typical beam-to-beam double angle web cleat connections with single notched and double notched beams. Where the top flanges of the connected beams are at the same level, as in the case of the connection shown in Figure 5.4, the flange of the supported beam is notched and the web must be checked allowing for the effect of the notch. The top of the web of the notch, which is in compression, must be checked for local buckling of the unrestrained web. For

beams, which are not laterally restrained, a more detailed investigation is required on the overall stability of the beam with notched ends against lateral torsional buckling.

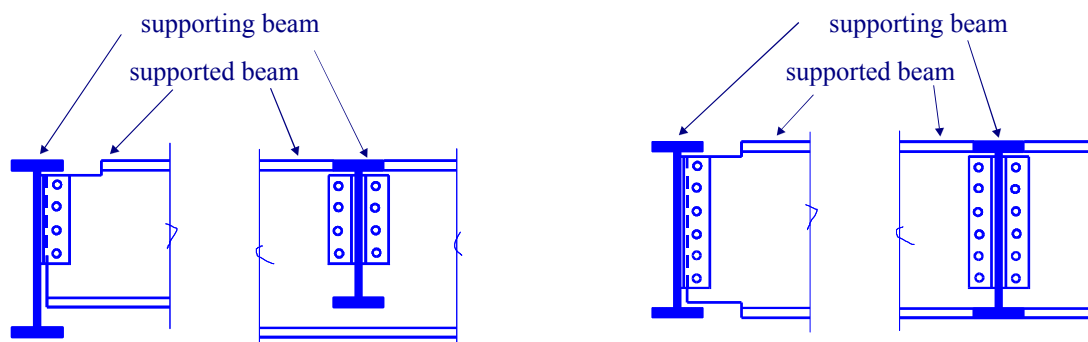

Figure 5.4 Single and double notched beam to beam connections

The web angle cleat can become cumbersome when used to connect unequal sized beams. In this case it is necessary to notch the bottom flange of the smaller beam to prevent fouling of the bolts. Alternatively the cleat of the larger beam could be extended and the bolts placed below the bottom of the smaller beam.

5.5.2 Flexible end-plates (header plates)

This type of connection is shown in Figure 5.4. Like the double angle cleat connection, the top flange of the supported beam is notched to allow it to fit to the web of the supporting beam. If both beams are of a similar depth both flanges are notched. In either case if the length of the notches exceed certain limits the unrestrained web and beam must be checked for lateral torsional buckling.

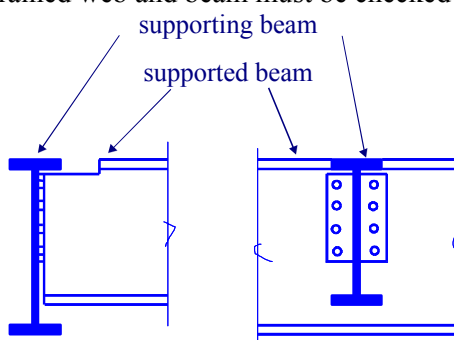

Figure 5.5 Typical beam to beam flexible end-plate connection

In practice the end-plate is often detailed to extend to the full depth of the notched beam and welded to the bottom flange. This makes the connection relatively stiffer than a partial depth end-plate but provided the end-plate is relatively thin and the bolt cross centres are large, the end-plate retains sufficient flexibility to be classified as a simple connection.

If the supporting beam is free to twist there will be adequate rotational capacity even with a thick end-plate. In the cases where the supporting beam is not free to twist, for example in a double sided connection, the rotational capacity must be provided by the connection itself. In such cases thick, full depth end-plates may lead to overstressing of the bolts and welds. Both partial and full depth end-plates derive their flexibility from the use of relatively thin end-plates combined with large bolt cross centres. Normally end-plates no more than 8 mm or 10 mm thick should be used.

5.5.3 Fin plate connections

Typical bolted fin plate connections are shown in Figure 5.6. The comments made in section 5.4.4 on beam-to-column fin plates apply to beam-to-beam fin plates. In addition, a beam-to-beam fin plate connection requires either a long fin plate as shown in Figure 5.6a or a notched beam as shown in Figure 5.6b. The designer must therefore choose between the reduced capacity of a long fin plate

and the reduced capacity of a notched beam. Another minor consideration is the torsion induced when fin plates are attached to one side of the supported beam web. However, tests have shown that in these cases the torsional moments are small and can be neglected.

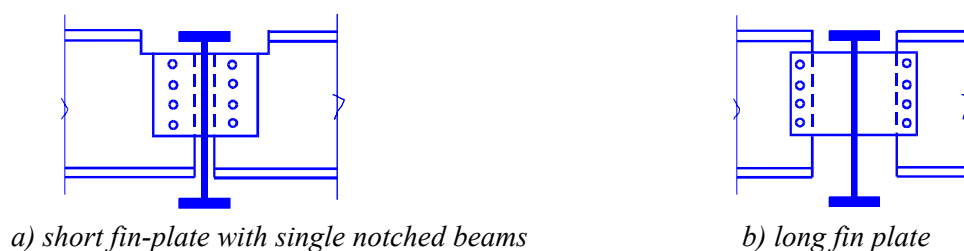

Figure 5.6 Beam to beam fin plate connections

5.6 Column splices

This section presents design requirements for column splices in braced multi-storey buildings. In this type of building column splices are required to provide continuity of both strength and stiffness about both axes of the columns. In general they are subject to both axial compression and moments resulting from the end reactions of the beams. If a splice is positioned near to a point of lateral restraint (i.e. within say 500 mm above the floor level), and the column is designed as pinned at that point the splice may simply be designed for the axial load and any applied moments. If, however, the splice is positioned away from a point of lateral restraint (i.e. more than 500 mm above the level of the floor), or end fixity or continuity has been assumed when calculating the effective length of the column, the additional moment that can be induced by strut action must be taken in to account.

Two types of splices are considered in this section, those where the ends of the members are prepared for contact in bearing, and those where ends of the members are not prepared for contact in bearing. In both cases the column splices should hold the connected members in line and wherever practicable the members should be arranged so that the centroidal axis of the splice material coincides with the centroidal axes of the column sections above and below the splice.

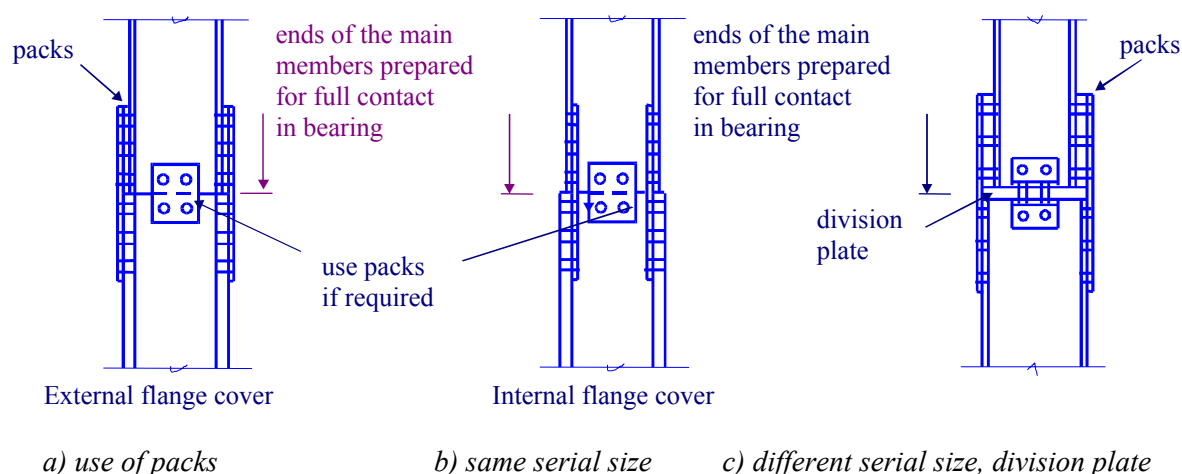

Figure 5.7 Column splice with ends prepared for bearing

5.6.1 Ends prepared for contact in bearing

Typical details for this type of column splice are shown in Figure 5.7. In all three cases the splice is constructed using web and flange cover plates and packs are used to make up any differences in the thickness of the web and the flanges. The flange cover plates may be placed on either the outside or the inside of the column. Placing the cover plates on the inside has the advantage of reducing the overall depth of the column. Each column splice must be designed to carry axial compressive forces, the tension (if any) resulting from the presence of bending moments and any horizontal shear forces.

The ends of the columns are usually prepared for full contact, in which case compressive forces may be transmitted in bearing. However, it is not necessary to achieve an absolutely perfect fit over the entire area of the column. Columns with saw cut ends are adequately smooth and flat for bearing and no machining is required. This is because after erection the ends of the column bed down as successive dead loads are applied to the structure. The cover plates provide continuity of stiffness and are designed to resist any tension where the presence of bending moments is sufficiently high to overcome the compressive forces in the column. Tension forces must be allowed for. The horizontal shear forces that arise from the moment gradient in the column are normally resisted by the friction across the bearing surfaces of the two columns and by the web cover plates. Wind forces on the external elevations of buildings are normally taken directly in the floor slab. It is rare for column splices in simple construction to transmit wind shears.

5.6.2 Ends not prepared for contact in bearing

Typical details for this type of column splice are shown in Figure 5.8. Both diagrams show that the column above and below the splice is the same serial size. In this case the splice is constructed using web and flange cover plates and where required packs are used to make up the differences in the web and flange thickness. Where columns of different serial size are to be connected multiple packs are necessary to take up the dimensional variations. For this type of splice all the forces and moments are carried by the cover plates and no load is transferred through direct bearing. The axial load in the column is normally shared between the flange and web cover plates in proportion to their areas while any bending moments are normally carried by the flange cover plates alone.

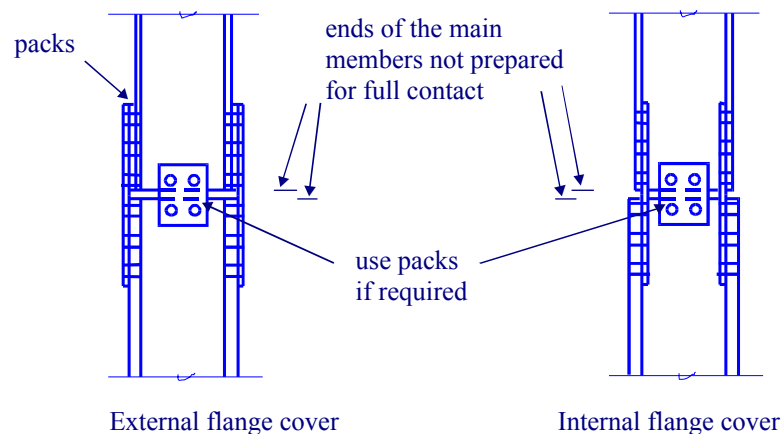

Figure 5.8 Column splice with ends not prepared for bearing

Q&A 5.1 Bolt bearing resistance with respect to tolerances

Figure T.5.5 of the execution standard [ENV 1090-1] allows a tolerance of $\Delta = \pm 5 \text{ mm}$ for the position of a group of boltholes. Should this variation be taken into account when calculating the bearing capacity of a bolt group? For example:

Bearing capacity assuming $\Delta = \pm 0 \text{ mm}$

The bearing capacity of a single bolt is given by the following expression:

$$F_{b,Rd} = \frac{2,5 \alpha d t f_u}{\gamma_{Mb}}$$

Where for the above example:

$$d = 12 \text{ mm}$$

$$d_o = 13 \text{ mm}$$

$$e_1 = 1,2 d = 1,2 \times 13 = 15,6 \text{ mm}$$

$$\alpha = e_1 / 3d_o = 15,6 / (3 \times 13) = 0,4$$

Bearing capacity assuming $\Delta = -5\text{mm}$

Where for the same example:

$$d = 12 \text{ mm}$$

$$d_o = 13 \text{ mm}$$

$$e_1 = 1,2 d - 5 = 1,2 \times 13 - 5 = 10,6 \text{ mm}$$

$$\alpha = e_1 / 3 d_o = 10,6 / (3 \times 13) = 0,272$$

Compared to the first example the second gives a capacity, which is 32% lower as a result of allowing for the tolerance. Should a reduction in edge and end distances etc. be taken when calculating the capacity of a connection?

Tolerances are not usually taken into account in the design of the connection. It is assumed that the tolerances are small in comparison to the edge and end distances and that the reduction in capacity is also small and can be accommodated by the partial safety factor.

Q&A 5.2 Angles connected by one or two bolts

How it is possible, that the tension resistance of the net section of an angle with one bolt is greater than that with two bolts? See the simple example below.

Input data $A = 480 \text{ mm}^2$

L 50×5 $t = 5 \text{ mm}$

$$d_o = 14 \text{ mm}$$

$$e_2 = 25 \text{ mm}$$

$$f_u = 510 \text{ MPa}$$

According to ENV 1993-1-1 (clause 6.2.3) the tension resistance of the net section is checked: for one bolt (See clause 3.10.3(2) and Table 3.8 in ENV 1993-1-8):

$$A_{\text{eff}} = 2(e_2 - 0,5 d_o) t = 2 \cdot (25 - 7) \cdot 5 = 180 \text{ mm}^2$$

$$N_{u,Rd} = \frac{A_{\text{eff}} f_u}{\gamma_{M2}} = \frac{180 \cdot 510}{1,25} = 73\,440 \text{ N}$$

for two bolts: (See clause 6.5.2.3 and Table 6.5.1 in ENV 1993-1-8):

$$\beta_{\text{eff}} = 0,4$$

$$A_{\text{eff}} = \beta_2 A_{\text{net}} = \beta_2 (A - d_o t) = 0,4 (480 - 14 \cdot 5) = 164 \text{ mm}^2$$

$$N_{u,Rd} = \frac{A_{\text{eff}} f_u}{\gamma_{M2}} = \frac{164 \cdot 510}{1,25} = 66\,912 \text{ N}$$

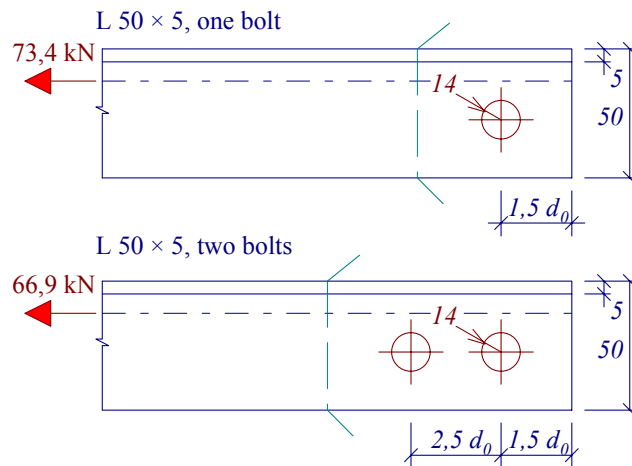

Figure 5.9 Angle connected with one and two bolts

Numerous tests have been carried out on angles connected by one and two bolts. These tests have shown that the resistance of an angle connected by a single bolt is higher than one connected by two or more bolts. The reasons for this are unclear but is possible due to the additional moments that are attracted by connection with more than one bolt.

Q&A 5.3 Rotation capacity

How do simple connections derive their rotational capacity?

Cleated connections derive their ductility from having reactively thin cleats (8 mm or 10 mm thick) and bolts in the supporting member, which are at reasonable cross centres (100 mm + beam web thickness).

Similarly, it is usual to use relatively thin end-plates (8 mm or 10 mm) and bolt cross centres of 90 mm or 140 mm to ensure that an end-plate connection has adequate flexibility and ductility to be classified as a 'simple connection'.

Ductility in a fin plate is achieved by ensuring a bearing mode of failure in either the fin plate or beam web. This is usually achieved by adopting the following detailing requirements:

- the thickness of the fin plate or beam web is
 - $\leq 0,42 d$ (for S355 steel)
 - $\leq 0,50 d$ (for S275 steel), where d is bolt diameter,
- all end and edge distances on the plate and the beam web are at least $2 d$
- 8.8 bolts are used, un-torqued and in clearance holes
- the fillet weld leg length is at least $0,8$ times the thickness of the fin plate.

The rotational capacity of the beam to column connection may be very roughly assumed as the rotation limited by thatching of the lower flange of the beam to the column.

Q&A 5.4 Structural Integrity

What method should be used to determine the tying capacity of simple connections and what is the background to this method?

Reference [SCI, 2002] gives a method for calculating the tying capacity of double angle web cleat connection and flexible end-plate connections. The method for double angle web cleat connections is based on the large displacement analysis of the cleats in tension [Carril et al, 1994] using the deformed shape shown in Figure 5.10. The main features of this approach are:

- The potential magnitude of the displacement δ , ignoring second order effects. Displacement δ defines the displaced geometry of the web cleats.
- These displacements reduce the eccentricities on the web cleats. Part of the tying force is carried by tension in the legs of the cleats.
- There are four critical sections in each cleat, which are subject to high plastic stains under the combined action of shear, tension and moment. Two are located at, or near, the bolt centrelines; two are located at the tips of the radiused portion of the heel of the cleat.

A programme of tests was carried out to verify this approach the details of which are given in the reference. Comparison between the method and the test results showed that the method gives an adequate margin of safety.

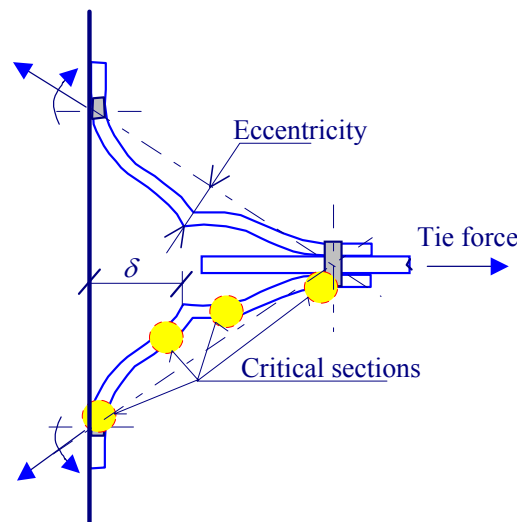

Figure 5.10 Double angle web cleats under tension

Generally, it will be found that the tying capacity of a web cleat connection is adequate. This is because of its ability to accept large deformations before failure. However, if the connection is unable to carry large tying forces, then extra capacity can be achieved by increasing the thickness of the cleat and/or by reducing the distance between the bolt cross-centres in the support. In both cases consideration should be given to the increase in the rotational stiffness of the connection.

Similarly the method for flexible end-plate connections is based on a large displacement analysis of the end-plate in tension. The deformed shape of the end-plate is shown in Figure 5.11. The features of this approach are:

- Considerable deformation can arise but only if there is rotation of the hinges at the toes of the welds. These regions may well have suffered some embrittlement from fast cooling after welding.
- These displacements do reduce the eccentricities within the connection but they do offer an alternative membrane path for some of the tying force. However, this membrane restraint is only available if the end plate is bolted to a more substantial plate or flange. For general solution this membrane action has been ignored.

- There are four critical sections in the plate. Since membrane action is being discounted these need only be considered under moment. (Moment/shear interaction will exist but need not be considered because the applied shear is only a small proportion of its shear capacity.)

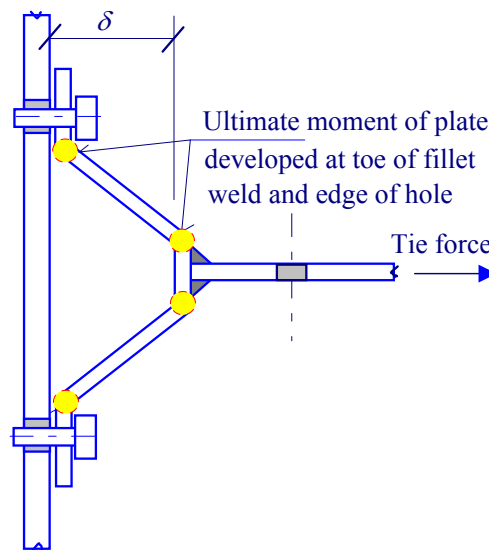

Figure 5.11 End-plate under tension

Once again a programme of tests was carried out to verify this approach. Details of the tests are given in reference [Jarrett, 1990]. Although the ratio of experimental capacity to calculated capacity varied considerable the tests proved that the method is conservative. The reason for the variability is not clear but may be due to the unquantified and variable membrane action.

The tying capacity of an end plate is generally lower than that of a web cleat connection or a fin plate. The tying capacity can be as low as 35% of the connection's shear capacity. For connections to I-section columns the critical mode of failure will be the tension capacity of the end-plate. To increase the capacity the solution will generally involve either increasing the thickness of the end-plate or reducing the cross centre distance between the bolts.

In both methods because the analysis relies on gross deformations the prying forces developed in the bolts are generally higher than methods based on the more traditional approaches. Thus a simple design check is introduced for both connections that ensures that the nominal tensile stress of bolts does not exceed its tensile resistance in interaction with shear acting forces. The tying capacity of a fin plate connection can be determined by simple structural analysis.

6 MOMENT CONNECTIONS

Moment connections are designed to transfer bending moments, shear forces and sometimes normal forces. The design strength and stiffness of a moment connection are defined in relation to the strength and stiffness of the connected members. The design strength of a moment connection may be full-strength (i.e. the moment capacity of the connection is equal to or larger than the capacity of the connected member) or partial-strength (i.e. the moment capacity of the connection is less than that of the connected member). Similarly the stiffness of a moment connection can be rigid or semi-rigid compared to the stiffness of the connected member.

The rotation capacity of the structure may be provided by either the connection or the connected member.

6.1 Development of the component method

In the past connections were designed as either pinned or rigid, full strength connections. Considerable work on connection behaviour has been completed and the concepts of semi-rigid design and partial strength design have been developed, which model more accurately the true behaviour of connections. These models have been developed into a comprehensive set of design rules which have been introduced into Eurocode 3 part 1.8 [prEN 1993-1-8, 2003]. These rules allow the designer to calculate the strength, stiffness and deformation capacity of moment connections. The following steps are required to design a moment connection:

- Determine the path of the forces through the connection. E.g. the tensile force in the top flange of the beam shown in Figure 6.1 must pass through the fillet welds of the connected end plate, the end plate in bending, the bolts in tension, the column flange in bending, the column web in tension, the column web in shear and the column web in compression, in order to balance the compression force coming from the beam compression flange. Furthermore the path of other forces (e.g. the shear force from the beam) has to be determined in a logical way. Of course the forces in the connection must be in equilibrium with the applied bending moment, shear force and /or the normal force acting on the connection.
- Once the path of the forces is determined, the strength of every part or component of the connection in this path must be calculated. The component in the chain with the lowest strength governs the strength of the connection (e.g. the tensile force in the top beam flange).
- The stiffness of the connection depends on the deformations of the components in the path that the forces follow. The deformation of each component gives the stiffness of the connection.
- The third important mechanical property of a connection is its deformation capacity. Deformation capacity is usually provided by plastic deformation of one or more components. If the strength of the connection clearly exceeds the strength of one of the connected members, the designer can rely on the deformation capacity coming from the connected member, e.g. the formation of a plastic hinge in the beam.

After the mechanical properties of all components have been determined, the various components can be assembled to determine the strength, stiffness and deformation capacity of the whole connection. The above method for the determination of the mechanical properties of the connection is called the component method. Rules for calculating the strength, stiffness and deformation capacity of each component are given in prEN 1993-1-8.

The principles of the component method are based on Zoetemeijer's work [Zoetemeijer, 1983b]. Later, other researchers worked on this method to determine the mechanical properties of more components and to refine the calculation methods, in order to obtain more accuracy in the description of the mechanical behaviour. Furthermore many tests were carried out to validate many different connection configurations. For further study see the references at the end of this publication.

The accuracy of the component method depends on the accuracy of the description of the basic components and on the quality of the assembling process. It is assumed that the component properties are independent. However, some components do not act independently, but influence others. For hand calculation this can only be accounted for in a simplified way, because the general approach results in a complicated iterative calculation procedure. This is not a problem for software. An example of the components for a bolted beam to column connection is given in Figure 6.1.

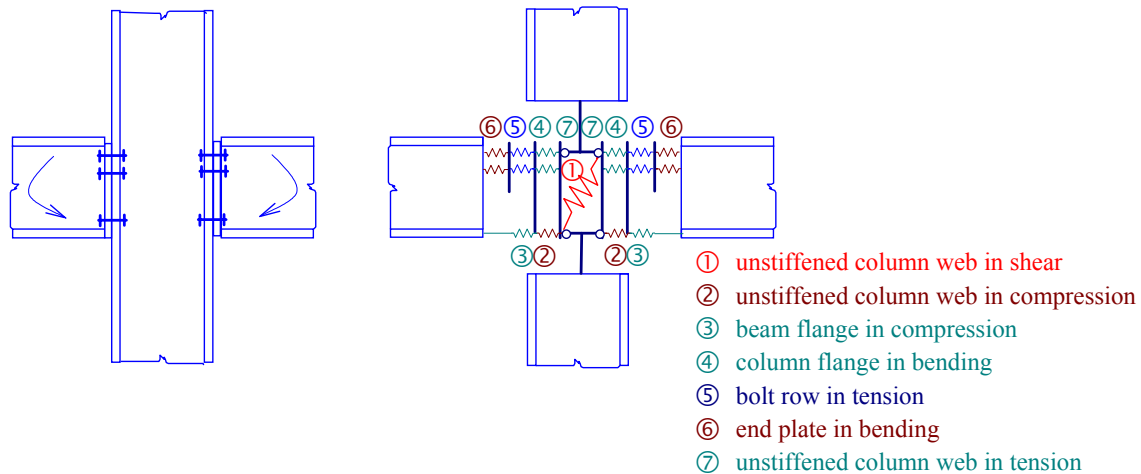

Figure 6.1 Components represented by springs in a bolted beam to column joint

6.2 Practical application of the component method

The component method allows the designer to analyse many different connection configurations. It enables the design of more economical connections than the traditional design methods based on tables (that could only be used for a limited number of connection configurations). The component method is complex and requires considerable effort even for the simplest moment connection. For practical application, therefore several computer programs have been developed, which can quickly determine a connection's mechanical properties. These computer programs can also be used to examine the effects that small changes have on a connection's strength, stiffness and deformation capacity. It is noted, however, that before using such programs, the designer must check that the software has been validated.

6.3 Determination of the connection's strength, stiffness and rotational capacity

As indicated above, the properties needed for the global analysis of a structure are the bending moment strength (resistance) $M_{j,Rd}$, the deformation / rotational stiffness S_j and the deformation / rotational capacity ϕ_{cd} . Figure 6.2 gives an example of a beam to column connection and its moment rotational diagram. In tests, the first part of the moment rotational diagram (representing the stiffness), is usually linear. However, the linear elastic curve deviates from its straight line at low bending moments [Wald, Steenhuis, 1993]. This is due to local plasticity caused by stress concentrations and residual stresses. In prEN1993-1-8 it is assumed that up to 2/3 of the calculated moment resistance the behaviour is elastic, following the straight line determined by the calculated (initial) stiffness.

After reaching 2/3 of the moment resistance, the stiffness is reduced until the moment resistance $M_{j,Rd}$ is reached. Rules are given in prEN1993-1-8, see also the question 6Q&A1.

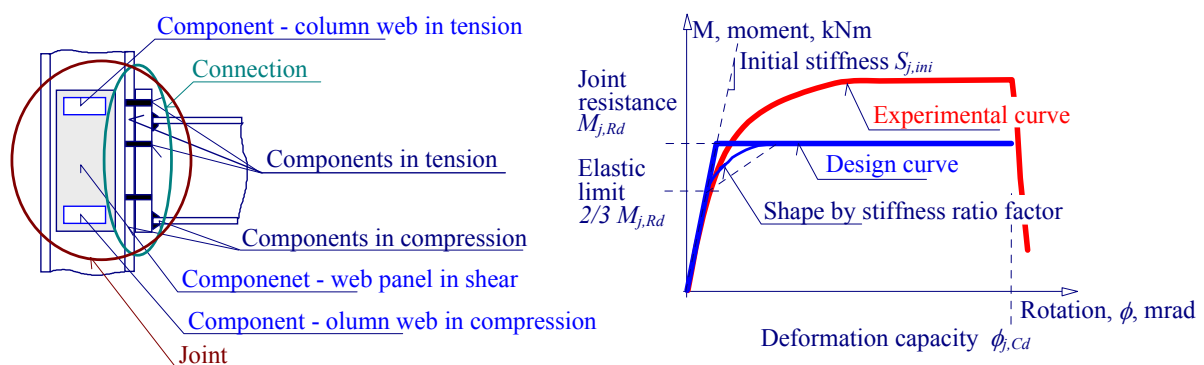

Figure 6.2 Basic components of a beam to column joint and the resulting moment – rotational diagram

The required deformation capacity (rotational capacity) of a joint depends on the type of the structure (e.g. statically determined or statically indeterminate) and the method of global analysis for the whole structure (elastic or plastic), but seldom this exceeds 60 mrad , see Figure 6.3.

The determination of the rotational capacity is qualitative. In prEN1993-1-8, deemed to satisfy rules are given, e.g. if yielding of the column flange or end plate in bending or the column web panel in shear governs the strength, then it is assumed that sufficient rotational capacity is provided. The prediction of the available rotational capacity by the component method, based on the deformation capacity of each component, is under development.

The column flange and the end plate in bending and the column web panel in shear are ductile components. The bolts in tension and shear and welds are typical examples of brittle components. Therefore, both modes of failure should not govern the strength of the connection. Such design will lead to brittle connections and potentially unsafe structures.

In the evaluation of the rotational capacity, it is necessary to consider possible unfavourable differences between the calculated strength and the actual strength of the component that is to provide the rotational capacity.

Such deviations may be caused by a higher actual yield strength of the component material or a difference in the actual dimensions or due to the calculation model underestimating the actual strength. Therefore, in the analysis of the rotational capacity, the upper limit of the resistance of the component to provide the rotational capacity, needs to be taken (for the calculation of the moment resistance $M_{j,Rd}$, the lower limit must be taken).

The rules to assure adequate rotational capacity for bolted and welded connections are included in prEN 1993-1-8 as “deem to satisfy” criteria, e.g. the rules to limit brittle failure caused by rupture of the bolts (mode 2 – bolt failure and plastic hinge in the plate, mode 3 – bolt failure) and weld failure.

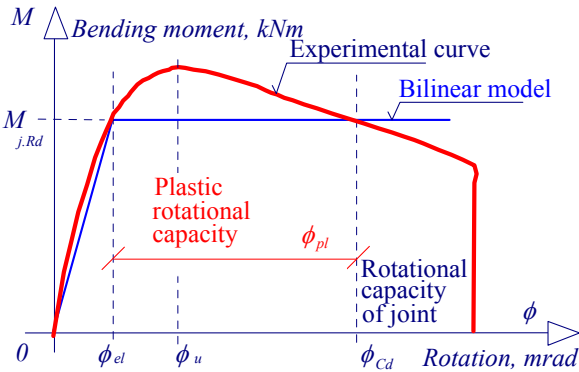

Figure 6.3 Rotational capacity, design limit of resistance by brittle collapse of the second bolt row of a beam to column end plate connection

Q&A 6.1 Stiffness Modification Coefficient η for End-Plate Connections

The values of the stiffness modification coefficient η given in prEN 1993-1-8 Table 5.2 do not cover the full range of different end-plate connections that can be used. For example, do the values allow for connections into the web of a column/beam, thin end plates vs. thick end plates, extended vs. flush end-plates etc.? Please provide the background to this table.

To make an elastic global analysis according to clause 5.1.2, you may take into account a stiffness, which is assumed to be the initial stiffness divided by the stiffness modification coefficient η , see Figure 6.4. The coefficient η is given in prEN 1993-1-8 Table 5.2.

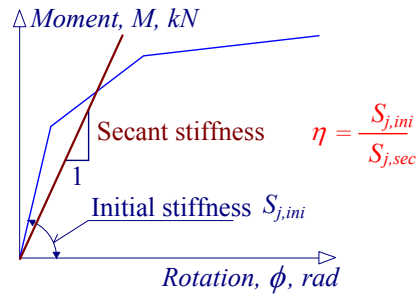
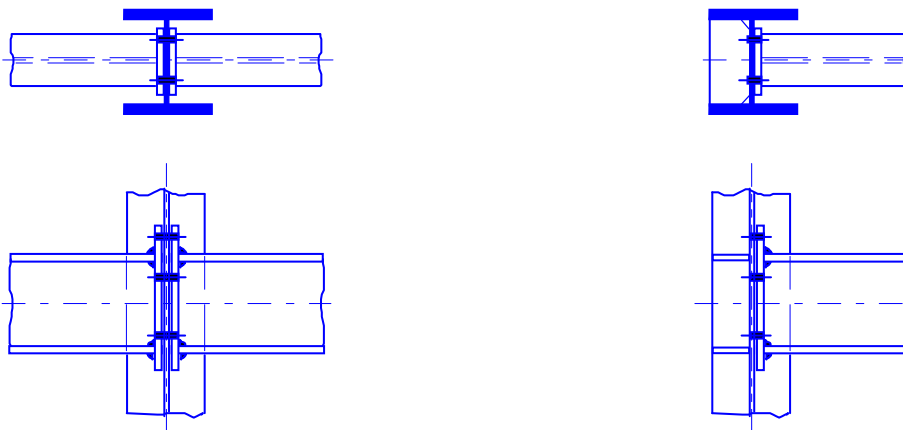

Figure 6.4 Stiffness for global elastic analysis

The thickness of the end plates influences the initial stiffness of the connection but not the stiffness modification coefficient η .

- For beams connected to the web of an unstiffened column or beam, the stiffness modification coefficient η is not relevant and these joints may be considered as hinges, see [Gomes, Jaspert, 1994] and [Gomes et al, 1994], for simplicity.
- For a continuous beam connected on both sides of the column web, see Figure 6.5a, the connection can be considered as a ‘beam splice’ with longer bolts.
- If the beam is connected to a stiffened column web, see Figure 6.5b, the stiffeners between the column flanges create a similar effect as a connection to the column flange.



a) beam splice

b) beam to stiffened column web

Figure 6.5 Beam to column minor axis joints

Q&A 6.2 Effective Length of Stiffened T-stub

Could you give the background information for the α curves used to calculate the effective length of a T-stub and equations for α and its dependence on λ_1 and λ_2 ?

The background to these rules is a mechanical model based on yield line theory. Details are given in a TU-Delft report written by Zoetemeijer [Zoetemeijer, 1990]. (Note the α values in figure 2.12 of the Zoetemeijer's publication need to be divided by 2 to compare with those given in the Eurocode).

The parallel parts of the curves in Figure 6.12 of prEN 1993-1-8 correspond to the basic equations in table 6.6. With the values of m_1 , m_2 and e , the values for λ_1 and λ_2 can be determined which give the value of α . The parallel parts of the curves $L_{eff} = \alpha m_1$ correspond to the basic equation: $L_{eff} = 4 m_1 + 1,25 e$. In the study by Zoetemeijer, the value of α did not exceed 2π . The curves for $\alpha = 7$ and 8 are added in prEN 1993-1-8, see Figure 6.6. The curves for a constant value α as illustrated in Figure 6.6, are given by the following equations:

$$\text{in case } \lambda_2 < \lambda_2^*: \lambda_1 = \lambda_1^* + (1 - \lambda_1^*) \left(\frac{\lambda_2^* - \lambda_2}{\lambda_2^*} \right)^{\frac{\alpha}{\sqrt{2}}} \quad (6.1)$$

$$\text{in case } \lambda_2 \geq \lambda_2^*: \lambda_1 = \lambda_1^* \quad (6.2)$$

where

$$\lambda_1^* = \frac{1,25}{\alpha - 2,75}, \quad (6.3)$$

$$\lambda_2^* = \frac{\alpha \lambda_1^*}{2}. \quad (6.4)$$

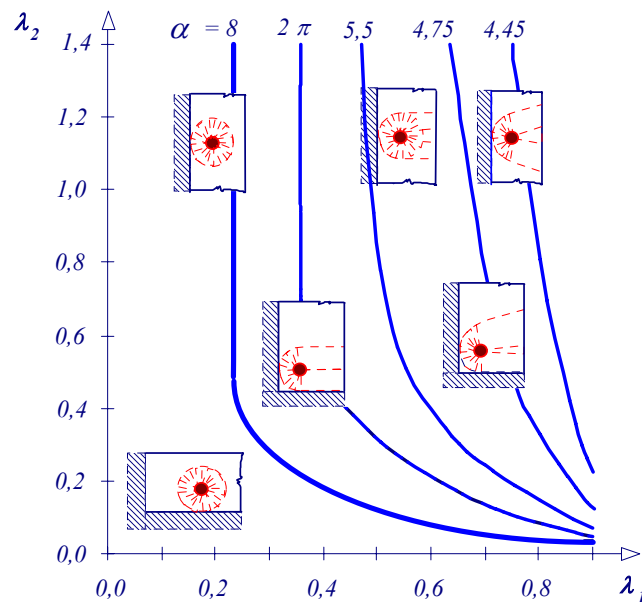

Figure 6.6 Values of α for stiffened column flanges and end plates

Q&A 6.3 Haunched Connections

The current version of prEN 1993-1-8 does not contain rules of the design of portal frame haunched connections. Could you recommend simple and safe rules or give a reference?

Two basic types can be distinguished: haunches designed to economise the rafter (inclination of about 10%) and haunches used to increase the bending moment resistance of the connection (by about 35%-40%). Similar questions arise in case of tapered built-up members. The component method in prEN 1993-1-8 can be used for all joints that can be decomposed into a set of basic components. This method can also be used for haunched connections.

There are two questions related to the component description and assembly of components in the case of haunched connections: the influence of the inclination of the beam on the internal forces and resistance of the beam flange and column web in compression, see Figure 6.7. The inclination needs to be taken into account for the evaluation of the component properties of the column web in compression and the end plate in bending (for welded connections, also of the column flange in bending and the column web in tension).

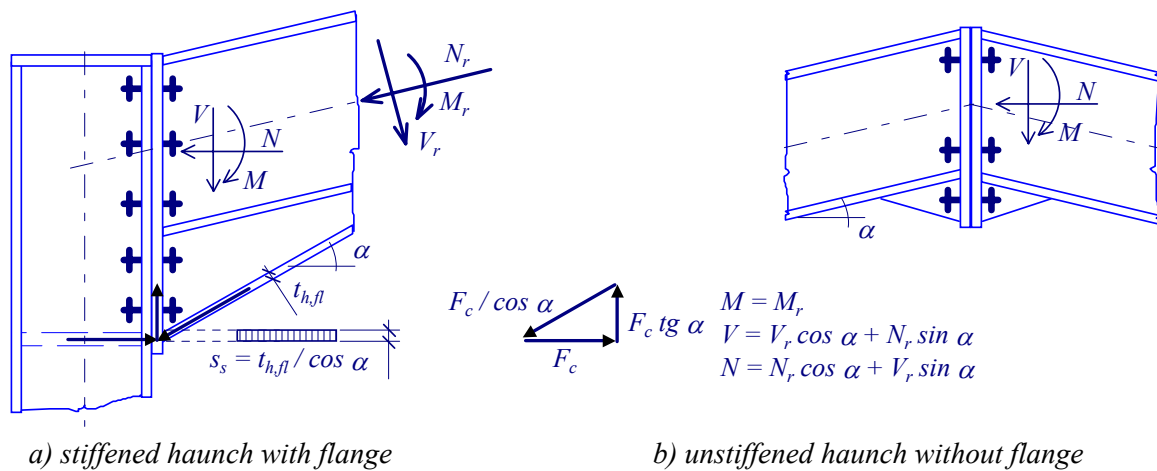

Figure 6.7 Typical haunched joints in portal frame

Precise details about haunches are given in Clause 6.2.4.7 of prEN 1993-1-8. If the height of the beam including the haunch exceeds 600 mm, the contribution of the beam web to the compression resistance should be limited to 20%. Reinforcing haunches should be arranged with the following restrictions: the steel grade should match that of the member; the flange size and web thickness of the haunch should not be less than that of the member; the angle of the haunch flange to the flange of the member should not be greater than 45°; and the length of the stiff bearing s_s should be taken as equal to the thickness of the haunch flange parallel to the beam, see Figure 6.7.

Q&A 6.4 Diagonal and K-stiffeners

Does it matter whether a (diagonal) stiffener of a beam-to-column joint is loaded in tension or in compression?

There is a difference in the resistance calculation of the stiffener. For a stiffener loaded in tension, the cross section resistance should be checked. For stiffeners loaded in compression, plate-buckling verification is required, see Figure 6.8. As a simplification, it is possible to use the following rules:

- The plate thickness of the stiffener should be the same size as the flange of the beam.
- The b/t ratio of the stiffener should be at least a class 3 cross section.

K-stiffeners are loaded in tension and in compression. Both aspects have to be checked as described above.

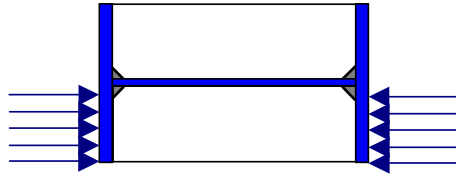

Figure 6.8 Plate buckling design of a web stiffener

Q&A 6.5 Yield line Patterns for End Plate Connection with Four Bolts in a Row

Can the method given in prEN 1993-1-8 be used for end plate connections with four bolts in a row?

The bolts a1-a4 and b1-b4 near the beam flange under tension can be taken for the bending moment resistance calculation, see Figure 6.9a. The bolts c2 and c3 could also be considered. However, the bolts c1 and c4 cannot be considered for the transfer of tension due to the limited stiffness of the end plate. These bolts together with the bolt row d can be used to transfer the applied shear forces.

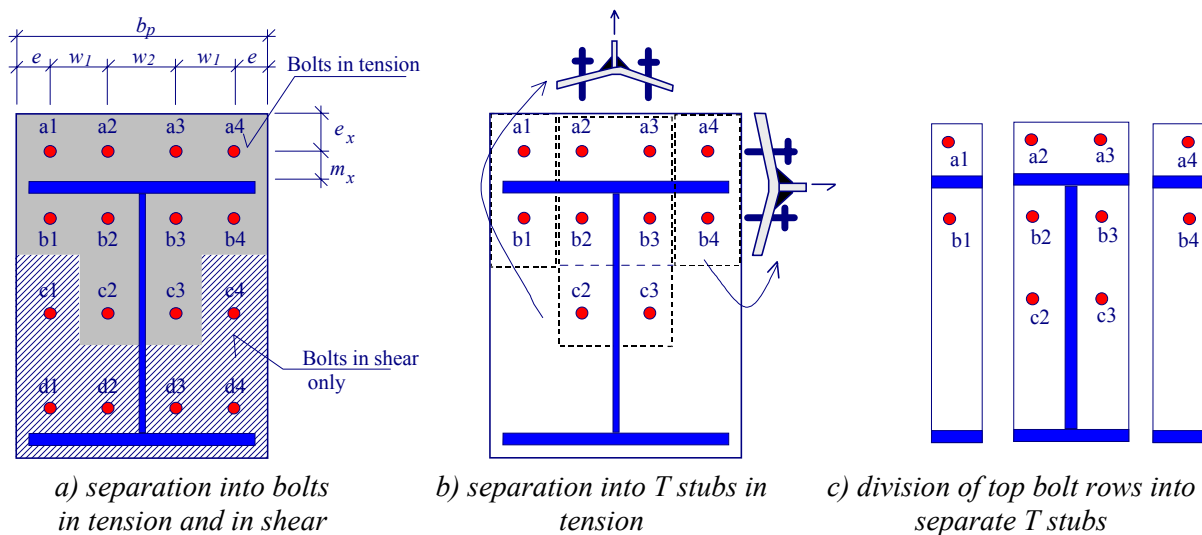

Figure 6.9 End-plate with 4 bolts in a row

Depending on the size of the end plate and bolt spacing, there are several possibilities for yield line patterns for the bolts in rows a and b. The most likely pattern for the extended part of the end plate (bolt row a) is given in Figure 6.10. Also bolts b1 and b4 are assumed to develop the same yield line pattern.

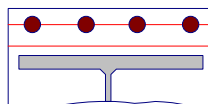

Figure 6.10 Assumed yield line pattern in the extended part of the end plate.

The logical approach using the T-stub schematisation is to divide the connection into T stubs as given in Figure 6.9c. For each T-stub, the effective length based on the yield line patterns given in prEN 1993-1-8, should be checked. Finally, the usual assembly of components can be applied to determine the bending moment resistance of the connection.

Q&A 6.6 Distribution of Forces in a Thick End Plate Connection

Is it permitted to use a plastic distribution of internal forces for a partial strength beam-to-column connection if very thick end plates are used? If not, are there any criteria for the thickness that is required for the elastic design?

The ratio of the strength of the end plate (column flange) to the strength of the bolts governs the collapse mode. PrEN 1993-1-8 gives the following three collapse modes:

- Mode 1: Yielding of the end plate or column flange (4 plastic hinges in T-stub). This occurs if the bolts are strong compared to the strength of the end plate or column flange.
- Mode 2: Bolt failure after partly yielding of the end plate or column flange (2 plastic hinges in T-stub). This occurs if the bolts are weak compared to the strength of the end plate or column flange.
- Mode 3: Bolt failure without yielding of the end plate or column flange. This occurs if strong end plates or column flanges are applied and relatively weak bolts.

Because of the differences in the deformation capacity between bolt failure and plate yielding by bending, Mode 1 is ductile and Mode 3 is brittle (no rotation capacity), see Fig 6.2.2 and tab. 6.2 of prEN 1993-1-8.

Following the procedure given in prEN 1993-1-8, the designer will be warned if his design results in Mode 3. This brittle mode of failure is usually not allowed because the rules for having sufficient rotational capacity of the joint are not fulfilled.

However, if the moment capacity of the joint is designed to carry 1,2 times the moment capacity of the connected beam, the necessary rotational capacity may be assumed to be supplied by the formation of a plastic hinge in the beam.

The rotational capacity of the joint depends on the deformation capacity of the end plate as well as that of the column flange, see Figure 6.11. If the column flange is thin, it will deform and provide sufficient rotational capacity, see Figure 6.11c.

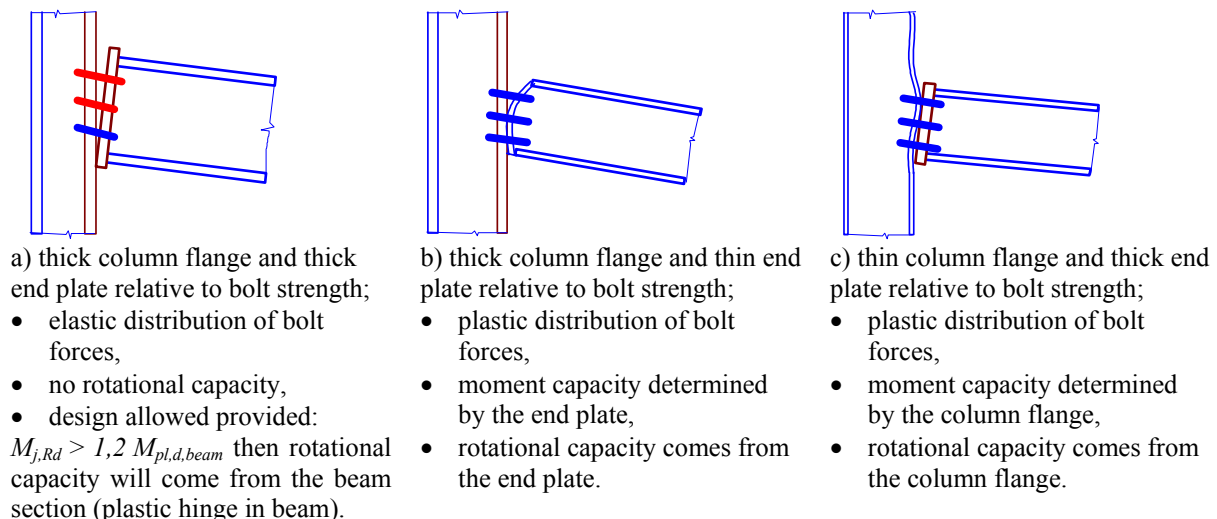

Figure 6.11 Influence of column flange thickness and end plate thickness on rotational capacity of the joint

Q&A 6.7 Distribution of Shear Forces in a Bolted Connection

An end-plate connection is usually loaded by a moment and a shear force. How is the shear force distributed over the bolts?

Any distribution of shear force between the bolts is allowed, provided that the conditions for equilibrium and deformation capacity (ductility) are fulfilled. It is allowed to distribute the shear force equally over all bolts, see Figure 6.12. The bolts loaded in tension and shear should be checked using the following rules for combined tension and shear, see prEN 1993-1-8,

$$\frac{F_{v,Sd}}{F_{v,Rd}} + \frac{F_{t,Rd}}{1,4 F_{t,Rd}} \leq 1,0 . \quad (6.5)$$

In general, however, the shear force is distributed over the bolts in the compression part of the joint. The number of bolts needed equals the shear force divided by the shear capacity of each bolt. The other bolts can be designed for tension only (in the tension zone).

Furthermore, to get sufficient deformation capacity, it is important that the capacity of the bolts in shear is higher than the bearing capacity of the bolts in the end plate or the column flange.

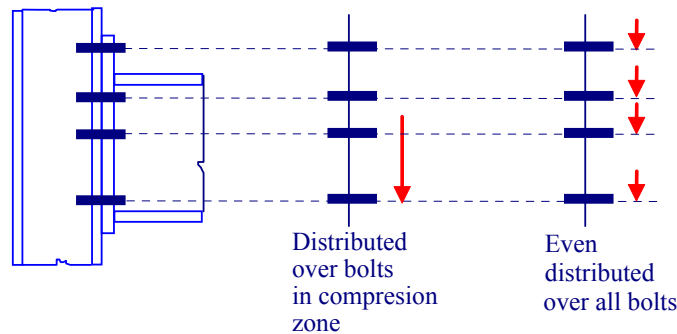

Figure 6.12 Example of distribution of shear forces in an end plate connection

Q&A 6.8 Prying Force of T-stub in Fatigue Design

The effect of prying of bolts is included in the formulae for the resistance of bolt rows. However, in the case of fatigue, the effect of prying forces in the bolts should be known in order to verify the bolts. How is this done?

In the case of fatigue, bolts should always be pre-tensioned. Transfer of the varying loads should pass directly through a stiff contact surface and not via the bolts. This is illustrated in Figure 6.13 and Figure 6.14.

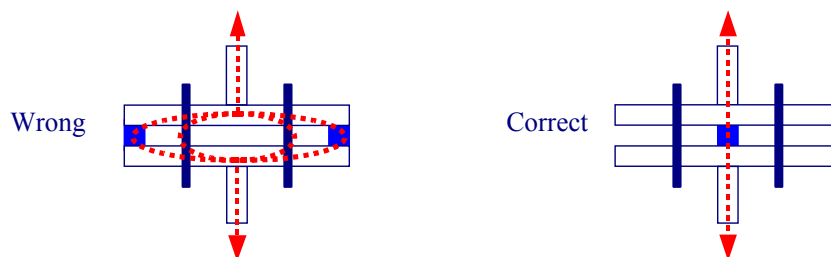

Figure 6.13 Wrong and correct detailing of a pre-tensioned joint; the flow of the varying force through the joint is illustrated by dotted lines

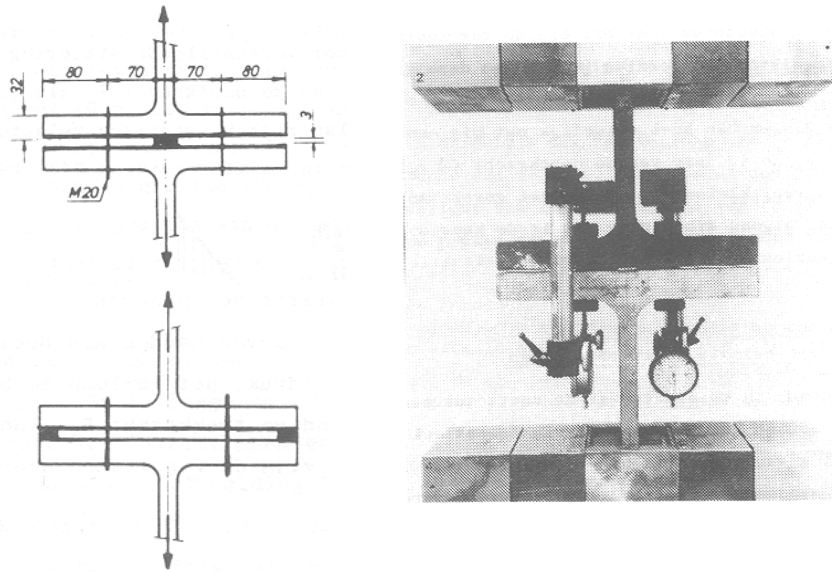

Figure 6.14 Test specimens and assembling of a T-stub

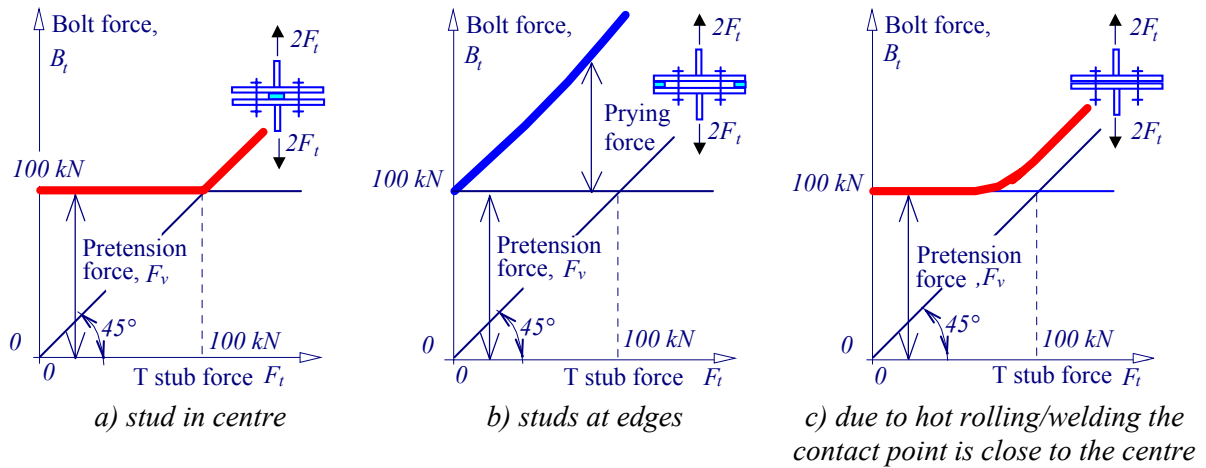

Figure 6.15 Test results of a T-stub, force in bolts F_b , T-stub force F_t

In general, the force distribution through the joint is via the stiffest route. The force in bolt F_b can be divided into a contact force F_c and a tensile force F_t . In all three cases the joint has been pre-stressed with a force F_v . By introducing an external tensile force $2F_t$ in test set-up a) the contact force will be reduced by a force equal to F_t . As long as F_t is less than F_v , no cyclic load effect will occur in the bolt. In the test set-up as indicated in b) the contact force does not change when an external force is applied. This means that all cyclic load effects will appear in the bolt. Set-up c) shows the behaviour when two flanges are connected without a contact plate but with a contact area near the web due to the deformation of the plate caused by hot rolling or by the process of welding the end plate.

Q&A 6.9 Joints Loaded by Bending Moment and Axial Force

What approach should be used to design a haunched connection, which is loaded by axial force and bending moment?

There are two parts in this question, which will be discussed separately: What is the influence of an inclination of the beam on the design of the joint? What is the influence of an axial load on the moment resistance of a joint?

The rules in prEN 1993-1-8 only apply when the forces have been resolved in to their horizontal (parallel) and vertical (perpendicular) components. The inclination of the beam causes the geometry of the joint to change. The increase in level arm as a result of the inclination of the beam should be taken into account.

The moment resistance of a joint loaded with an axial load can be determined from a linear interaction line between M_{Sd} and N_{Sd} , as shown in Figure 6.16. The linear interaction line is found by determining the extreme values of the moment resistance (M_{Rd}) with no axial load and the axial load resistance (N_{Rd}) without bending moment. The design resistance of the joint should be checked using the following equation

$$\frac{N_{Sd}}{N_{Rd}} + \frac{M_{Sd}}{M_{Rd}} \leq 1. \quad (6.6)$$

In some cases this is a conservative approach, especially for non-symmetrical joints. An alternative approach was developed, e.g. see [Jaspart et al, 1999], [Sokol et al, 2002]. In Figure 6.16 the point ① represents the maximum bending resistance; ② bending resistance in case of zero axial force; ③ maximum resistance in compression; ④ resistance in compression in case of zero bending moment; ⑤ negative bending in case of zero axial force; ⑥ maximum negative bending resistance; ⑦ point of activation of second bolt row; ⑧ resistance in axial tension; ⑨ point of activation of second bolt row.

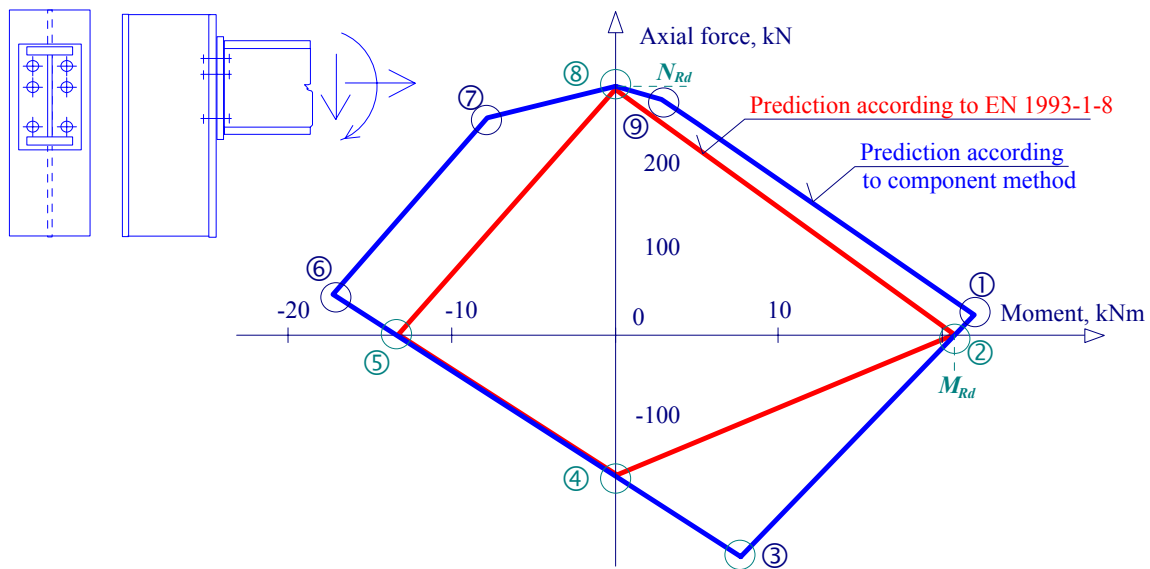

Figure 6.16 Moment – axial load interaction curve, prediction according to prEN 1993-1-8 is marked by dotted line; the component method is marked as a solid line

This approach is based on an extension of the component method used for base plates in prEN 1993-1-8. Properties of the components should be evaluated in the same way as for joints without axial force and are used in a modified assembly procedure to calculate the resistance and stiffness of the joint [Sokol et al, 2002].

Two typical loading paths may be distinguished, see Figure 6.17. In the case of non-proportional loading, the normal force is applied to the end plate connection in the first step, followed

by application of the moment. In the case of proportional loading, the normal force and the bending moment are applied simultaneously at a constant ratio between the moment and normal force. In the case of non-proportional loading, the initial stiffness of the joint is higher than for non-proportional loading. This effect is caused by the presence of the normal force, which keeps the end plate in contact with the column flange at low bending moments. Therefore only the components in compression contribute to the deformation of the joint.

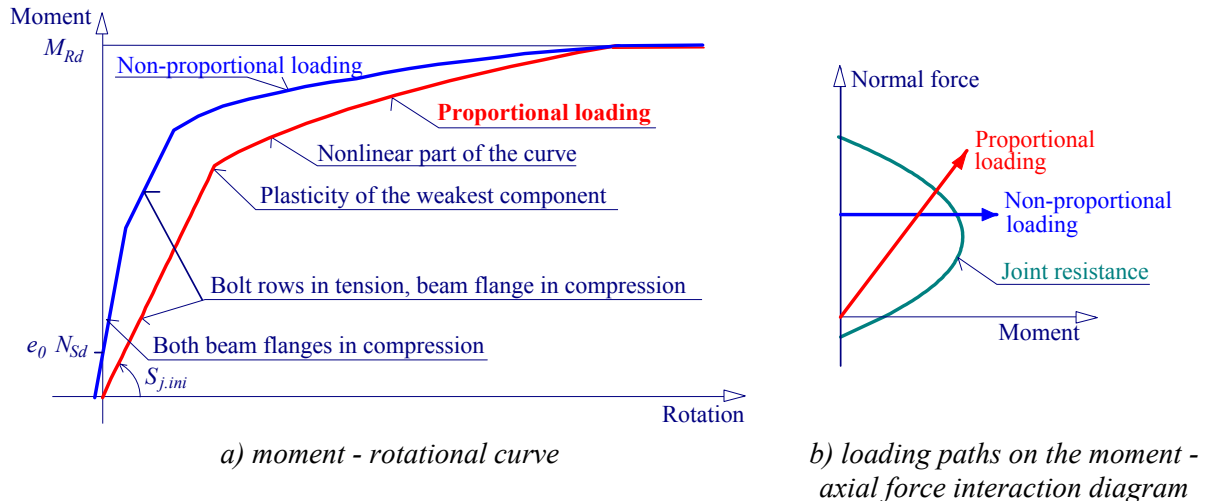

Figure 6.17 Proportional and non-proportional loading

The size and shape of the contact area between the end plate and the column flange are based on the effective rigid area [Wald, 1995]. The position of the neutral axis can be evaluated from equilibrium equations, taking into account the resistance of the tension and compression parts $F_{t,Rd}$ and $F_{c,Rd}$ respectively, and the applied normal force N_{Sd} and bending moment M_{Sd} . Plastic distribution of internal forces is assumed for the calculation, see Figure 6.18.

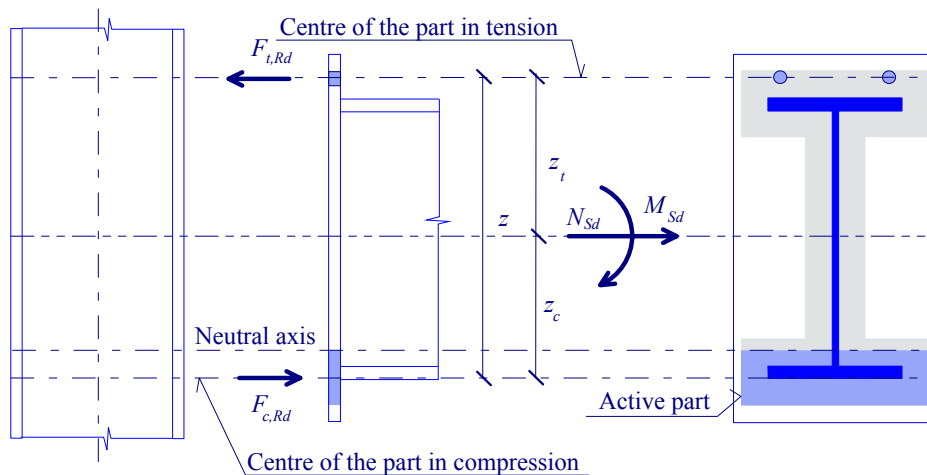

Figure 6.18 The equilibrium in the joint

The simplified model takes into account only the effective area at beam flanges [Steenhuis, 1998] and the effective area of the beam web is neglected, as shown in Figure 6.19. It is assumed that the compression force acts at the centre of the compression flange. The tension force is located in the bolt row in tension. In the case of two or more bolt rows in the tension part, the resistance of the part in tension is obtained as the resulting force of the active bolt rows.

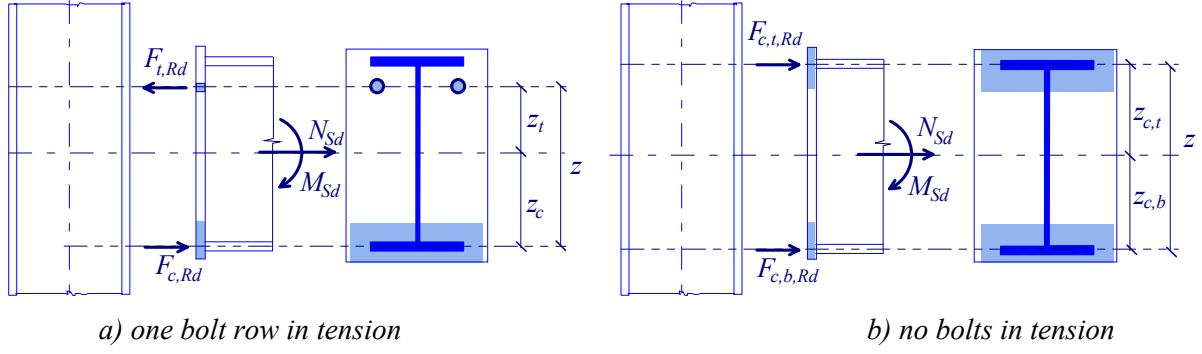

Figure 6.19 The simplified model with the effective area at the flanges only

The forces represent resistances of the components in tension $F_{t,Rd}$, and in compression $F_{c,t,Rd}$, $F_{c,b,Rd}$. For simplicity, the model will be derived for proportional loading only. Using equilibrium equations, the following equations may be derived from Figure 6.20a assuming the eccentricity $e = M_{Sd}/N_{Sd} \leq -z_c$.

$$\frac{M_{Sd}}{z} + \frac{N_{Sd} z_c}{z} \leq F_t \quad (6.6)$$

and

$$\frac{M_{Sd}}{z} - \frac{N_{Sd} z_t}{z} \leq -F_c. \quad (6.7)$$

Since the eccentricity $e = \frac{M_{Sd}}{N_{Sd}} = \frac{M_{Rd}}{N_{Rd}} = \text{const}$ for proportional loading, equations (6.6) and (6.7) may be rearranged to

$$M_{j,Rd} = \min \left\{ \begin{array}{l} \frac{F_{t,Rd} z}{\frac{z_c}{e} + 1} \\ \frac{F_{c,Rd} z}{1 - \frac{z_{t,l}}{e}} \end{array} \right\}. \quad (6.8)$$

When the eccentricity $e = M_{Sd}/N_{Sd} \geq -z_c$, see Figure 6.20b, there is no tension force in the bolt row, but both parts of the connection are loaded in compression. In this case, equation (6.8) needs to be modified to give

$$M_{j,Rd} = \min \left\{ \begin{array}{l} \frac{-F_{c,t,Rd} z}{\frac{z_{c,b}}{e} + 1} \\ \frac{-F_{c,b,Rd} z}{\frac{z_{c,t}}{e} - 1} \end{array} \right\}. \quad (6.9)$$

The rotational stiffness of the connection is based on the deformation of the components.

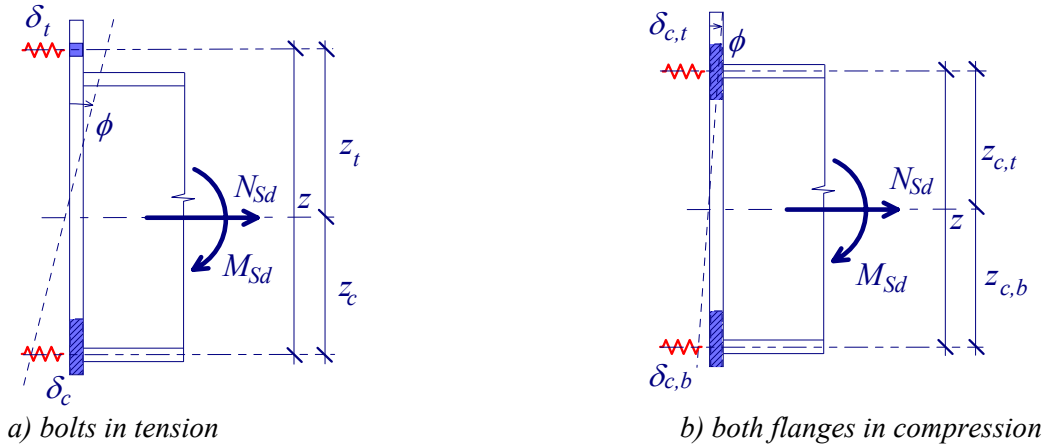

Figure 6.20 Mechanical model of the end plate

The elastic deformation of the components in tension and compression parts, see Figure 6.20a, may be expressed as

$$\delta_t = \frac{\frac{M_{Sd}}{z} + \frac{N_{Sd} z_c}{z}}{E k_t} = \frac{M_{Sd} + N_{Sd} z_c}{E z k_t}, \quad (6.10)$$

$$\delta_c = \frac{\frac{M_{Sd}}{z} - \frac{N_{Sd} z_t}{z}}{E k_{c,r}} = \frac{M_{Sd} - N_{Sd} z_t}{E z k_c}, \quad (6.11)$$

and the joint rotation is calculated as follows using the deformation of these components

$$\phi = \frac{\delta_t + \delta_c}{z} = \frac{I}{E z^2} \left(\frac{M_{Sd} + N_{Sd} z_c}{k_t} + \frac{M_{Sd} - N_{Sd} z_t}{k_c} \right). \quad (6.12)$$

The rotational stiffness of the joint depends on the bending moment, which is induced by the normal force applied with constant eccentricity e

$$S_{j.ini} = \frac{M_{Sd}}{\phi}. \quad (6.13)$$

The stiffness is derived by substitution of the rotation of the joint (6.12) into equation (6.13)

$$S_{j.ini} = \frac{M_{Sd}}{M_{Sd} + N_{Sd} e_0} \frac{E z^2}{\left(\frac{I}{k_c} + \frac{I}{k_t} \right)} = \frac{e}{e + e_0} \frac{E z^2}{\sum \frac{I}{k}}, \quad (6.14)$$

where the eccentricity e_0 is defined as follows

$$e_0 = \frac{z_c k_c - z_t k_t}{k_c + k_t}. \quad (6.15)$$

The non-linear part of the moment-rotation curve may be modelled by introducing the stiffness ratio μ , which depends on the ratio γ of the acting forces and their capacities

$$\mu = (1,5 \gamma)^{2,7} \geq 1. \quad (6.16)$$

Assuming the lever arms z_t and z_c of the components are approximately equal to $h/2$, i.e. one half of the height of the connected beam, the factor γ can be defined as

$$\gamma = \frac{M_{Sd} + 0,5 h N_{Sd}}{M_{Rd} + 0,5 h N_{Rd}}, \quad (6.17)$$

and by substituting for the eccentricity e , this can be simplified to

$$\gamma = \frac{e + \frac{h}{2}}{\left(\frac{M_{Rd}}{M_{Sd}}\right) e + \frac{h}{2}}. \quad (6.18)$$

Using the factor μ the moment-rotation curve of a joint, which subject to proportional loading, may be expressed by following equation

$$S_j = \frac{e}{e + e_0} \frac{E z^2}{\mu \sum \frac{I}{k}}. \quad (6.19)$$

Q&A 6.10 Stiffening of the Column Web Panel with a Morris Stiffener

Can the general rules for transverse stiffeners given in prEN 1993-1-8 be applied to Morris stiffeners?

When the resistance of the web is inadequate, web plates, diagonal or "K" stiffeners can be used to increase its capacity. However, the Morris shear stiffener has been developed to resolve two problems simultaneously – the shear capacity of the column web and the distortion of the column flange.

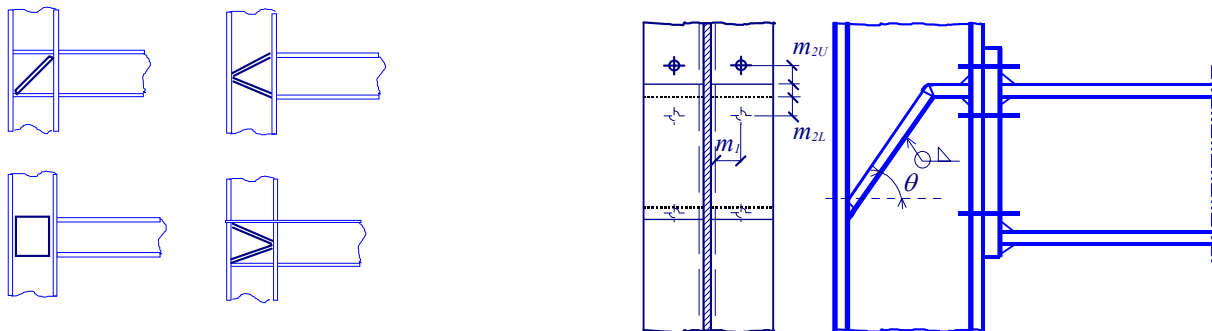

a) diagonal stiffener, web plate, K stiffeners

b) Morris shear stiffener

Figure 6.21 Shear stiffener of column web

Tests have been carried out to compare the Morris stiffening arrangement with traditional ways of stiffening and the experimental results show that the Morris shear stiffener is structurally efficient. It has better initial stiffness and post-yield performance when compared to 'K' stiffeners. Furthermore, it is economic to manufacture and it overcomes the difficulties of bolt access associated with the other stiffeners. It is particularly effective for use with UB sections used as columns, but it is difficult to accommodate in smaller UC sizes. The horizontal portion carries the same forces as

a tension stiffener at the same location. The length should be sufficient to provide for bolt access (about 100 mm). The diagonal portion should be designed as a diagonal stiffener as follows: The area of the stiffeners $A_{sg} = 2 b_{sg} t_s$ is given for the thickness of the stiffener t_s and the width of the stiffener on each side b_{sg} by

$$A_{sg} \geq \frac{F_v - F_{v,w,Rd}}{f_{yd} \cos \theta}, \quad (6.20)$$

where F_v is the applied shear force, $F_{v,w,Rd}$ is the resistance of the unstiffened column web panel, f_{yd} is the lower design strength of stiffener or column and θ is the angle of the stiffener from the horizontal.

The welds connecting the diagonal stiffeners to the column flange should be fill-in welds with a sealing run providing a combined throat thickness equal to the thickness of the stiffener. Welds connecting the horizontal part of the Morris stiffener to the column flange should be designed to provide a net throat thickness equal to $A_{sn} = 2 b_{sn} t_s$ given by

$$A_{sn} \geq \frac{m_l}{f_{yd}} \left(\frac{F_{ri}}{m_l + m_{2L}} + \frac{F_{rj}}{m_l + m_{2U}} \right), \quad (6.21)$$

where m_l is the distance from the centre of the bolt to the root radius, m_{2L} is the distance from the edge of the stiffener to the centre of the lower bolt row, m_{2U} is the distance from the edge of the stiffener to the centre of the upper bolt row, F_{ri} is the tension force in the upper bolt row, F_{rj} is the tension force in the lower bolt row and f_{yd} is the design strength of the stiffener or the column (the lesser of the two).

7 COLUMN BASES

A column base consists of a column, a base plate and an anchoring assembly. In general they are designed with unstiffened base plates, but stiffened base plates may be used where the connection is required to transfer high bending moments. The column base is usually supported by either a concrete slab or a sub-structure (e.g. a piled foundation).

prEN 1993-1-8: 2003 includes rules for calculating the strength and stiffness of column bases. The procedure is applicable to columns of both open and closed cross sections [Wald et al, 2000]. Further column base details may also be adopted, including base plates strengthened by adding steel elements and embedding the lower portion of the column into a pocket in the concrete foundation. The influence of the support of the concrete foundation, which may be considerable in certain ground conditions, is not covered in prEN 1993-1-8: 2003.

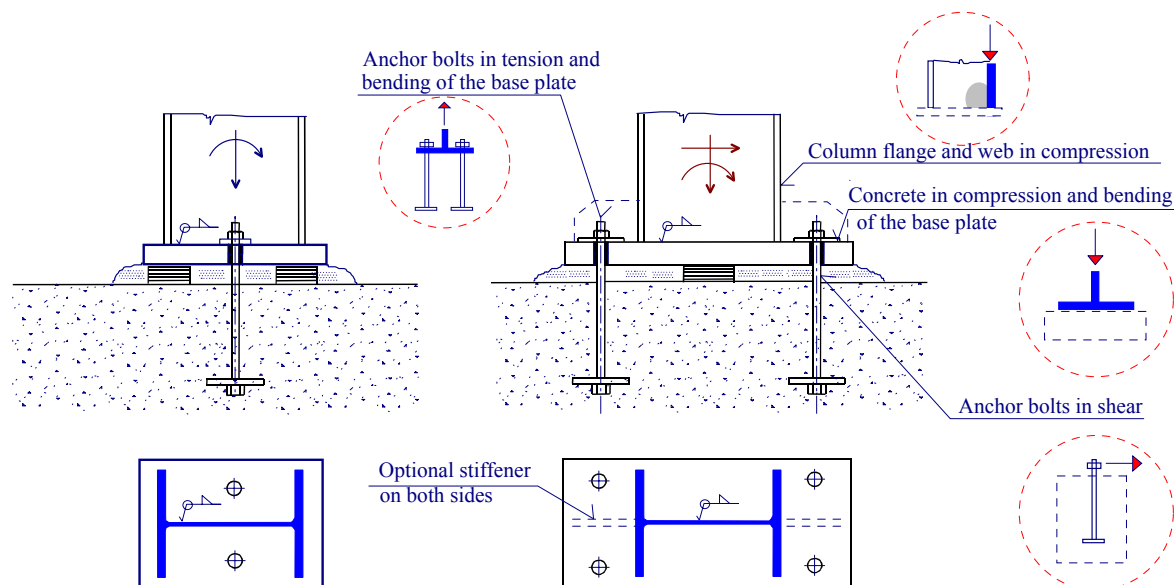

a) bolts inside the base plate

b) bolts outside the base plate (with optional stiffener)

Figure 7.1 Typical column base assembly and the selection of components

The traditional approach for the design of pinned bases results in a base plate thickness of sufficient stiffness to ensure a uniform stress under the base plate and therefore the base plate can be modelled as a rigid plate [DeWolf, 1978]. The traditional design of moment-resisting column bases involves an elastic analysis based on the assumption that the sections remain plane. By solving equilibrium equations, the maximum stress in the concrete foundation (based on linear stress distribution) and the tension in the holding down assembly may be determined. Whilst this procedure has proved satisfactory in service over many years, the approach ignores the flexibility of the base plate in bending (even when it is strengthened by stiffeners), the holding down assemblies and the concrete [DeWolf, Ricker, 1990]. The concept, which was adopted in prEN 1993-1-8: transfers the flexible base plate into an effective rigid plate and allows stress in the concrete foundation equal to the resistance in concentrated compression [Murray, 1983]. A plastic distribution of the internal forces is used for calculations at the ultimate limit state.

The component method similar to method for beam-to-column joints is used for the calculation of stiffness [Wald, 1995]. The component approach involves identifying the important parts of the connection, see Figure 7.1 [Wald et al, 1998], called components, and determining the strength and stiffness of each component. The components are assembled to produce a model of the complete arrangement.

The rules for resistance calculation of column bases are included in prEN 1993-1-8: 2003 Chapter 6.2.6 and rules for stiffness calculation are given in Chapter 6.3.4. Methods for transferring the horizontal shear forces are given in Chapter 6.2.1.2. Classification boundaries, see [Wald, Jaspart, 1999], for column base stiffness are included in Chapter 3.2.2.5.

Q&A 7.1 Elastic Resistance of a Base Plate

Why is the resistance of a base plate based on its elastic properties?

By limiting the deformations of the base plate to the elastic range a uniform stress under the base plate may be assumed, see Figure 7.2. It also ensures that the yield strength of the base plate is not exceeded. The effective bearing area of a flexible base plate is based on an effective width c .

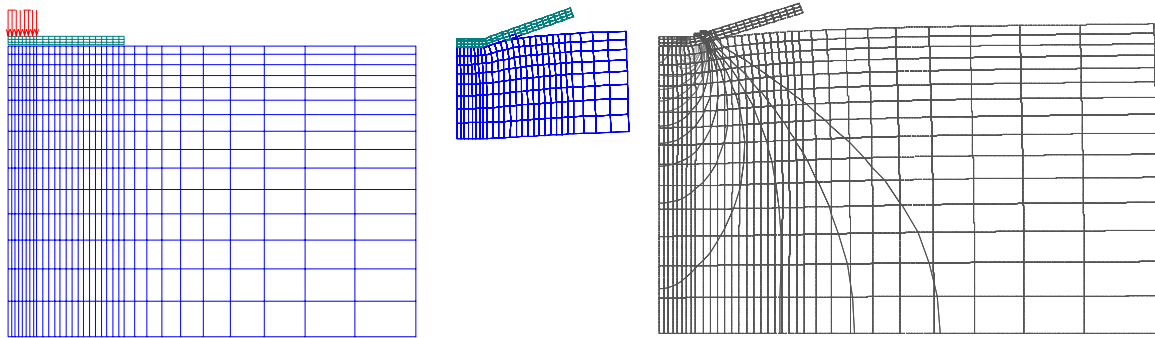

Figure 7.2 Finite element model of base plate T stub and concrete block in compression, undeformed and deformed mesh and the principal stress in concrete [Wald, Baniotopoulos, 1998]

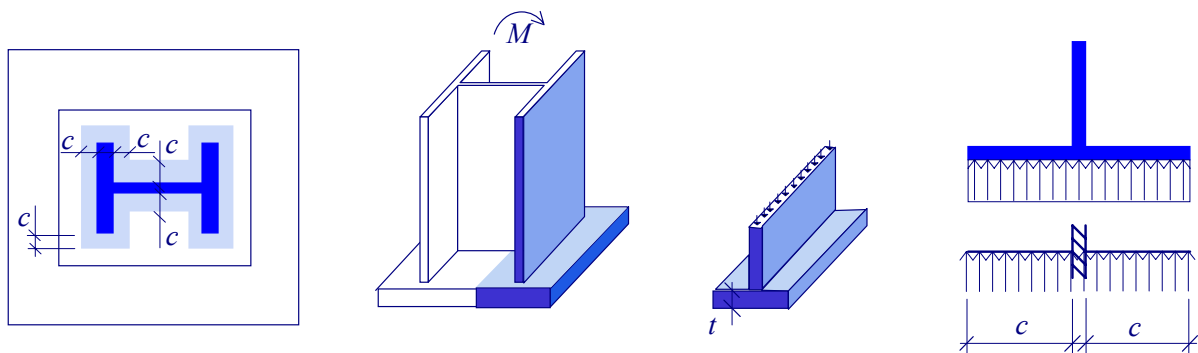

Figure 7.3 Engineering model of the base plate

The elastic bending moment resistance per unit length of the base plate should be taken as

$$M' = \frac{1}{6} t^2 f_{yd}, \quad (7.1)$$

and the bending moment per unit length [DeWolf, Sarrisley, 1980], acting on the base plate represented by a cantilever of span c , see Figure 7.3, is

$$M' = \frac{1}{2} f_j c^2, \quad (7.2)$$

where f_j is concrete bearing strength. When these moments are equal, the bending moment resistance of the base plate is reached and the formula for evaluating c can be obtained from

$$\frac{1}{2} f_j c^2 = \frac{1}{6} t^2 f_y \quad (7.3)$$

as

$$c = t \sqrt{\frac{f_y}{3 f_j \gamma_{M0}}}. \quad (7.4)$$

Q&A 7.2 Base Plate Resistance with Low Quality Grout

In prEN 1993-1-8, the joint coefficient β_j is taken as $2/3$ when the grout has at least 20% of the characteristic strength of the concrete foundation. What value should be taken when the strength of the grout is smaller?

The influence of low quality grout has been studied experimentally and numerically. It was found that the thin layer of grout does not affect the resistance of the concrete in bearing. It is expected that the grout layer is in three-dimensional compression, i.e. the grout between the concrete and the base plate, is similar to a liquid.

Most of the mortars have a higher resistance compared to the material of the concrete block [Stark, Bijlaard, 1988]. In such cases, the grout layer may be neglected. In other cases, the bearing resistance can be checked, assuming a distribution of normal stress under the effective plate at an angle of 45° , see Figure 7.4. Where the thickness of the grout is more than 50 mm , the characteristic strength of the grout should be at least the same as that of the concrete foundation [prEN 1993-1-8: 2003]. Further information is given in Q&A 0.3.

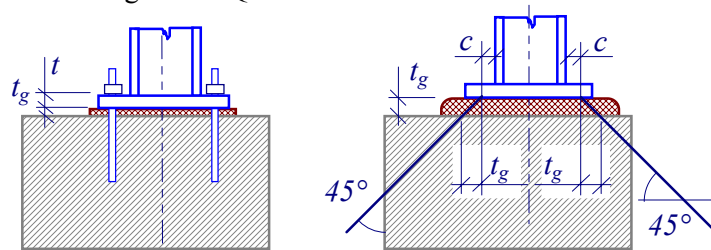

Figure 7.4 The stress distribution in the grout

Q&A 7.3 Comparison of Concrete Strength Calculation according to EC2 and EC3

It seems the results from calculating the bearing strength of a column base f_j are the same as those given in prEN 1992-1-1.

According to prEN 1992-1-1 the strength is

$$F_{Rdu} = A_{c0} f_{cd} \sqrt{\frac{A_{c1}}{A_{c0}}} \leq 3,3 A_{c0} f_{cd}$$

According to prEN 1993-1-8 the maximum value for k_j is $5,0$. For this value we get a value of

$$f_j = \frac{2}{3} \cdot 5 \cdot f_{cd} = 3,33 f_{cd}$$

The result is the same as given in prEN 1992-1-1, however the methods are different. Is there any background information on this?

PrEN 1993-1 – Design of concrete structures and prEN 1993-1 - Design of steel structures, solve the same problem of the bearing resistance of concrete loaded by a steel plate. The bearing resistance is limited by crushing of the concrete [Hawkins, 1968a,b]. The technical literature concerned with the bearing strength of the concrete block loaded through a plate may be treated in two broad categories. Firstly, investigations focused on the bearing stress of rigid plates, most of the research concerned pre-stressed tendons. Secondly, studies were focused on flexible plates loaded by the column cross section, resulting in transfer of the load only by a portion of the plate.

The experimental and analytical models include ratios of concrete strength to plate area, relative concrete depth, and location of the plate on the concrete foundation and the effects of reinforcement. The result of these studies on foundations with punch loading and fully loaded plates offers qualitative information on the behaviour of base plate foundations. Failure occurs when an inverted pyramid forms under the plate. The application of limit state analysis on concrete includes three-dimensional behaviour of materials, plasticization, and cracking. Experimental studies [Shelson,

1957; Hawkins, 1968, DeWolf, 1978] led to the development of an appropriate model for column base bearing stress, which has been adopted by current codes. A separate check on the concrete block is necessary to calculate shear resistance, bending and punching shear resistance of the concrete block according to the block geometry and detailing.

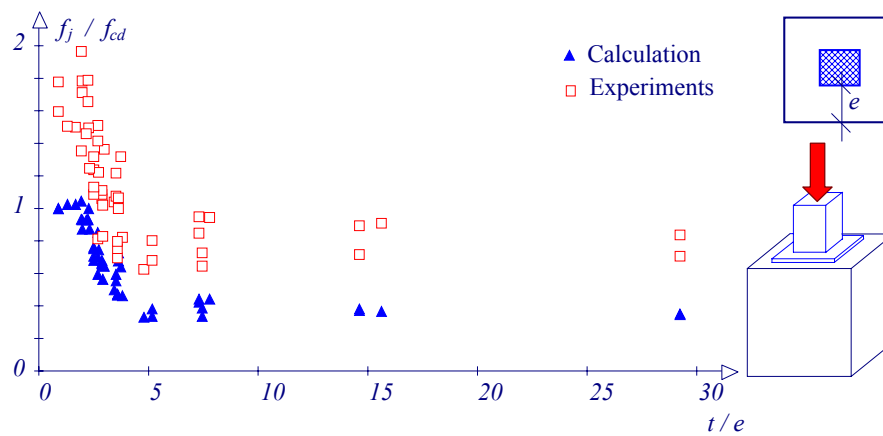

Figure 7.5 Relative bearing resistance - base plate slenderness relationship, calculation and experiments [DeWolf, 1978], [Hawkins, 1968a]

The influence of a flexible plate was solved by the introduction of the equivalent rigid plate [Stockwell, 1975]. This assumption reflects realistic non-uniform stress distribution with maximum pressure following the profile shape. The model is validated by tests. In total, 50 tests were examined to check the concrete bearing resistance [DeWolf, 1978; Hawkins, 1968a]. The size of the concrete block, the size and thickness of the steel plate and the concrete strength were the variables. The test specimens consist of a concrete cube of size from 150 to 330 mm with a centric load acting through a steel plate. Figure 7.5 shows the relationship between the slenderness of the base plate, expressed as a ratio of the base plate thickness to the edge distance, and the relative bearing resistance. The bearing capacity of test specimens at concrete failure is in the range from 1,4 to 2,5 times the capacity calculated according to prEN1993-1-8 with an average value of 1,75.

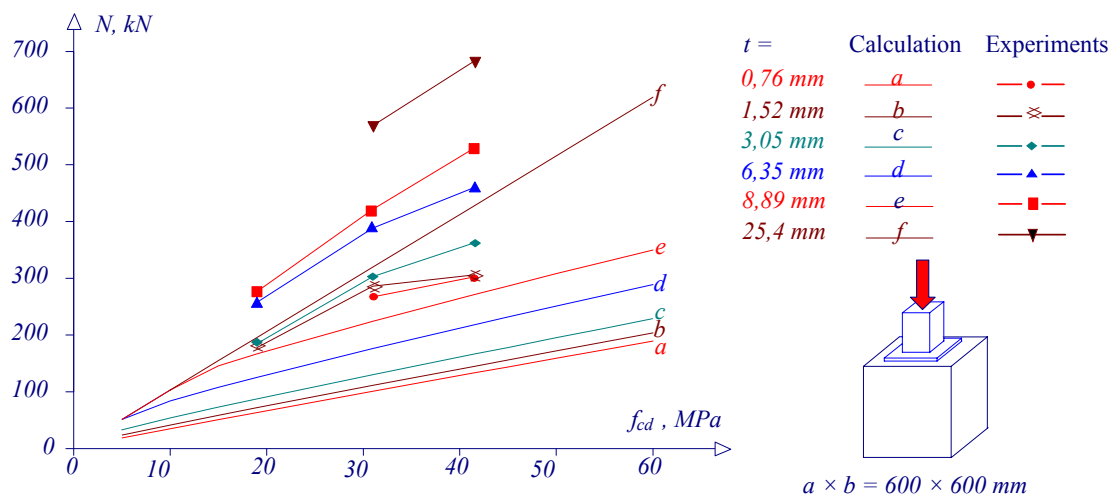

Figure 7.6 Concrete strength - ultimate load capacity relationship [Hawkins, 1968a]

This simple and practical method was modified and checked against the experimental results, [Bijlaard, 1982], [Murray, 1983]. It was also found [DeWolf and Sarisley, 1980] that the bearing stress increases with the eccentricity of the normal force. Where the distance from the plate edge to the block edge is fixed and the load eccentricity is increased, the contact area is reduced resulting in an increase of the bearing stress. In the case of crushing of the concrete surface under the rigid edge,

it is necessary to apply the theory of damage. This is not acceptable for practical design and determines the boundaries of the analysis described above.

The influence of the concrete strength is shown in Figure 7.6. 16 tests with similar geometry and material properties were selected from the experimental programme carried out by Hawkins [Hawkins, 1968a]. The only variable was the concrete strength and strengths of 19, 31 and 42 MPa were used.

Q&A 7.4 Stress Concentration under the Base Plate

Please, provide background documentation to justify using a value of f_j , which can lead to values of f_j more than 10 times higher than the characteristic strength of the grout. According to prEN 1993-1-8, the maximum value for k_j is 5,0 for a square base plate. For this maximum value we get the maximum value of $f_j = 2/3 * 5 * f_{cd} = 3,33 f_{cd}$. It is recommended to use a joint coefficient of $\beta_j = 2/3$, when the characteristic strength of the grout is not less than 0,2 times the characteristic strength of the concrete, therefore the lowest strength of the grout is $f_{cd,g} = 3,33 * f_{cd} / 0,2 = 16,66 f_{cd}$.

The resistance of the grout and the concrete block in compression is limited by crushing of the grout or concrete under a flexible base plate. In the engineering models used, the flexible base plate is replaced by an equivalent rigid plate. The equivalent plate is formed from the column cross-section increased by a strip of effective width c , see Figure 7.7 [prEN 1993-1-8: 2003]. The bearing resistance of the concrete foundation represents a 3D loading condition for the concrete. In this case, the experimental resistance was about 6,25 higher than compression resistance of the concrete. The calculation of the concrete bearing strength f_j is reflected in the standard prEN 1993-1-8 by use of a stress concentration factor k_j with a maximum value of 5,0 for a square base plate. The bearing resistance of the base plate $F_{c,Rd}$ is calculated from

$$a_1 = \min \left\{ \begin{array}{l} a + 2a_r \\ 5a \\ a + h \\ 5b_1 \end{array} \right\}, \quad a_1 \geq a, \quad (7.5a)$$

$$b_1 = \min \left\{ \begin{array}{l} b + 2b_r \\ 5b \\ b + h \\ 5a_1 \end{array} \right\}, \quad b_1 \geq b, \quad (7.5b)$$

$$k_j = \sqrt{\frac{a_1 b_1}{a b}}, \quad (7.6)$$

$$f_j = \frac{2}{3} \frac{k_j f_{ck}}{\gamma_c}, \quad (7.7)$$

$$c = t \sqrt{\frac{f_y}{3 f_j \gamma_{M0}}}, \quad (7.8)$$

$$F_{c,Rd} = A_{eff} f_j. \quad (7.9)$$

The effective area A_{eff} is described in Figure 7.7. The grout quality and thickness is introduced by the joint coefficient β_j . For $\beta_j = 2/3$, it is expected that the characteristic strength $f_{ck,g}$ of the grout is not

less than 0,2 times the characteristic strength of the concrete foundation f_{ck} ($f_{ck,g} \leq 0,2 f_{ck}$) and the thickness of the grout is $t_g \leq 0,2 \min(a; b)$. In the case of a lower quality or thicker layer of the grout, it is necessary to check the grout separately. This check should be carried out in the same way as for the resistance calculation for the concrete block.

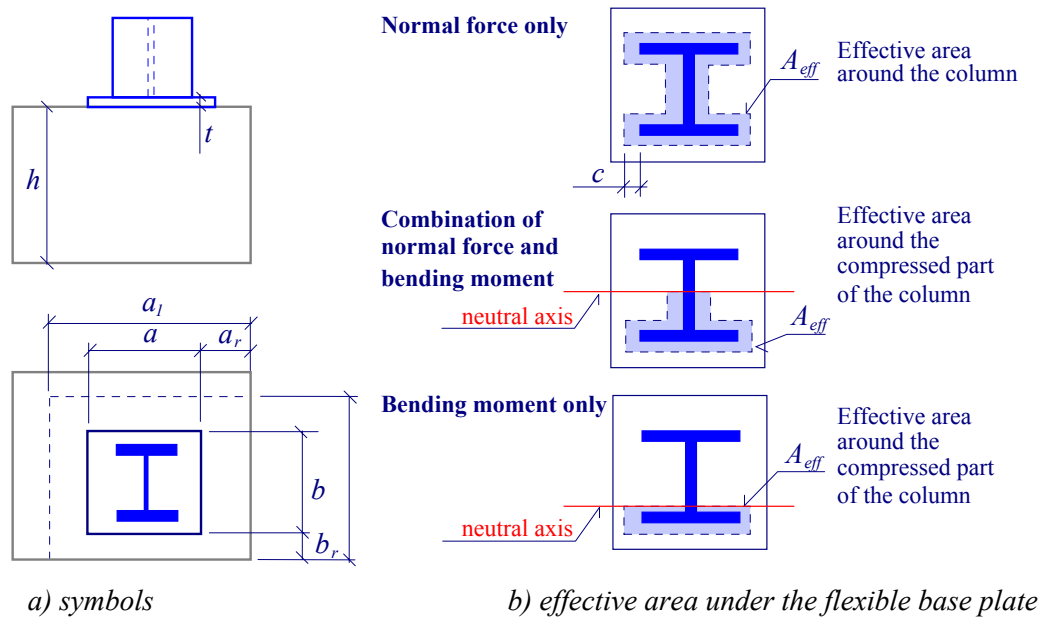

Figure 7.7 Concrete foundation

Q&A 7.5 Effective Length of a Base Plate T-stub

Can the table with effective lengths for end-plate connections be used for base plates?

The effective length of a T-stub in tension is affected by the failure mode of the T-stub. The T-stubs in a base plate are similar to T-stubs in an end plate beam to column joint, but the failure modes may be different. This is because of the long anchor bolts and thick base plate compared to an end plate. This usually results in uplift of the T-stub from the concrete foundation and therefore prying of anchor bolts is not observed, see Figure 7.8. This results in a new collapse mode called 1*. The resistance of the T-stub without contact with the concrete is

$$F_t = \frac{2 L_{eff} m_{pl,Rd}}{m}, \quad (7.10)$$

where $m_{pl,Rd}$ is plastic bending moment resistance of the base plate of unit length. The relationship of failure mode 1* and failure modes of T-stub with contact is shown on Figure 7.9, $B_{t,Rd}$ where design resistance of bolt in tension.

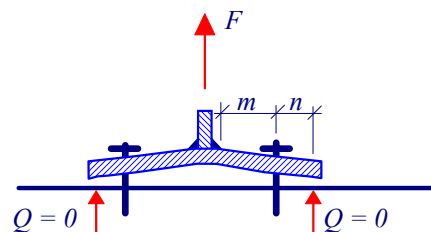

Figure 7.8 T-stub without contact with the concrete block

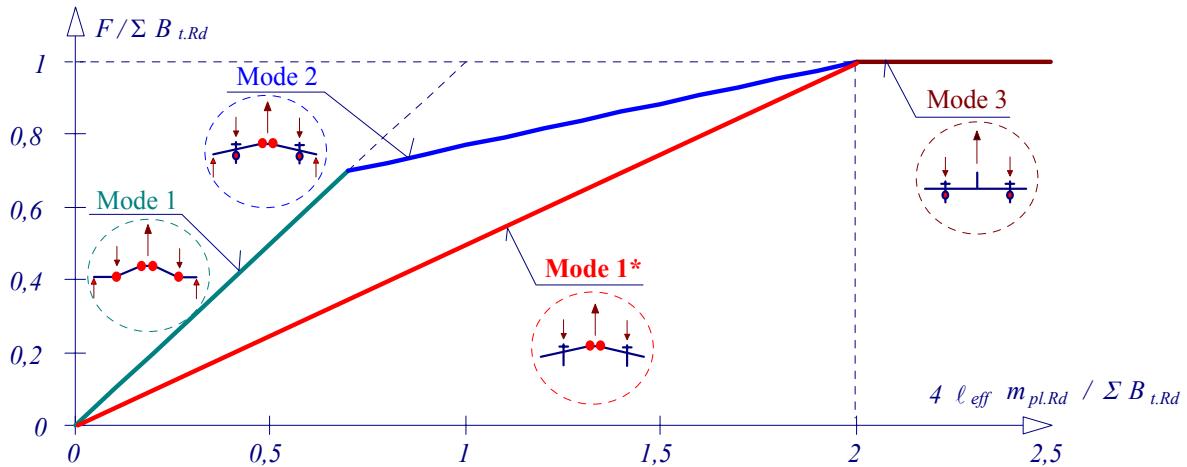

Figure 7.9 Failure mode 1* for the T-stubs of column base

The boundary between the modes with and without contact may be found from an analysis of elastic deformations of the T-stub. It can be expressed in several ways, for example as the limiting bolt length $L_{b,lim}$. No contact and prying of the anchor bolts occurs for bolts longer than $L_{b,lim}$. The limit is

$$L_{b,lim} = \frac{8,82 m^3 A_s}{L_{eff} t^3} < L_b, \quad (7.11)$$

where A_s is the bolt area and L_b is the free length of the anchor bolt, see Figure 7.10, where t_n is the nut height. For bolts embedded in the concrete foundation, the length L_b may be assumed to be the length above the concrete surface L_{bf} and the effective length of the embedded part estimated as $L_{be} = 8 d$, e.g. $L_b = L_{bf} + L_{be}$ [Wald, 1999].

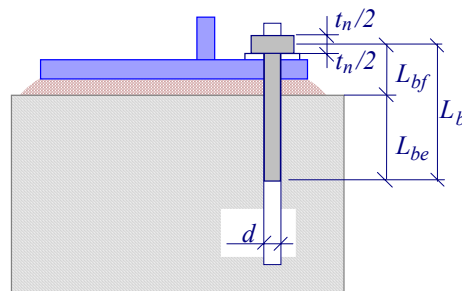
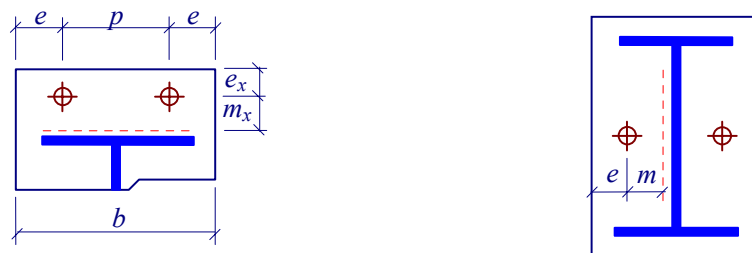

Figure 7.10 Free length of bolts embedded in concrete foundation

The effective lengths of the T-stub L_{eff} of a base plate, see Figure 7.11, are summarized in Table 7.1 and Table 7.2.



a) bolts outside the column flanges

b) bolts inside the column flanges

Figure 7.11 Dimensions of base plate with bolts inside and outside the column flanges

Table 7.1 Effective lengths for a T-stub of base plate with bolts outside the column flange

Prying occurs	No prying
$L_1 = 4 m_x + 1,25 e_x$	$L_1 = 4 m_x + 1,25 e_x$
$L_2 = 2 \pi m_x$	$L_2 = 4 \pi m_x$
$L_3 = 0,5 b$	$L_3 = 0,5 b$
$L_4 = 2 m_x + 0,625 e_x + 0,5 p$	$L_4 = 2 m_x + 0,625 e_x + 0,5 p$
$L_5 = 2 m_x + 0,625 e_x + e$	$L_5 = 2 m_x + 0,625 e_x + e$
$L_6 = \pi m_x + 2 e$	$L_6 = 2 \pi m_x + 4 e$
$L_7 = \pi m_x + p$	$L_7 = 2 \pi m_x + 2 p$
$L_{eff.1} = \min(L_1; L_2; L_3; L_4; L_5; L_6; L_7)$	$L_{eff.1} = \min(L_1; L_2; L_3; L_4; L_5; L_6; L_7)$
$L_{eff.2} = \min(L_1; L_3; L_4; L_5)$	$L_{eff.2} = \min(L_1; L_3; L_4; L_5)$

Table 7.2 Effective lengths for a T-stub of base plate with bolts inside the column flanges

Prying occurs	No prying
$L_1 = 2 \alpha m - (4 m + 1,25 e)$	$L_1 = 2 \alpha m - (4 m + 1,25 e)$
$L_2 = 2 \pi m$	$L_2 = 4 \pi m$
$L_{eff.1} = \min(L_1; L_2)$	$L_{eff.1} = \min(L_1; L_2)$
$L_{eff.2} = L_1$	$L_{eff.2} = L_1$

Q&A 7.6 Base Plates with Bolts outside the Column Flange

The tables for calculating the effective width of a T-stub include cases where all the bolts are placed within the width of the column flange. Can these formulas be used when the bolts are placed the column flanges?

The yield line patterns for plates with bolts placed outside the width of the column flanges were studied by Wald [Wald et al, 2000]. The formulas in the tables for beam to column joints need to be extended to include an additional pattern.

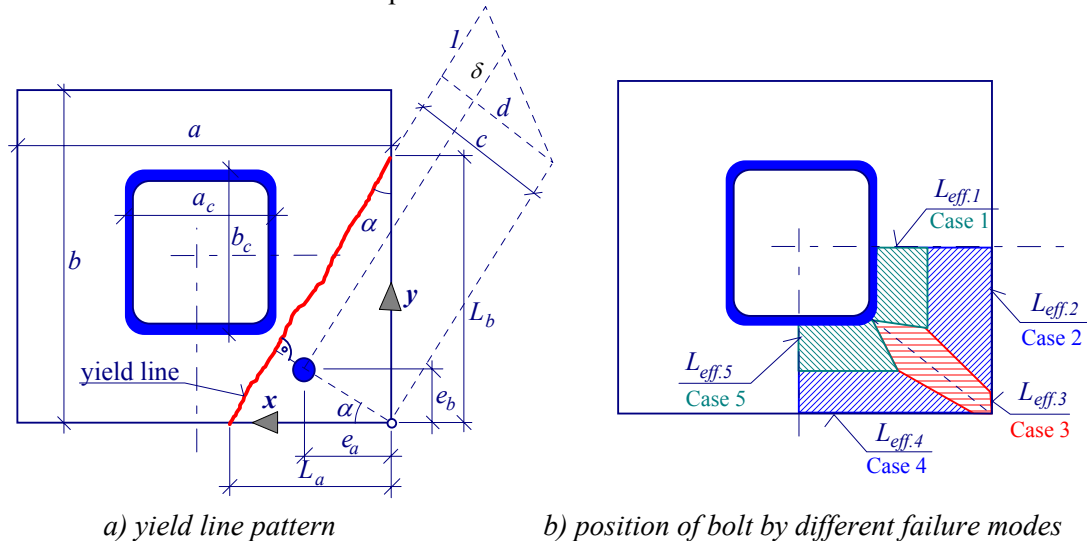

Figure 7.12 Base plate with bolts outside the column flange width

The position of the bolt is described by its coordinates x and y . The yield line is a straight line perpendicular to a line passing through the bolt and the corner of the plate. The angle α represents deviation of the yield line and c is the minimal distance from the corner of the plate to the yield line. Yield line theory together with the principle of virtual energy can be used to determine the parameter c . The internal energy of the yield line is

$$W_i = m_{pl} \left(\frac{l}{y} x + \frac{l}{x} y \right). \quad (7.12)$$

The external energy is

$$W_e = F_{pl} \delta, \quad (7.13)$$

The internal and external energy should be equal, therefore

$$m_{pl} \left(\frac{l}{y} x + \frac{l}{x} y \right) = F_{pl} \delta. \quad (7.14)$$

The virtual displacement δ represents deformation of the plate at the bolt position, see Figure 7.12, and is equal to

$$\delta = \frac{\sqrt{x^2 + y^2}}{c}. \quad (7.15)$$

Substituting the displacement δ into the previous equation

$$F_{pl} \frac{\sqrt{x^2 + y^2}}{c} = m_{pl} \left(\frac{x^2 + y^2}{x y} \right), \quad (7.16)$$

and

$$F_{pl} = m_{pl} c \frac{\sqrt{x^2 + y^2}}{x y}, \quad (7.17)$$

$$\frac{\partial F_{pl}}{\partial c} = m_{pl} \frac{\sqrt{x^2 + y^2}}{x y} = \text{const}. \quad (7.18)$$

Therefore, the effective length L_{eff} is equal to

$$L_{eff} = c \frac{\sqrt{x^2 + y^2}}{x y}. \quad (7.19)$$

Five yield line patterns may be observed at the corner of the column, see Table 7.3, [Wald et al, 2000]. Assuming there is no contact between the edge of base plate and the concrete surface, than prying of the bolts does not exist.

Table 7.3 Calculation of the effective length of a T-stub, Cases 1 to 3

Case 1	Case 2	Case 3
$W_{ext} = F_{pl} \delta$	$W_{ext} = F_{pl} \delta$ $\delta = \frac{a - a_c - 2 e_a}{a - a_c}$	$W_{ext} = F_{pl} \delta$ $\delta = \frac{\sqrt{(b - b_c)^2 + (a - a_c)^2} - 2 \sqrt{e_a^2 + e_b^2}}{\sqrt{(b - b_c)^2 + (a - a_c)^2}}$
$W_{int} = 4 \pi m_{pl} \delta$	$W_{int} = m_{pl} \frac{b}{a - a_c}$	$W_{int} = m_{pl} \left(\frac{e_a}{e_b} + \frac{e_b}{e_a} \right)$
$F_{pl} = 4 \pi m_{pl}$	$F_{pl} = m_{pl} \frac{b}{a - a_c - 2 e_a}$	$F_{pl} = \frac{m_{pl}}{\delta} \left(\frac{e_a}{e_b} + \frac{e_b}{e_a} \right)$
$m = \frac{a - a_c}{2} - e_a$		
$L_{eff.1} = \pi m$	$L_{eff.2} = \frac{b}{4}$	$L_{eff.3} = \frac{\sqrt{(a - a_c)^2 + (b - b_c)^2}}{8} \left(\frac{e_a}{e_b} + \frac{e_b}{e_a} \right)$

The Cases 4 and 5 are similar to Cases 2 and 1, respectively. The results of the FE simulation are shown at Figure 7.13.

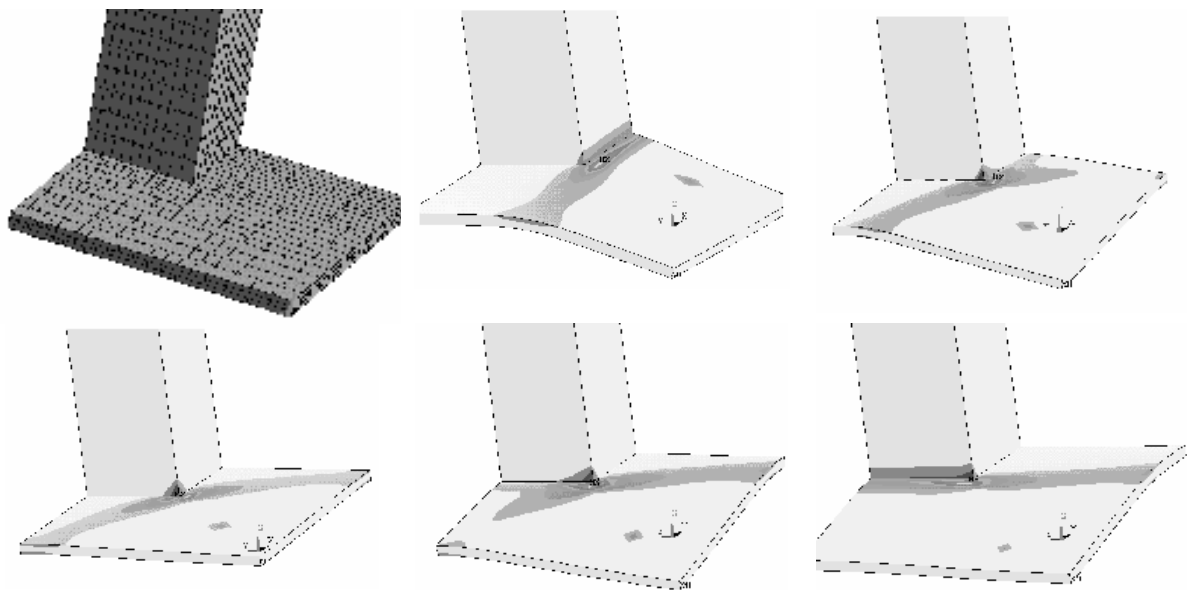

Figure 7.13 Finite element simulation of yield line patterns, the mesh, different yield patterns for variable position of the anchor bolt on the base plate

Q&A 7.7 Slip Factor between Steel and Concrete

What is the slip factor between steel and concrete?

In prEN 1993-1-8: Clause 6.2.1.2 [prEN 1993-1-8: 2003], the coefficient of friction between the base plate and ground layer is given. A value of $C_{f,d} = 0,20$ is used for sand-cement mortar and a value of $C_{f,d} = 0,30$ for special grout.

CEB Guide [CEB, 1997] and [Eligehausen, 1990] suggests that a friction coefficient of $0,4$ may be used when a thin layer of grout less than 3 mm is used. In this case, a partial safety factor for the ultimate limit state $\gamma_{Mf} = 1,5$ should be used.

Q&A 7.8 Transfer of Shear Forces by Anchor Bolts

Can anchor bolts be used to transfer horizontal forces into the concrete foundation?

Horizontal shear force in column bases may be resisted by: friction between the base plate, grout and concrete footing; shear and bending of the anchor bolts; a special shear key, for example a block of I-stub or T-section or steel pad welded onto the bottom of the base plate; direct contact, e.g. achieved by recessing the base plate into the concrete footing, see Fig. 7.14 [Nakashima, 1998]. In most cases, the shear force can be resisted through friction between the base plate and the grout. The friction depends on the minimum compressive load and on the coefficient of friction. Pre-stressing the anchor bolts will increase the resistance of the shear force transfer by friction. In cases, where the horizontal shear force cannot be transmitted through friction between the base plate and the grout due to absence of normal force, the anchor bolts will transmit shear forces or other provisions need to be installed (e.g. shear studs).

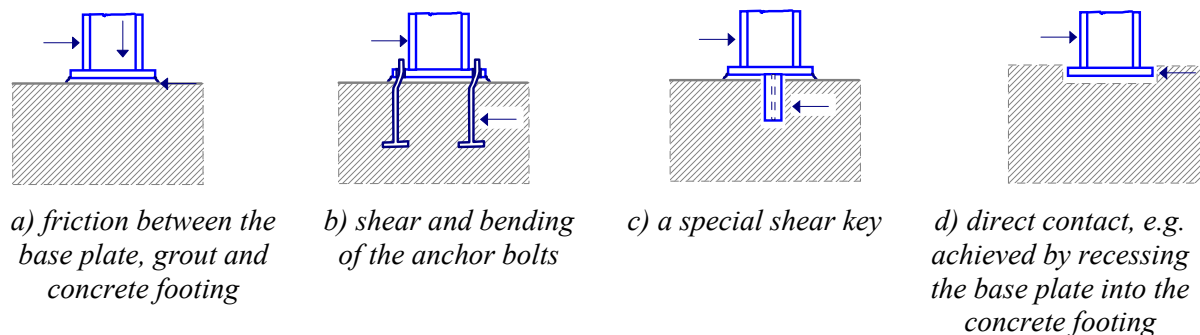

Fig. 7.14 Transfer of horizontal shear force in base plate

The transfer of shear forces by anchor bolts has been good practice in the USA for many years [DeWolf, Ricker 1990]. The bolt holes in the base plate are designed to have clearance as recommended to accommodate tolerance of the bolt position. The design is summarized in CEB document [CEB, 1997]. It is assumed that the anchor bolts will act as a cantilever of span equal to the thickness of the grout increased by $0,5 d$. When rotation of the nut is prevented by the base plate, the span is reduced to $L/2$, see Figure 7.15.

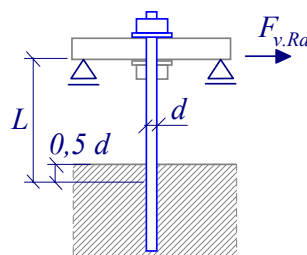

Figure 7.15 Model of anchor bolt in bending, see [CEB, 1997]

In the model of the resistance, described in EN 1993-1-8: 2003, it is assumed the anchor bolts will deflect, which allows the development of a tensile force in the bolt and compression in the grout, see Figure 7.16. This prediction is based on experimental and analytical work by Bouwman [Bouwman et al, 1989]. The design procedure is simplified for practical application and is limited to a shear check.

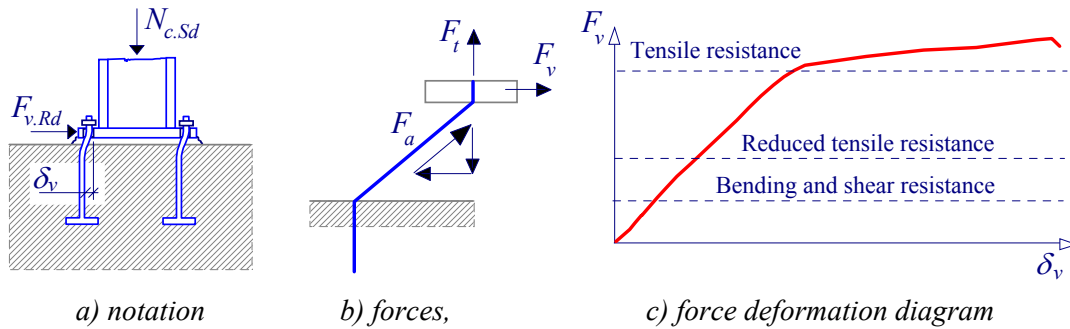

Figure 7.16 Behaviour of an anchor bolt loaded by shear

Q 7.9 Transfer of Shear Forces by Friction and Anchor Bolts

Is it safe to add the friction resistance to the bearing resistances of all the anchor bolts, as clearances in anchor bolt holes are large?

The shear force model used in prEN 1993-1-8: Clause 6.2.1.2 [prEN 1993-1-8: 2003] is based on the assumption that the bolts loaded by a shear force bend, which results in the development of tension in anchor bolts, see Figure 7.16. The resistance of bolts in bending is small, therefore plastic hinges may form in the bolts. This activates hardening effects of the ductile bolt material, see Figure 7.17. Only the anchor bolts in the compressed part of the base plate may be used to transfer shear force. The shear resistance then consist of the friction resistance at the concrete-base plate interface and the reduced tensile resistance of the bolts

$$F_{v,Rd} = F_{t,Rd} + n F_{vb,Rd} \quad (7.20)$$

The resistance of the bolts in bearing in the concrete block and in the base plate should be checked separately.

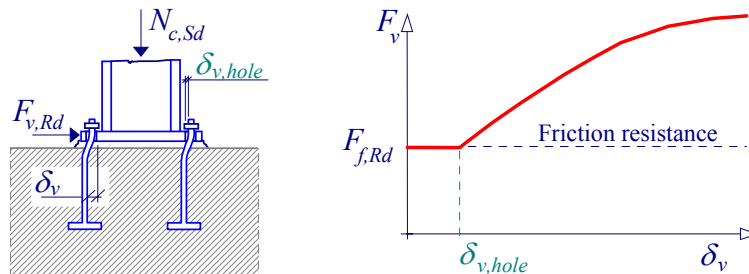

Figure 7.17 The friction resistance and in tension resistance of anchor bolt

Q 7.10 Anchorage rules for Holding Down Bolts

Proper anchorage is the most important criteria for the design of holding down bolts but it is not dealt with in prEN 1993-1-8. What rules should be used?

The rules in prEN 1993-1-8: Table 3.2 for tension resistance of bolts can be used for all steel grades including anchor bolts [Wald, 1999]. The bolt force N_{Sd} should satisfy

$$N_{Sd} \leq F_{t,Rd} = \beta_b \frac{0,9 A_s f_{ub}}{\gamma_{Mb}}, \quad (7.21)$$

where A_s is net area of the bolt, f_{ub} is the ultimate strength of the bolt, γ_{Mb} is partial safety factor for bolted connections and β_b is the reduction factor for cut threads. The factor $\beta_b = 0,85$, if applicable.

Different anchoring types can be used, for example cast-in-situ headed anchors, hooked bars, anchors bonded to drilled holes, undercut anchors, see Figure 7.18 [CEB, 1994]. Anchoring to grillage

beams embedded in the concrete foundation is designed only for column bases loaded by large bending moment, because it is very expensive. Models of design resistance of anchoring compatible with Eurocode were published in CEB Guide [CEB, 1997] based on Eligehausen [Eligehausen 1990]. It is required to verify the following failure modes of single anchor bolt:

- steel failure

$$N_{Sd} \leq N_{a,Rd} \leq N_{Rd,s} = \frac{A_s f_{yb}}{\gamma_{Mb}}, \quad (7.22)$$

- pull-out failure

$$N_{Sd} \leq N_{a,Rd} \leq N_{Rd,p} = \frac{N_{Rk,p}}{\gamma_{Mp}}, \quad (7.23)$$

- concrete cone failure

$$N_{Sd} \leq N_{a,Rd} \leq N_{Rd,c} = \frac{N_{Rk,c}}{\gamma_{Mc}}, \quad (7.24)$$

- and splitting failure of the concrete

$$N_{Sd} \leq N_{Rd,sp} = \frac{N_{Rk,sp}}{\gamma_{Msp}}. \quad (7.25)$$

Similar verification is required for group of anchor bolts.

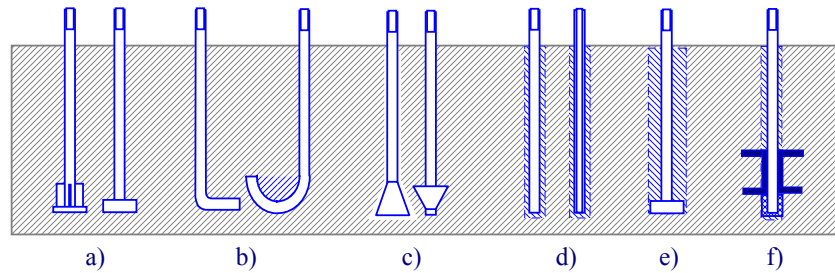

Figure 7.18 Types of anchor bolts, a) cast-in-situ headed anchor bolts, b) hooked bars, c) undercut anchor bolts, d) bonded anchor bolts, e) grouted anchor bolts, f) anchoring to grillage beams

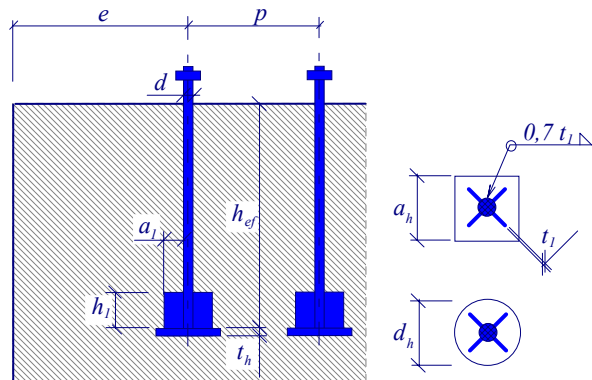

Figure 7.19 Geometry of cast-in-situ headed anchor bolt

Calculation of the design resistance of anchoring by cast-in-situ headed anchor bolts, see Figure 7.19, loaded by tension force is included in the following parts: The pullout design resistance can be obtained as

$$N_{Rd,p} = \frac{p_k A_h}{\gamma_{Mp}}, \quad (7.26)$$

where p_k for non-cracked concrete is taken as

$$p_k = 11,0 f_{ck} \quad (7.27)$$

and A_h is the bearing area of the anchor head for circular and square anchor head

$$A_h = \pi \frac{(d_h^2 - d^2)}{4} \quad (7.28a)$$

$$A_h = a_h^2 - \pi \frac{d^2}{4}. \quad (7.28b)$$

The concrete cone design resistance, see Figure 7.20, is given by

$$N_{Rd,c} = N_{Rd,c}^0 \frac{A_{c,N}}{A_{c,N}^0} \Psi_{s,N} \Psi_{ec,N} \Psi_{re,N} \Psi_{ucr,N}, \quad (7.29)$$

where

$$N_{Rk,c}^0 = \frac{k_1 f_{ck}^{0,5} h_{ef}^{1,5}}{\gamma_{Mc}} \quad (7.30)$$

is the characteristic resistance of a single fastener. The coefficient $k_1 = 11 (N/mm)^{0,5}$ could be taken for non-cracked concrete. The geometric effect of spacing of anchors p and edge distance e is included in the area of the cone, see Figure 7.20, as

$$A_{c,N}^0 = p_{cr,N}^2, \quad (7.31a)$$

$$A_{c,N} = (p_{cr,N} + p_1)(p_{cr,N} + p_2), \quad (7.31b)$$

$$A_{c,N} = (e + 0,5 p_{cr,N}) p_{cr,N}. \quad (7.31c)$$

Width of the concrete cone can be taken approximately

$$p_{cr,N} = 3,0 h_{ef}. \quad (7.32)$$

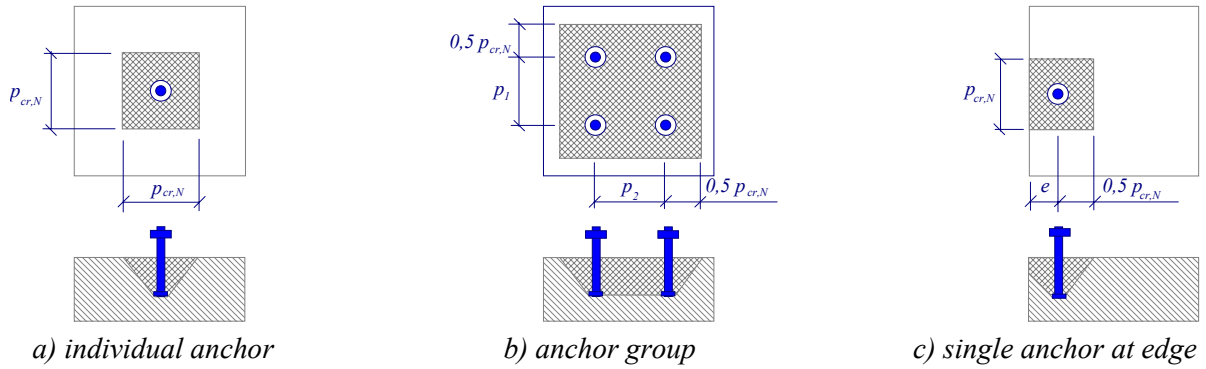

Figure 7.20 Idealised concrete cone

The disturbance of the stress distribution in the concrete can be introduced by using the parameter $\Psi_{s,N}$

$$\Psi_{s,N} = 0,7 + 0,3 \frac{e}{e_{cr,N}} \leq 1. \quad (7.33)$$

This parameter $\Psi_{ec,N}$ is introduced to take into account the effect of a group of anchors. It is used for small embedded depths ($h_{ef} \leq 100 \text{ mm}$). The resistance is increased for anchoring to non-cracked concrete by the parameter $\Psi_{ure,N} = 1,4$. The splitting failure for the in-situ-cast anchors is prevented if the concrete is reinforced and the position of the anchors is limited. Spacing of the anchors should not exceed

$$p_{min} = (5 d_h; 50 \text{ mm}), \quad (7.34)$$

the edge distance should be larger than

$$e_{min} = (3 d_h; 50 \text{ mm}) \quad (7.35)$$

and height of the concrete block, should not be smaller than

$$h_{min} = h_{ef} + t_h + c_{\emptyset}, \quad (7.36)$$

where c_{\emptyset} is the required concrete cover for reinforcement.

For fastenings with edge distance $e > 0,5 h_{ef}$ in all directions, the check of the splitting failure may be omitted. The detailed description of the design resistance of different types of fastenings loaded in tension, shear and a combination of tension and shear forces is included in CEB Guide [CEB, 1994].

8 SEISMIC DESIGN

8.1 Principles

Steel moment frames are widely used for seismic loading. The seismic resistance and behaviour of these frames were highly regarded in USA and Japan prior to the Northridge and Kobe earthquakes. Unfortunately, some steel frames showed damages during these earthquakes, and today engineers are trying to better understand these structures. The unexpected damage effectively invalidated the then-existing design and construction procedures for pre-qualified beam-to-column connections. An extensive research programme was developed to gain a better understanding of why moment connections in special moment resisting frames performed poorly during the earthquake. There is consensus that numerous factors must have contributed to the observed failures including factors that pertain to welding detailing, and design practice that were prevalent prior to the earthquakes.

Detailing practices that appear to have played a role in the earthquake fractures include details that resulted in the development of large stress concentrations, excessive local ductility demands and high tri-axial restraint at the beam-to-column interface.

Poor welding practices include the common use of low toughness weld metal and insufficient quality control. Design practices suspected to have contributed to poor performance include the use of significantly larger members and connections than had previously been tested and the development and use of design provisions that can result in excessively weak panel zones. The standard prEN 1993-1-8 includes rules to determine the strength and stiffness of the steel joints. The influence of the seismic or dynamic loads, which may be considerable in seismic areas, is not covered. Steel structural joints designed for seismic zones must satisfy the following basic conditions:

- over-strength demand;
- ductility demand (rotation capacity);
- robustness demand (reliable detailing together with material behaviour).

8.2 Design criteria

The research leading to the development of design guidelines for new moment resisting steel frame buildings are based on a significant literature search and new analytical and laboratory research on seismic demands, base materials, welds, and fracture mechanics, as well as on full scale and subassembly testing of actual connections. In addition, the study results in new, more rigorous, requirements for quality control of materials and fabrication processes.

In the USA, the guidelines cover designs for frames with different anticipated seismic demands as permitted by the 1997 NEHRP Provisions [BSSC, 1997] and the AISC Seismic Provisions [AISC, 1997], namely Ordinary Moment Resisting Frames (OMRF), Intermediate Moment Resisting Frames (IMRF), and Special Moment Resisting Frames (SMRF). The three frame types are required to be qualified for plastic rotation capacities of $0,01$, $0,02$ and $0,03$ radians respectively and connections can be either fully restrained (FR), or partially restrained (PR). The guidelines provide recommendations for the selection of the appropriate system, for redundancy, for system analysis, for frame design issues, and for the design of suitable connections to meet the anticipated rotation demands of the system selected.

Moment frame performance is a function of many interrelated factors and design relationships, which affect the overall frame performance, as well as, in some cases, the connection performance. Recent studies are intended to determine the effects and importance of, and lead to guidelines for, the following:

- Strong Column/Weak Beam design principle;
- Panel zone strength;
- Connection strength and degradation characteristics;
- P - δ effects;
- Member local buckling.

Connection design guidelines are broken into certain issues generic to most or all connection design and specific design guidelines for the connection types determined to be pre-qualified. The following connection design conditions are considered to be generic, that is, they are conditions which, when

they occur in a connection, are considered to perform in a similar way, or at least to have the same requirements for successful performance, irrespective of the connection type being used.

Welded Joints:

- Through-Thickness Strength;
- Base Material Notch-Toughness;
- Weld Wire Notch-Toughness;
- Weld backing and Run out Tabs;
- Reinforcing Fillet Welds;
- Cope Hole Size, Shape, Workmanship.

Bolted Joints:

- Bolt Sizing, Hole Type, Tightening;
- Net Section Strength.

In Europe, prEN 1993-1-8 gives the steel joint characteristics, as follows:

The moment resistance of a joint $M_{j,Rd}$ should be determined from prEN 1993-1-8 for welded or bolted connections.

The rotational stiffness of a joint S_j should be determined from the flexibilities of its basic components, each represented by its elastic stiffness coefficient k_i . Provided that the axial force N_{Sd} in the connected member does not exceed 10% of the resistance $N_{pl,Rd}$ of its cross-section, the rotational stiffness S_j of a joint, for a moment $M_{j,Sd}$ less than the moment resistance $M_{j,Rd}$ of the joint may be obtained with sufficient accuracy from:

$$S_j = \frac{E z^2}{\mu \sum_i \frac{1}{k_i}} \quad (8.1)$$

Only some provisions concerning the Rotation capacity of steel joints are given in prEN 1993-1-8, and insufficient for a realistic evaluation of the rotational capacity of a joint, especially for a seismic analysis, where rotational capacity is very important. Other important provisions concerning steel joints subject to seismic loads are given in Eurocode 8.

8.3 Beam-to-column typologies

In USA the FEMA/SAC test programmes provided sufficient data to permit reliable design guidelines to be developed for at least ten types of welded connections. Each connection type is classified as suitable for certain ranges of member size, and of certain ranges of plastic rotation angle. The types of connections listed below are pre-qualified for use. Figures are provided to show the general configuration of each connection type.

- Welded Unreinforced Flange (WURF), similar to Figure 8.1a, but with design improvements;
- Welded Cover Plated Flange (WCPF);
- Welded Flange Plates (WFP), see Figure 8.1b;
- Welded Vertical Ribbed Flange (WVRF);
- Welded Column Tree with Bolted Beam (WCT/BB), see Figure 8.1c;
- Welded Single Haunch (WSH);
- Welded Double Haunch (WDH).

In addition to the welded connection types noted above, several field bolted types of connections are included in the guidelines as pre-qualified for certain conditions of use. The types, which may be selected, are listed below.

- Bolted End Plate (BEP), see Figure 8.1d;
- Welded Flange Plates with Bolted Beam (WFPBB), see Figure 8.1e;
- Bolted Single Haunch (BSH), see Figure 8.1f;
- Bolted Double Haunch (BDH), see Figure 8.1f.

Some specific joints utilised in Japan are presented in Figure 8.2. Figure 8.3 shows some usual joints utilised and tested in Europe [Mazzolani, 2000].

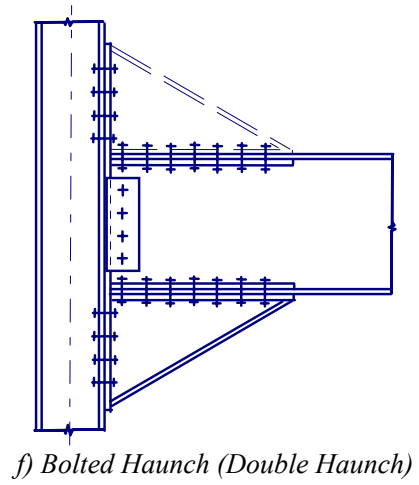
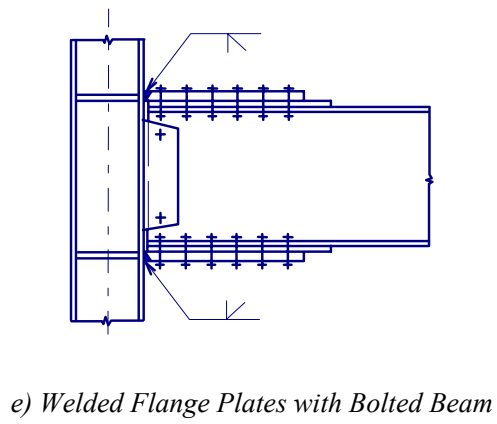
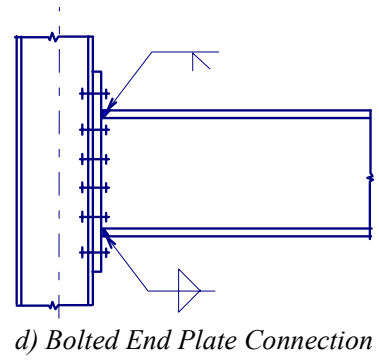
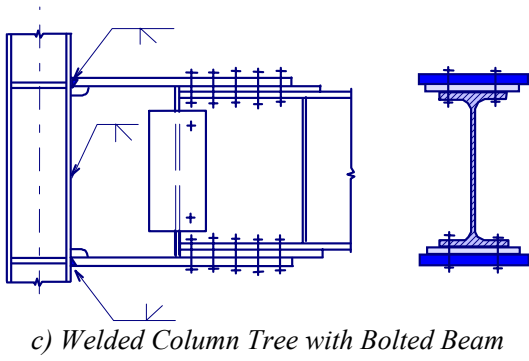
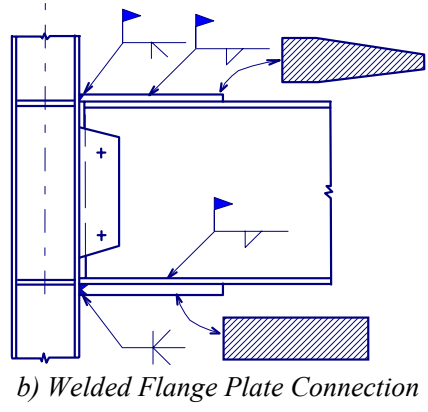
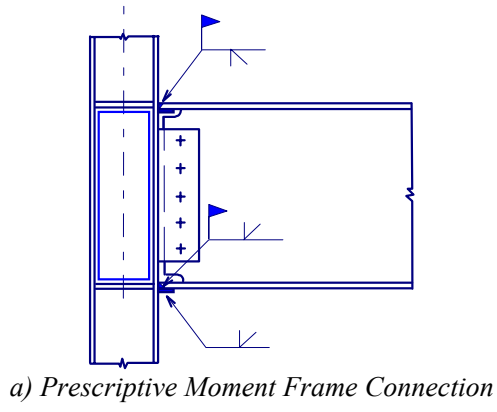

Figure 8.1 Specific joints in USA

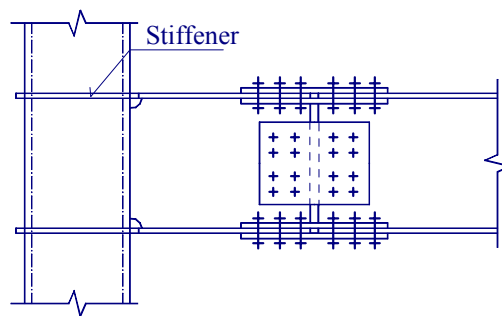
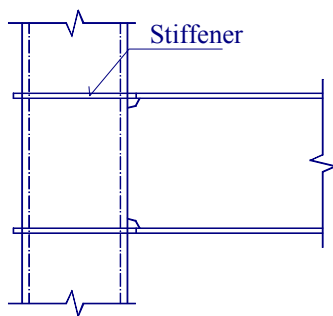

Figure 8.2 Specific joints in Japan

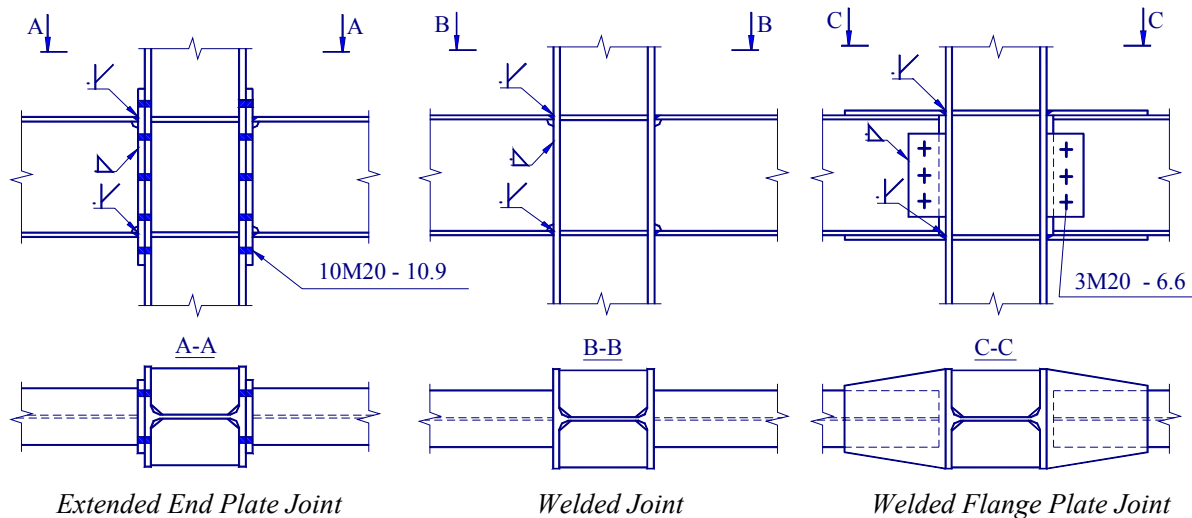

Figure 8.3 Specific joints in Europe

8.4 Design and fabrication recommendations

prEN 1998-1 [prEN 1998-1, 2003] provides the following general rules for steel connections in dissipative structures:

- The adequacy of design should prevent localisation of plastic strains, high residual stresses and fabrication defects. The adequacy of design should be supported by experimental evidence.
- Non dissipative connections of dissipative members made by means of full penetration butt welds are deemed to satisfy the overstrength criterion.
- For fillet weld or bolted non dissipative connections, the following requirements should be met:

$$R_d \geq 1,35 R_{fy} \quad (8.2)$$

- Only categories B and C of bolted joints in shear and category E of bolted joints in tension should be used, with controlled tightening of the bolts. Shear joints with fitted bolts are also allowed.
- For bolted shear connection, the shear resistance of the bolts should be higher than 1,2 times the bearing resistance.
- The strength and ductility of members and their connections under cyclic loading should be supported by experimental evidence, in order to comply with specific requirements defined for each structural type and structural ductility classes. This applies to all types of connections in dissipative zones. The requirements on ductility are expressed for various structural types in Clauses 6.6 and 6.9. When expressed in term of available plastic rotation

$$\phi_p = \delta / (0,5 L) \quad (8.3)$$

The same standard prEN 1998-1 provides the following requirements for MRF (Moment Resistant Frame) beam-to-column connections:

- If the structure is designed to dissipate energy in the beams, the connections between the beams and the columns should be designed for the required degree of overstrength, taking into account the moment resistance $M_{pl,Rd}$ and the shear force $(V_{G,Ed} + V_{M,Ed})$ evaluated in 6.6.2 of standard prEN 1998-1.
- Dissipative semi-rigid and/or partial strength connections are permitted provided that all of the following conditions are satisfied: a) the connections have a rotation capacity consistent with global deformations; b) members framing into the connections are demonstrated to be

stable at the ultimate limit state (ULS); c) the effect of connections deformation on global drift is taken into account.

- The connection design should be such that the plastic rotation capacity ϕ_{cd} in the plastic hinge, is not less than 35 mrad for structures of ductility class H and 25 mrad for structures of ductility class M with $q > 2$. These values should be obtained under cyclic loading without degradation of strength and stiffness greater than 20%; they should be supported by experimental evidence. This requirement is valid independently of the intended location of the dissipative zones.
- When partial strength connections are used, the column capacity design should be derived from the plastic capacity of the connections.

The influence of local geometric details and material properties on the inelastic behaviour of fully restrained steel connections has been investigated in different countries in the last years. Some of the conclusions are presented below [El-Tawil et al, 2000], [Mao et al, 2001]:

Material properties – Yield-to-Ultimate Stress Ratio (YUSR)

Connections with YUSR (f_y/f_u) equal to $0,65$ or $0,80$ behaved in a similar manner for a plastic rotation capacity up to $0,030 \text{ rad}$. Compared with these two specimens, connection with YUSR = $0,95$ had a significantly reduced plastic hinge length at a plastic rotation capacity of $0,030 \text{ rad}$. The plastified length of the beam with YUSR = $0,95$ was about half the corresponding length in YUSR = $0,80$. The smaller plastified length increased the local strains, which in turn promoted earlier local buckling. These elevated strains also increase susceptibility to low cycle fatigue failure.

Local details – Access Hole Size and Geometry

Increasing the size of the web cope would permit easier welding on the beam bottom flange, and possibly promote better weld quality [Chi et al, 2000]. However, the analyses suggest that it is important to use a small access hole to minimise the potential for ductile fracture at the root of the hole. The analysis confirms that the access hole in which the web terminates perpendicular to the flange is inferior to the semicircular detail from the ductile fracture point of view.

Local details – Continuity Plates

FEMA-267 recommendations require the use of continuity plates in all connections. However, the analyses suggest that the provisions may be relaxed with regard to continuity plate thickness for one-sided connections.

Q&A 8.1 Connections Subject to Dynamic Load

Is prEN 1993-1-8 applicable to connections subject to dynamic load, particularly wind load, in addition to static loads?

prEN 1993-1-8 is partially applicable to connections subject to dynamic load. Concerning the moment resistance $M_{j,Rd}$ and the initial rotational stiffness $S_{j,ini}$ of the joint, the relations given by prEN 1993-1-8, can be utilised for dynamic loads.

Concerning the rotation capacity of steel joints, provisions given in prEN 1993-1-8 do not cover the typology of steel joints. However, an experimental research programme, has observed that the rotation capacity of joints subject to dynamic load is approximately $0,5$ times the rotation capacity determined under a static load.

The collapse mechanism could also be modified in dynamic behaviour, compared with the collapse mechanism determined from prEN 1993-1-8 for static loading, according to the weakest component of the joint, see [Grecea, 2001].

Q&A 8.2 Influence of Unsymmetrical Loading

Is prEN 1993-1-8 applicable to connections subject to seismic load, particularly unsymmetrical seismic load, in addition to static loads?

The conclusions of a research program developed in European countries [Mazzolani, 2000] are that the values of the characteristics given by the prEN 1993-1-8 cannot be utilised in these conditions of loading.

A comparison between the values given in prEN 1993-1-8 and the characteristics determined on joints subject to cyclic symmetrical loading was given in the previous answer. A project comparing joints subject to cyclic symmetrical loading and joints subject to cyclic unsymmetrical loading was carried out with some interesting conclusions. Concerning the moment resistance, the values obtained with the second group are smaller by 20-40%, depending of the joint configuration. The rotation capacity of the second group was 150-200% times the rotation capacity of the first group, depending on the joint configuration.

Q&A 8.3 Influence of Strain-Rate Loading

What is the influence of strain-rate loading on the behaviour of steel joints?

An experimental research programme [Mazzolani, 2000] concluded that the strain-rate loading has an important influence on the behaviour of joints.

A strain rate in the range of $0,03-0,06 \text{ s}^{-1}$ (typical for steel members yielding under seismic action) increases the yield strength and, to a lower extent, the ultimate strength of welded connections; for structural steel this phenomenon is well known. Ductility is reduced by up to 27%. However, a decrease of ductility due to high strain rates is not straightforward for cyclic loading, where the results are rather scattered.

Q&A 8.4 Welding Technology

What is the influence of welding technology and detailing on the behaviour of steel joints?

Experimental tests performed under the COPERNICUS RECOS [Mazzolani, 2000] project showed the importance of the quality of welding. Three types of welds were studied (double bevel, fillet and single bevel), and the “ideal” behaviour (rupture in the base metal) was observed for the double bevel welds. This fact is attributed to the lack of defects for this welding procedure, in comparison to the other two procedures [Dubina, Stratan, 2002]. Fillet welded specimens were characterised by an intermediary behaviour, the main cause of failures in welds being the undersized welds. This fact demonstrates one of the disadvantages of this type of welding, which is the difficulty to control and verify the weld size, particularly on a building site. Single bevel weld specimens had, in general, an unsatisfactory behaviour, due to incomplete penetration at the root of the weld, which initiated cracks in the weld region.

The behaviour of the three weld types have to be analysed in conjunction with the technological and economical aspects of welding. Single bevel and double bevel welds require supplementary mechanical operations (edge preparation), while double bevel and fillet welds require overhead position in the case of site welding. The following recommendations are proposed for the particular case of beam-to column joints in moment-resisting frames:

- Double bevel and fillet welds are recommended for shop welding of the subassemblies, with the condition of strict verification of weld size in the case of fillet welds.

- Single bevel welds are adequate for site welding, but re-welding of the root is compulsory in order to eliminate defects at the root of the weld.

Cyclic loading increases the probability of weld fracture for partial joints (undersized fillet welds), and for welds with defects (single bevel welds). It is to be stressed that weld defects such as undersized fillet welds and incomplete penetration single bevel welds were observed both for beam-to-column joints tests, as well as for welded connection tests. This fact shows the need for the strict control of welding quality.

Specific tests performed in USA and Japan showed that US construction uses self-shielded flux core metal arc welding (FCAW), while Japanese construction uses gas shielded metal arc welding (GMAW) with carbon dioxide (CO₂) shielding gas. The comparison suggests that GMAW is more costly, but it may provide greater toughness.

In numerous inelastic cyclic connection tests with notch tough beam flange welds, fracture initiating at the toe of the weld access holes was observed. An effort was made to study the influence of access hole geometry and size on the potential of ductile fracture initiation near the holes. The results indicate the importance of selecting a proper weld access hole configuration. The modified weld access hole geometry shown as configuration b) in Figure 8.4 is recommended for seismic restraint design in comparison with the standard configuration a) [Mao et al, 2001].

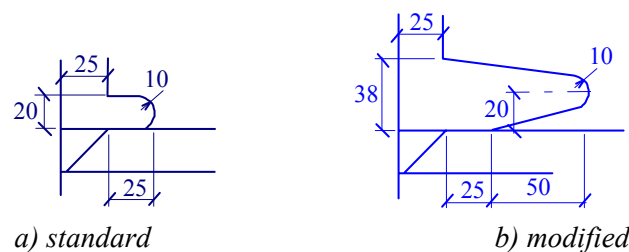

Figure 8.4 Configurations of weld access hole

The web attachment detail was found to have a significant effect on the fracture potential of the beam flanges near the interface of the weld metal and base metal. Based on the analysis results, a detail consisting of a complete penetration groove welded beam web in conjunction with supplemental fillet welds on the shear tab is recommended for seismic design. Weld procedures using a notch tough electrode for the beam web groove weld must be carefully followed to minimise weld defects. In addition, a stronger panel zone is recommended. The bolted shear tab detail is recommended for use only in ordinary moment resisting frames.

Different analyses provide evidence that with higher toughness materials and significant detailing improvements, such as backing bar removal, slight overmatching of weld strengths, and limited panel shear deformations, connections can achieve the target inelastic rotation of $0,030 \text{ rad}$ prior to weld root fractures.

Q&A 8.5 High Strength Bolts in Seismic Joints

Is it possible to use High Strength bolts as ordinary bolts in seismic joints?

High strength bolts (in US HSFG, High Strength Friction Grip bolts) can be used as ordinary bolts in seismic joints. It is recommended that they are tightened at a level of 50% of their preloading force. In this case the surfaces of the plates do not have to be prepared for working as a slip-resistant connection, see Q&A 6.8.

Q&A 8.6 Column Web Panel

What is the influence of the column web panel in a joint subject to dynamic loads?

The behaviour of the column web panel is described prEN 1993-1-8, but only for static loads. In the case of T joints or double T joints with unsymmetrical loads, the web column panel has a strong influence on the behaviour of the joint. For specific dynamic and seismic unsymmetrical loads, it was demonstrated, that the resistance of the joint is reduced by between 20 - 40% and the ductility is increased by 150 - 200%, due to the web panel. Adding supplementary web plates on the column web panel, as shown in Figure 8.5, can increase the resistance of the joint. The solutions have advantages and disadvantages. The first solution, see Figure 8.5a, is the optimum for static loads (the effective with formulas for b_{eff} see in prEN 1993-1-8) and requires supplementary plates to be welded to the toe of the root radius. This introduces additional stresses into the joint. In the second solution, see Figure 8.5b, welding the supplementary plate to the flanges avoid the additional stresses in the flange/web, see [Dubina et al, 2000]. This solution reduces the length of the flange and may cause problem for minor axes beams.

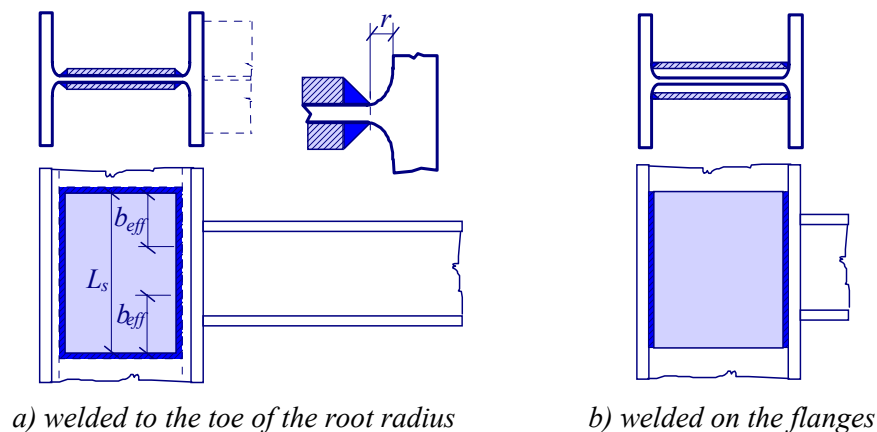

Figure 8.5 Supplementary web plates

Concerning the subject of seismic behaviour of steel frames with deformable panel zones, an interesting conclusion was made by [Schneider, Amidi, 1998] after a numerical study, saying that current provisions governing the minimum strength design of panel zones might result in joints with high shear distortions, which increases the potential for flange fracture of the girder framing into the joint. These results suggest that the 1991 NEHRP provision requiring the panel zone strength to be greater than 90% of the sum of the beam strengths at the joint appears to be a minimum.

9 FIRE DESIGN

When subject to fire steel loses both its strength and stiffness. Steel structures also expand when heated and contract on cooling. Furthermore the effect of restrained to thermal movement can introduce high strains in both the steel member and the associated connections.

Fire tests on steel structures have shown that the temperature within the connections is lower compared to connecting steel members. This is due to the additional material around a connection (column, end-plate, concrete slab etc.) which significantly reduces the temperatures within the connections compared to those at the centre of supported beam.

PrEN 1993-1-2 [prEN 1993-1-2: 2003] gives two approaches for the design of steel connections. In the first approach fire protection is applied to the member and its connections. The level of protection is based on that applied to the connected members taking into account the different level of utilisation that may exist in the connection compared to the connected members. A more detailed approach is used in the second method which uses an application of the component approach in prEN 1993-1-8 together with a method for calculation the behaviour of welds and bolts at elevated temperature. By using this approach the connection moment, shear and axial capacity can be evaluated at elevated temperature [Simões da Silva et al, 2001], [Spyrou et al, 2002].

Traditionally steel beams have been designed as simply supported. However it has been shown in recent large scale fire tests on the steel building at Cardington [Moore, 1997], in real fires [SCI recommendation, 1991], and in experimental results on isolated connections [El-Rimawi et al, 1997], that joints that were assumed to be pinned at ambient temperature can provide considerable levels of both strength and stiffness at elevated temperature. This can have a beneficial effect on the survival time of the structure.

Q&A 9.1 Bolts Resistance at High Temperature

How do you calculate the resistance of bolts at high temperature?

Experimental studies [Sakumoto et al, 1992], [Kirby, 1995] have shown that the strength and stiffness of a bolt reduces with increasing temperature. In particular they show a marked loss of strength between 300 and 700°C. The results of this work has been included in prEN 1993-1-2, where $k_{b,\theta}$ is used to describe the strength reduction with elevated temperature. $k_{b,\theta}$ is given in Figure 9.1. Table 9.1.

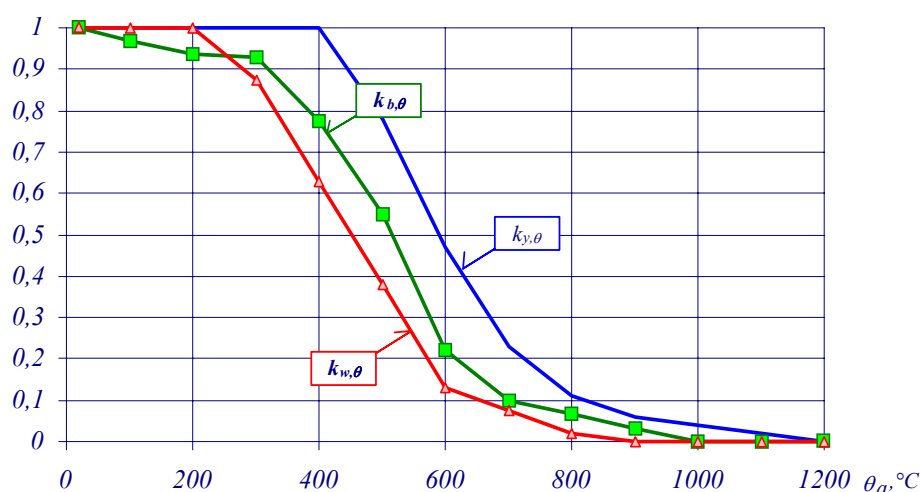

Figure 9.1 Reduction factor $k_{b,\theta}$ for bolt resistance, $k_{w,\theta}$ for weld resistance and $k_{y,\theta}$ for yield strength, prEN 1993-1-2

Table 9.1 Strength reduction factors for bolts,

Temperature θ_a	Reduction factor for bolts in tension and in shear $k_{b,\theta}$	Temperature θ_a	Reduction factor for bolts in tension and in shear $k_{b,\theta}$
20	1,000	500	0,550
100	0,968	600	0,220
150	0,952	700	0,100
200	0,935	800	0,067
300	0,903	900	0,033
400	0,775	1000	0,000

The shear resistance of bolts in fire may be evaluated using the following expressions

$$F_{v,t,Rd} = F_{v,Rd} k_{b,\theta} \frac{\gamma_m}{\gamma_{m,fi}}, \quad (9.1)$$

where γ_M is the partial safety factor for the resistance and $\gamma_{M,fi}$ is the partial safety factor for fire. The bearing resistance of bolts in fire may be predicted using

$$F_{b,t,Rd} = F_{b,Rd} k_{b,\theta} \frac{\gamma_m}{\gamma_{m,fi}} \quad (9.2)$$

and the tension resistance of a single bolt in fire is given by

$$F_{ten,t,Rd} = F_{t,Rd} k_{b,\theta} \frac{\gamma_m}{\gamma_{m,fi}}. \quad (9.3)$$

Q&A 9.2 Weld Resistance at High Temperature

How do you calculate the resistance of a welded connection under fire conditions?

The question consists of two parts: calculating the temperature distribution in the joints (see the answer into next question Q&A 9.3, [Franssen, 2002]) and calculating the weld resistance at high temperature. The design strength of a full penetration butt weld, for temperatures up to 700°C, should be taken as equal to the strength of the weaker part of the joint using the appropriate reduction factors for structural steel. For temperatures higher than 700°C the reduction factors given in prEN 1993-1-2 for fillet welds can be applied to butt welds. Design strength per unit length of a fillet weld in a fire may be calculated as

$$F_{w,t,Rd} = F_{w,Rd} k_{w,\theta} \frac{\gamma_m}{\gamma_{m,fi}}. \quad (9.4)$$

Q&A 9.3 Temperature Distribution with Time within a Joint

Can the simplified formulas of temperature distribution, indicated in prEN 1993-1-2, be used for all joints?

The thermal conductivity of steel is high. Nevertheless, because of the concentration of material within the joint area, a differential temperature distribution should be considered within the joint. Various temperature distributions have been proposed or used in experimental tests by several authors. According to prEN 1993-1-2, the temperature of a joint may be assessed using the local massivity value (A/V) of the joint components. As a simplification, a uniform distributed temperature may be assumed within the joint; this temperature may be calculated using the maximum value of the ratios A/V of the adjacent steel members. For beam-to-column and beam-to-beam joints, where the beams are supporting any type of concrete floor, the temperature may be obtained from the temperature of the bottom flange at mid span.

Table 9.2 Temperature distribution with time within joint

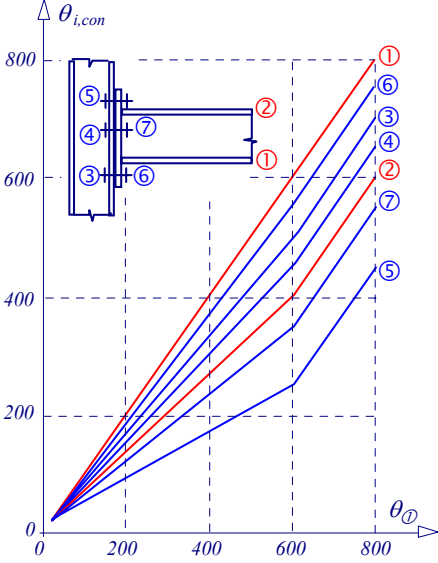
Reference	Temperature distribution																
[Kruppa, 1976]	<p><u>Six joints types</u></p> <p>The principal aim was to establish the performance of high strength bolts. The beams were not attached to the concrete slab. The results indicated that the bolt failure does not occur before large deformation of the others members.</p>																
[Leston-Jones et al, 1997]	<p><u>Double-sided joint with flush end-plate</u></p> <p>Beam: 254x102x22; column: 152x152x23; 3 bolts M16 - 8.8. Furnace to follow a linear steel temperature path, reaching 900°C in 90 min. average temperature profile for all tests:</p> <table border="0" data-bbox="462 537 1236 683"> <tr> <td>Lower beam flange</td> <td>$1,000 \theta_{i,fb}$;</td> <td>Upper beam flange</td> <td>$0,677 \theta_{i,fb}$;</td> </tr> <tr> <td>Beam centre web</td> <td>$0,985 \theta_{i,fb}$;</td> <td>Top bolt</td> <td>$0,928 \theta_{i,fb}$;</td> </tr> <tr> <td>Middle bolt</td> <td>$0,987 \theta_{i,fb}$;</td> <td>Bottom bolt</td> <td>$0,966 \theta_{i,fb}$;</td> </tr> <tr> <td>Column flange</td> <td>$1,036 \theta_{i,fb}$;</td> <td>End plate</td> <td>$0,982 \theta_{i,fb}$;</td> </tr> </table> <p>$\theta_{i,fb}$ temperature of the lower beam flange.</p>	Lower beam flange	$1,000 \theta_{i,fb}$;	Upper beam flange	$0,677 \theta_{i,fb}$;	Beam centre web	$0,985 \theta_{i,fb}$;	Top bolt	$0,928 \theta_{i,fb}$;	Middle bolt	$0,987 \theta_{i,fb}$;	Bottom bolt	$0,966 \theta_{i,fb}$;	Column flange	$1,036 \theta_{i,fb}$;	End plate	$0,982 \theta_{i,fb}$;
Lower beam flange	$1,000 \theta_{i,fb}$;	Upper beam flange	$0,677 \theta_{i,fb}$;														
Beam centre web	$0,985 \theta_{i,fb}$;	Top bolt	$0,928 \theta_{i,fb}$;														
Middle bolt	$0,987 \theta_{i,fb}$;	Bottom bolt	$0,966 \theta_{i,fb}$;														
Column flange	$1,036 \theta_{i,fb}$;	End plate	$0,982 \theta_{i,fb}$;														
[Al-Jabri et al, 1998] and [Al-Jabri et al, 1997]	<p><u>Steel and composite beam-to-column connections</u></p> <p>Furnace to follow a linear steel temperature path, reaching 900°C in 90 min. The hottest of the connection elements was the column web. Its temperature ranged between 8%-26% higher than beam flange temperature. The presence of the concrete slab above the connections caused a 20%-30% reduction in the beam top flange temperatures.</p>																
[Lawson, 1990]	<p><u>Eight beam-to-column connections</u></p> <p>Typical of those used in modern framed buildings (steel and composite connections). Average temperature profile for all tests:</p> <p>$\theta_{lower\ beam\ flange} = 650\ ^\circ C$ and $750\ ^\circ C$</p> <p>$\theta_{upper\ bolts} = 150\ ^\circ C$ to $200\ ^\circ C$ lower than $\theta_{lower\ beam\ flange}$</p> <p>$\theta_{lower\ bolts} = 100\ ^\circ C$ to $150\ ^\circ C$ lower than $\theta_{upper\ bolts}$.</p>																
[Liu, 1996]	<p><u>Double-sided composite joint with extended end-plate connection</u></p> <p>Numerical modelling, temperature profile:</p> <p>For $\approx 45\ min$: $\theta_{lower\ bolts} \approx 650\ ^\circ C$; $\theta_{end\ plate} \approx 550\ ^\circ C$; $\theta_{upper\ bolts} \approx 520\ ^\circ C$</p> <p>$\theta_{column\ web} \approx 450\ ^\circ C$; $\theta_{unexposed\ bolt} \approx 350\ ^\circ C$.</p>																
[SCI recommend, 1990]	<p><u>Joint with extended end-plate</u></p> <p>Considering embedded top bolts, see Figure below.</p> 																
[El-Rimawi et al, 1997]	<p>Assumptions: $\theta_{upper\ beam\ flange} = 0,7 \theta_{lower\ beam\ flange}$; $\theta_{upper\ beam\ flange} = 0,7 \theta_{beam\ web}$</p>																

Applying the expressions referred to in prEN 1993-1-2, see Figure 9.2, the temperature of the joint components may be determined as follows:

The depth of the beam is less than 400 mm

$$\theta_h = 0,88 \theta_0 [1 - 0,3 (a/h)], \quad (9.5)$$

where θ_0 is temperature of the lower beam flange at mid span. The depth of the beam is greater than 400 mm

$$\theta_h = 0,88 \theta_0 \quad a \text{ is less than } h/2 \quad (9.6)$$

$$\theta_h = 0,88 \theta_0 [1 + 0,2 (1 - 2a/h)] \quad a \text{ is grater than } h/2 \quad (9.7)$$

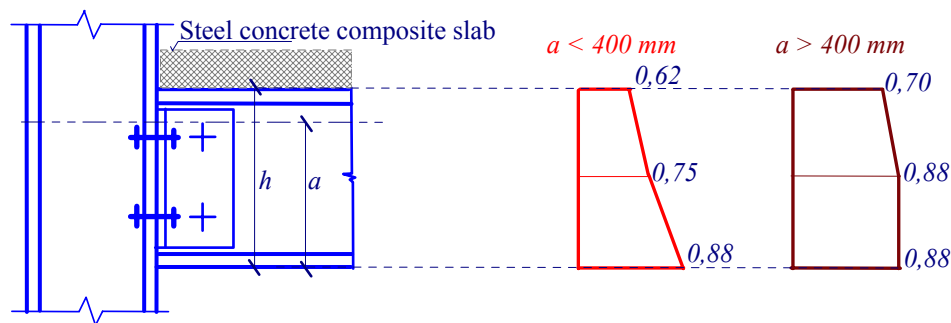

Figure 9.2 Thermal gradient within the depth of connection

With the aim to quantify the temperature distribution within a joint, some tests have been done in several joint typologies. Table 9.2 summarizes the results, showing that for deeper beams a web temperature similar to bottom flange temperature is observed while for small beams a smaller web temperature is observed. Additionally, the presence of the concrete slab above the joint cause a reduction in the beam top flange temperatures. A detailed description can be found in the literature [Kruppa, 1976], [Leston-Jones et al, 1997], [Al-Jabri et al, 1998], [Al-Jabri et al, 1997], [Lawson, 1990], [Liu, 1996], [SCI recommendation, 1990], [El-Rimawi et al, 1997]. The values proposed in prEN 1993-1-2, are in agreement with these experimental results. However, these values are based on the standard fire curve ISO834; if the fire follows other curves, such as hydrocarbon, external fire or a natural fire scenario, it is necessary to analyse the particular case, using a numerical or experimental study.

Q&A 9.4 Component Method under High Temperatures

At ambient temperature, besides presenting rules for the calculation of the resistance of bolts loaded in shear, in bearing and in tension and the design resistance per unit length of a fillet weld, prEN 1993-1-8 presents design rules to determinate the behaviour of the complete joint. Can the method be used at high temperature?

The component method, see [Zoetemeijer, 1974] and [prEN 1993-1-8: 2003], that consists of the assembly of extensional springs and rigid links, may be adapted and applied to the evaluation of the behaviour of steel joints under elevated temperatures. Depending on the objective of the analysis, a simple evaluation of resistance or initial stiffness may be pursued or, alternatively, a full non-linear analysis of the joint may be performed [Simões da Silva et al, 2001], taking into account the non-linear load deformation characteristics of all the joint components, thus being able to predict the moment-rotation response, see Figure 9.3.

To evaluate the non-linear response of steel joints in fire, knowledge of the mechanical properties of steel with increasing temperature is required. In the context of the component method,

this is implemented at the component level. The elastic stiffness, K_e , is directly proportional to the Young's modulus of steel and the resistance of each component depends on the yield stress of steel. Equations (9.8) to (9.10) illustrate the change in component force-deformation response with increasing temperature for a given temperature variation θ of component i .

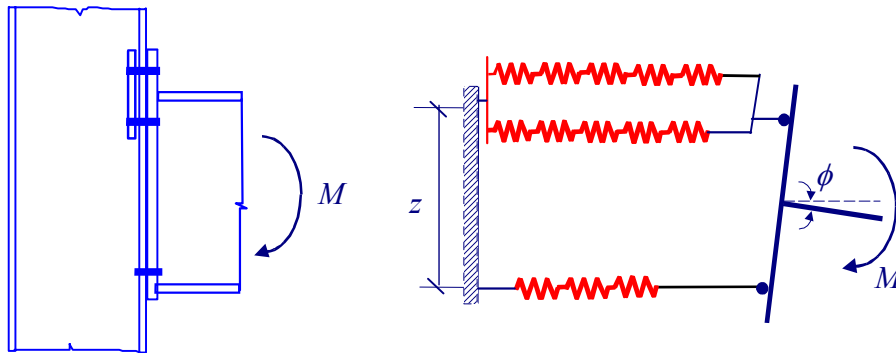

Figure 9.3 Component method applied to a typical beam-to-column joint, a) joint, b) component model

$$F_{i,y,\theta} = k_{y,\theta} F_{i,y,20^\circ\text{C}}, \quad (9.8)$$

$$K_{i,e,\theta} = k_{E,\theta} K_{i,e,20^\circ\text{C}}, \quad (9.9)$$

$$K_{i,pl,\theta} = k_{E,\theta} K_{i,pl,20^\circ\text{C}}. \quad (9.10)$$

Introducing Equations (9.8) to (9.10) for the corresponding (constant) values of K_e , K_{pl} and F_y in any evaluation of moment-rotation response of steel joints at room temperature yields the required fire response. Implementation of this procedure allows the fire resistance to be established in any of two domains:

- Resistance - find reduced resistance at design temperature.
- Temperature - find critical temperature for loading and compare with design temperature.

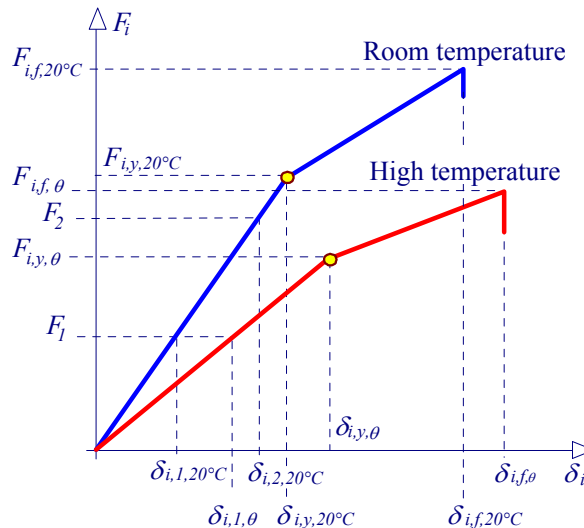

Figure 9.4 Isothermal force-deformation response of component

Resistance

With reference to Figure 9.4, for a given level of applied force F , the component deformation $\delta_{i,\theta}$ is given

$$\text{for } F' < F_{i,y,\theta} \text{ as } \delta_{i,\theta}(F_1) = \delta_{i,1,\theta} = \frac{F_1}{K_{i,e,\theta}} = \frac{F_1}{k_{E,\theta} K_{i,e,20^\circ\text{C}}} = \frac{1}{k_{E,\theta}} \delta_{i,20^\circ\text{C}}(F_1), \quad (9.11)$$

$$\text{for } F = F_{i,y,\theta} \text{ as } \delta_{i,y,\theta} = \frac{F_{i,y,\theta}}{K_{i,e,\theta}} = \frac{k_{y,\theta}}{k_{E,\theta}} \delta_{i,y,20^\circ\text{C}}, \quad (9.12)$$

$$\text{for } F_2 \geq F_{i,y,\theta} \text{ as } \delta_{i,\theta}(F_2) = \delta_{i,2,\theta} = \delta_{i,y,\theta} + \frac{1}{k_{E,\theta}} \frac{\delta_{i,f,20^\circ\text{C}} - \delta_{i,y,20^\circ\text{C}}}{F_{i,f,20^\circ\text{C}} - F_{i,y,20^\circ\text{C}}} (F_2 - F_{i,y,\theta}). \quad (9.13)$$

From equilibrium considerations, the bending moment for a given level of joint deformation is given by

$$M_\theta = F_{r,\theta} z = k_{y,\theta} M_{20^\circ\text{C}} \quad (r=1,2) \quad (9.14)$$

Similar expressions can be derived for stiffness and rotation of the joint, and the initial stiffness of a joint loaded in bending, at temperature θ is given by

$$S_{i,\theta} = \frac{E_\theta z^2}{\sum_i \frac{1}{k_{i,\theta}}} = k_{E,\theta} \times S_{i,20^\circ\text{C}} \quad (9.15)$$

The rotation at yield of the component i follows from

$$\phi'_{i,y,\theta} = \frac{M_{i,y,\theta}}{S_{i,y,\theta}} = \frac{k_{y,\theta}}{k_{E,\theta}} \frac{M_{i,y,20^\circ\text{C}}}{S_{i,2,20^\circ\text{C}}} = \frac{k_{y,\theta}}{k_{E,\theta}} \phi_{i,y,20^\circ\text{C}} \quad (9.16)$$

Equations (9.11) to (9.16) give the generic moment-rotation curve at a constant temperature θ where the yielding sequence of the various components is identified.

Temperature

For a joint under uniform temperature distribution, the critical temperature is defined as the maximum temperature of the joint corresponding to failure of the joint,

$$M_{j,Sd} = M_{j,max,\theta} \quad (9.17)$$

According to prEN 1993-1-2 the evaluation of the critical temperature requires the calculation of the degree of utilization of the joint at time $t = 0$, μ_0 , defined as the relation between the design effect of the actions for the fire design situation and the design resistance of the steel member, for the fire design situation, at time t . For the present case of steel joints, the degree of utilization is explicitly given by:

$$\mu_0 = \frac{M_{j,Sd}}{M_{j,max,20^\circ\text{C}}} \quad (9.18)$$

Using Equation (9.18) allows the direct calculation of the critical temperature of the joint from Equation (9.28) [prEN 1993-1-2: 2003]

$$\theta_{cr} = 39,19 \ln \left[\frac{1}{0,967 \mu_0^{3,833}} - 1 \right] + 482 \quad (9.19)$$

10 HOLLOW SECTION CONNECTIONS

10.1 Introduction

Connecting technology plays an important role in the performance of hollow section structures. A distinction has to be made between CHS and RHS connected members, because the behaviour of joints, e.g. local behaviour of members is different. A particular case is represented by beam-to-column joints in building frames with Concrete Filled Hollow Section (CFHS) columns. Both welded and/or bolted connections can be used in such a case. For beam-to-column joints of hollow section frames (e.g. RHS columns and beams or hollow section columns and I or H section beams), blind bolting technology is available. This section summarises the main aspects concerning the behaviour and design of hollow section connections loaded predominantly statically. This means they can also be used for seismic resistant buildings, since seismic motions are not considered as generating fatigue phenomena. European standard [prEN 1993-1-8: 2003], Chapter 7 gives detailed application rules to determine the static resistances of uni-planar and multi-planar joints in lattice structures composed of circular, square or rectangular hollow sections, and of uni-planar joints in lattice structures composed of combinations of hollow sections with open sections.

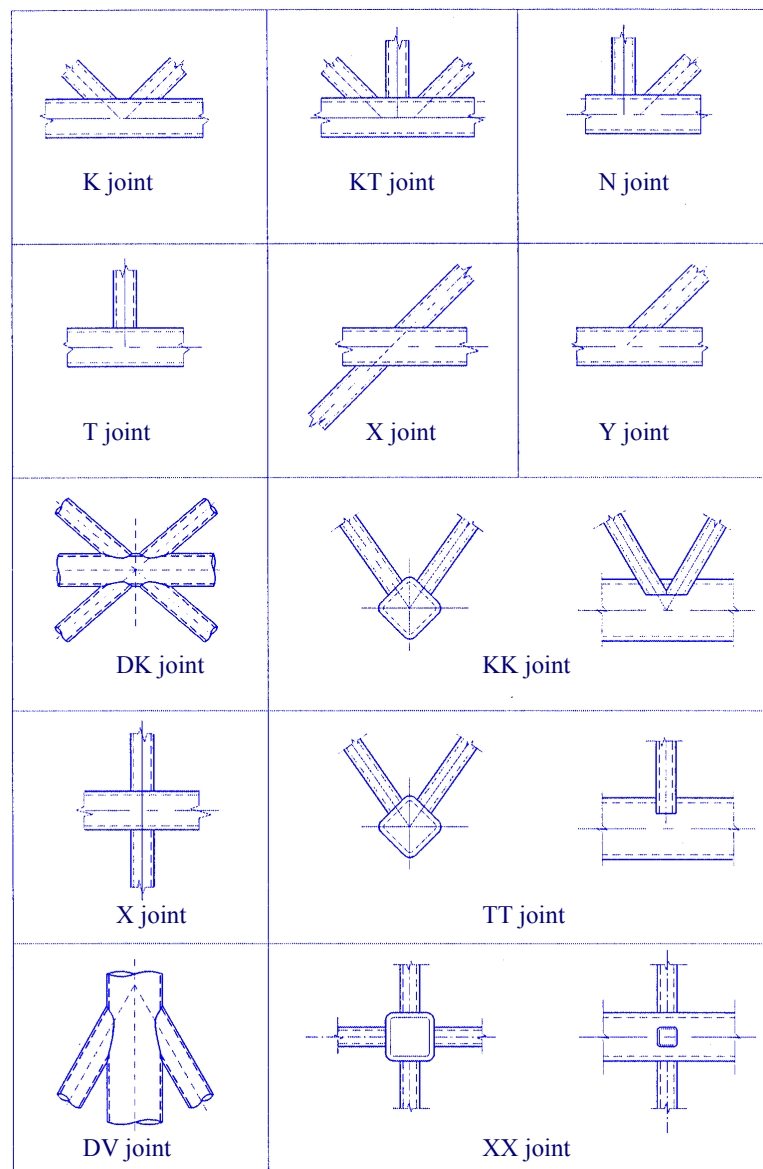

Figure 10.1 Types of joints in hollow section lattice girders

The static resistances of the joints are expressed in terms of maximum design axial and/or moment resistances for the brace members. The application rules are valid both for hot finished hollow sections to EN 10210 and for cold formed hollow sections to EN 10219, if the dimensions of the structural hollow sections fulfil the necessary requirements. The nominal wall thickness of hollow sections should be limited to a minimum of $2,5\text{ mm}$ and should not be greater than 25 mm unless special measures have been taken to ensure that the through thickness properties of the material is adequate. The types of joints covered by standard prEN 1993-1-8 are indicated in Figure 10.1. The application rules given in paragraph 7.1.2 of prEN 1993-1-8 may be used only where all the given conditions are satisfied.

10.2 Welded connections

Even if bolted connections to hollow sections are utilised to assemble prefabricated elements or space structures, the most used method to assemble CHS members is welding, especially for trusses. According to prEN 1993-1-8, the design joint resistances of connections between hollow sections and of connections of hollow sections to open sections, should be based on the following failure modes as applicable:

- Chord face failure (plastic failure of the chord face) or chord plastification (plastic failure of the chord cross-section);
- Chord side wall failure (or chord web failure) by yielding, crushing or instability (crippling or buckling of the chord side wall or chord web) under the compression brace member;
- Chord shear failure;
- Punching shear failure of a hollow section chord wall (crack initiation leading to rupture of the brace members from the chord member);
- Brace failure with reduced effective width (cracking in the welds or in the brace members);
- Local buckling failure of a brace member or of a hollow section chord member at the joint location.

10.3 Bolted connections

Connecting two hollow section members or a hollow section and an open profile or a plate directly to each other by bolting can be difficult unless the joint is located close to the open end of a hollow section member. Otherwise it is necessary to take measures, such as cutting a hand access hole in the structural hollow section member to enable the bolt to be tightened from the inside or using “through” or “blind” bolts. The reason for this special situation is evident, as the hollow section allows free access only to the outside; any access to the inside is restricted.

Bolted connections remain nonetheless desirable in many cases in spite of the unique condition of non-accessibility to the inside of a hollow section. However, in these cases, the hollow sections can be joined indirectly using flange or capping plates, which makes it possible to effect such bolted connections in a simple and economical manner. The main methods of assembly by bolting are described below.

Bolted connections are mostly detachable. They are selected for the on site assembly in order to avoid site welding, which may cause welding errors due to environmental difficulties. Site welding is also more costly than site bolting. This paragraph is presented in accordance with “Design guide for structural hollow sections in mechanical applications” of J. Wardenier et al, see [CIDECT, 1995] and “Guide on the use of bolts: single sided blind bolting systems of N. F. Yeomans [Yeomans, 2002]. The main types of bolted connections for hollow section structures are: Bolted knee joints, Flange connections, Splice joints, Joints with fork ends, Screwed tensioner, Through bolting, Bolted connections with flattened ends, Hinged support, Column bases, Fish plate connections, Bolted subassemblies, and Fixing bolts through hand access holes [CIDECT, 1995; Elremaily, Azizinamini, 2001b; Elremaily, Azizinamini, 2001a]. These connections are realised using intermediate connecting steel devices, which are welded on the hollow section members, the bolted connections themselves being designed as normal connections according to prEN 1993-1-8, Chapter 3 [prEN 1993-1-8: 2003]. For this reason, design of hollow section connections does not imply specific requirements.

10.4 Design considerations

A structure made of hollow sections and loaded by predominantly static loading should be designed in such a way that it has a ductile behaviour. This means that the critical members or joints should provide sufficient rotation capacity. In this case, secondary bending moments due to imposed deformations or due to the joint stiffness may be neglected in design. Where the critical member or connection do not provide sufficient rotation capacity, as in case of thin walled sections, a second order elastic analysis should be used.

Design of hollow section connections should be done in accordance with prEN 1993-1-8 [prEN 1993-1-8: 2003], Chapter 7: Hollow section joints and CIDECT Design guide for structural hollow sections in mechanical applications, Chapter 5: Design considerations for connections [CIDECT, 1995], [Kato, 1988]. Connection detailing for both welded and bolted connections is given in CIDECT Design guide for structural hollow sections in mechanical applications, Chapter 6: Connection detailing [CIDECT, 1995].

Q&A 10.1 Circular Hollow Section Joints

What analytical models are used for calculating the resistance of CHS joints?

The following three models are currently used:

- Tube model for chord face failure
- Model for punching shear failure
- Model for chord shear failure

Tube model for chord face failure

The joint is modelled by a tube of effective length B_e , having a geometry and mechanical characteristics identical with the CHS (Circular Hollow Section Joints) chord as presented in Figure 10.2.

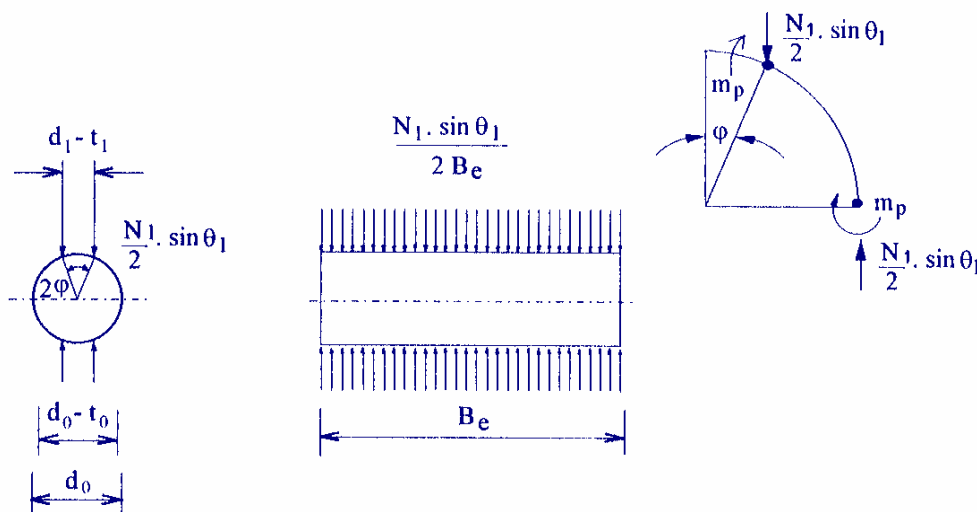

Figure 10.2 Tube model for a X joint of CHS

Neglecting axial and shear forces, and taking into account the effective length B_e , which is determined by tests, the effort corresponding to the plastification of the tube should be:

$$N_{1,y} = \frac{C_0}{1 - C_1 \beta} \cdot f_{y0} \cdot \frac{t_0^2}{\sin \theta_1}, \quad (10.1)$$

where C_0, C_1 are constants, θ_1 is the angle between the diagonal and the chord and $\beta = d_1/d_0$ is the ratio of diameters of the tubes [CIDECT, 1991]. This model gives good results for T, Y and X joints. For more complex joints such as K and N, other parameters like distance between diagonals and axial forces should be taken into account.

Model for punching shear failure

This model is presented in Figure 10.3 for a Y joint subject to tension. The effort in the diagonal is obtained by the formula:

$$N_2 = \frac{f_{yo}}{\sqrt{3}} \pi d_2 t_o \frac{1 + \theta_2}{2 \sin^2 \theta_2} \tag{10.2}$$

This criterion is generally true only for reduced values of β , where $\beta = d_2/d_0$, because if β increases, the load will be transferred to the chord by circular stresses.

Design rules based on the model for punching shear failure are largely used in offshore design.

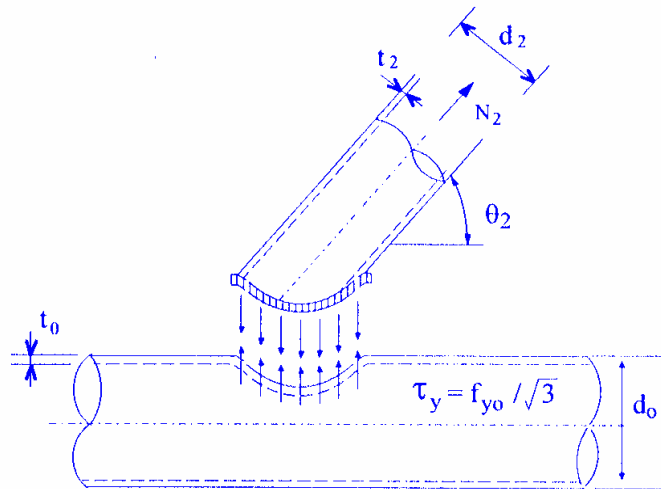

Figure 10.3 Model for punching shear failure of the chord in a CHS joint

Model for chord shear failure

As seen in Figure 10.4, for K and N joints with a gap between diagonals, the chord cross-section may collapse in the gap section, because of the combination of axial force, shear force and bending moment.

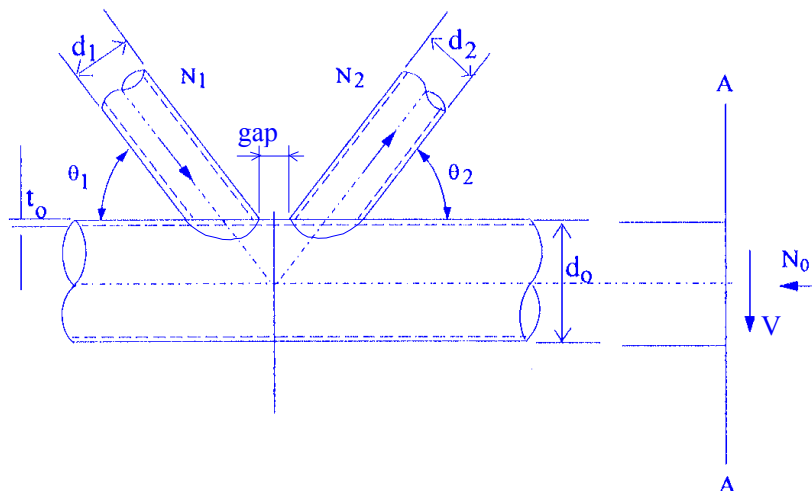

Figure 10.4 Model for chord shear failure in a CHS joint

If the chord is a compact section, plastic design gives the following relations:

$$N_i \sin \theta_i \leq 2 \frac{f_{yo}}{\sqrt{3}} (d_o - t_o) t_o, \quad (10.3)$$

$$N_{o,gap} \leq \pi (d_o - t_o) t_o f_{yo}, \quad (10.4)$$

$$M_{o,gap} \leq (d_o - t_o)^2 t_o f_{yo}. \quad (10.5)$$

Generally, the bending moments are quite small and only the interaction between the axial force and the shear force has to be considered

$$\left(\frac{N_{o,gap}}{\pi (d_o - t_o) t_o f_{yo}} \right)^2 + \left(\frac{N_i \sin \theta_i}{2 \frac{f_{yo}}{\sqrt{3}} (d_o - t_o) t_o} \right)^2 \leq 1,0. \quad (10.6)$$

If the gap is small, the diagonals stiffen the chord, which considerably increases the shear resistance.

Q&A 10.2 Rectangular Hollow Section Joints

What analytical models are used for calculating the resistance of RHS joints?

Analytical models are used to describe the behaviour of connections and to study the effect of the principal parameters. Taking into account all the parameters is difficult and too complicated. For these reasons, different simplified models are used. In combination with test results made in laboratories, these models have been used to establish the design equations.

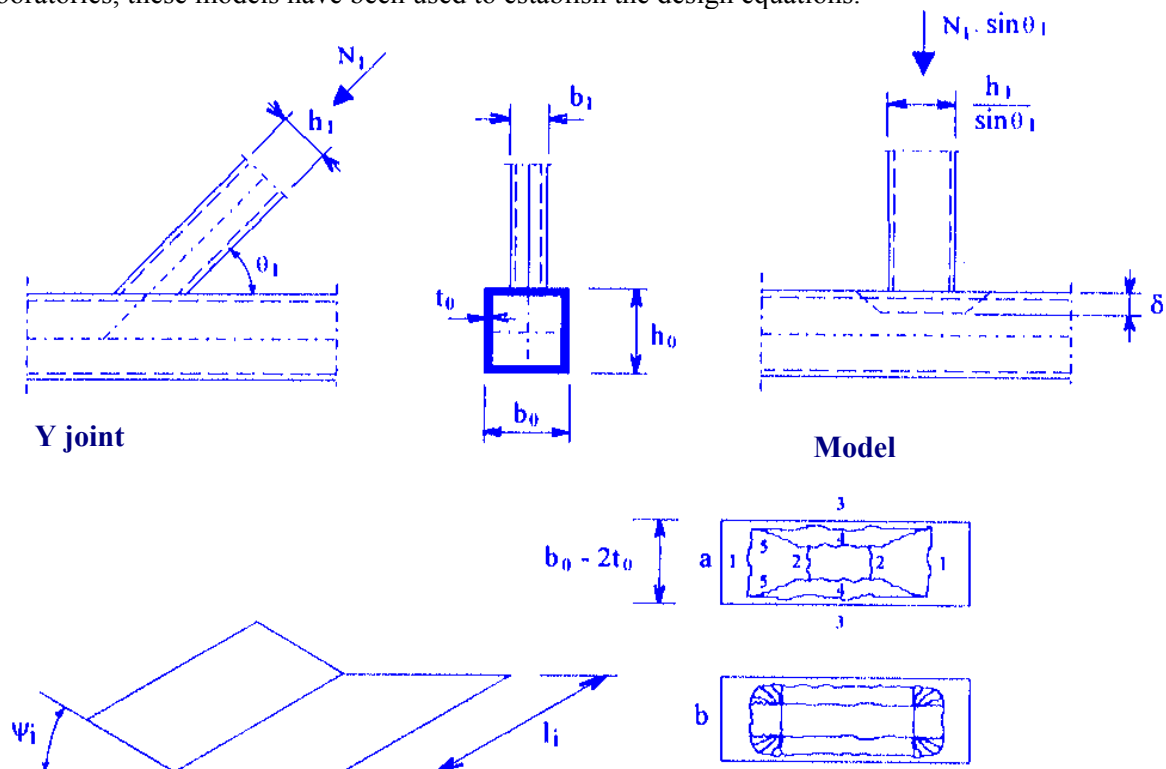

Figure 10.5 Plastic lines model for joints of type T, Y or X (chord face failure)

Plastic line model

The general principle of the model, illustrated in Figure 10.5, for an Y RHS joint, consists of equalising the work of the force N_l with a δ displacement, with the internal work in the plastic hinges (length l_i and rotation angle ψ_i . If θ_i is the angle between the brace and the chord, the capacity of the members [APK, 1996] obtained from the following expression

$$N_l = \frac{f_{yo} t_o}{1 - \beta} \left(\frac{2 h_l}{b_o \sin \theta_l} + 4 \sqrt{1 - \beta} \right) \frac{l}{\sin \theta_l}. \quad (10.7)$$

Model for brace punching shear failure

This model is presented in Figure 10.6 for a Y joint subject to tension. The shear resistance for T, Y and X joints is obtained by the formula

$$N_l = \frac{f_{yo}}{\sqrt{3}} t_o \left(\frac{2 h_l}{\sin \theta_l} + 2 b_{ep} \right) \frac{l}{\sin \theta_l}. \quad (10.8)$$

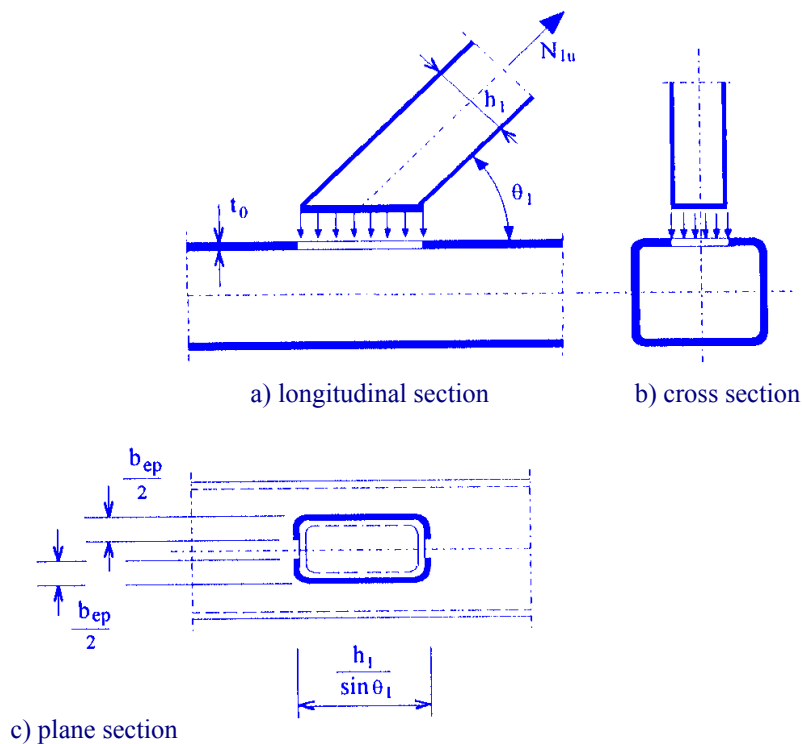

Figure 10.6 Plastic lines model for joints of type T, Y or X (chord face failure)

Model of the brace effective width

The resistance is calculated as a function of the brace dimensions, which for T, Y and X joints is

$$N_l = f_{yl} \cdot t_l \cdot (2 h_l - 4 t_l + 2 b_{eff}). \quad (10.9)$$

Model of chord shear failure

The shear resistance of the chord may be calculated analytically using the plastic design of the section:

$$V_{pl} = \frac{A_v f_{yo}}{\sqrt{3}}, \quad (10.10)$$

where $A_v = (2 h_0 + \alpha b_0) t_0$ and α is a function of g/t_0 . The rest of the chord section is taking the axial effort. Using the von Mises criterion of plasticity, the following interaction formula is obtained:

$$N_{o,gap,Sd} \leq (A_o - A_v) f_{yo} + A_v f_{yo} \sqrt{1 - \left(\frac{V_{Sd}}{V_{pl,Rd}} \right)^2}, \quad (10.11)$$

where V_{Sd} is the design shear effort and $V_{pl,Rd}$ is the plastic resistance to the shear effort of a section calculated with relation (10.10), divided by the safety partial factor γ_{M0} .

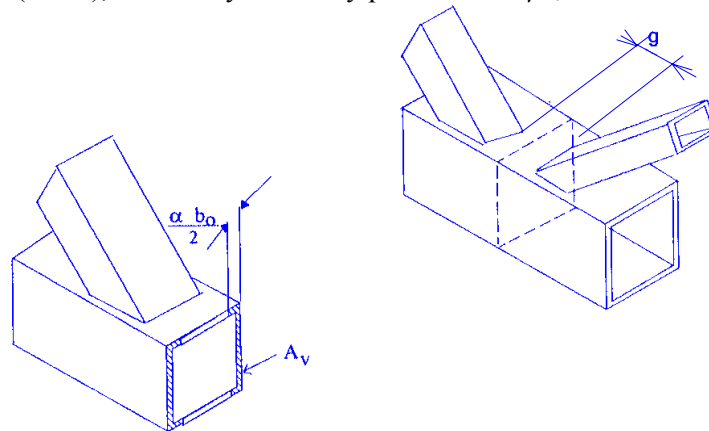

Figure 10.7 Model for RHS chord shear in the gap of K or N joint

Model for the plastification or the local buckling of the lateral chord side walls

T, Y and X joints, with a high level of β , may reach failure by the plastification or the local buckling of the lateral chord side walls. For RHS joints of the same width, the model presented in Figure 10.8 gives

$$N_l = 2 f_{yo} t_o \left(\frac{h_l}{\sin \theta_l} + 5 t_o \right) \frac{l}{\sin \theta_l}. \quad (10.12)$$

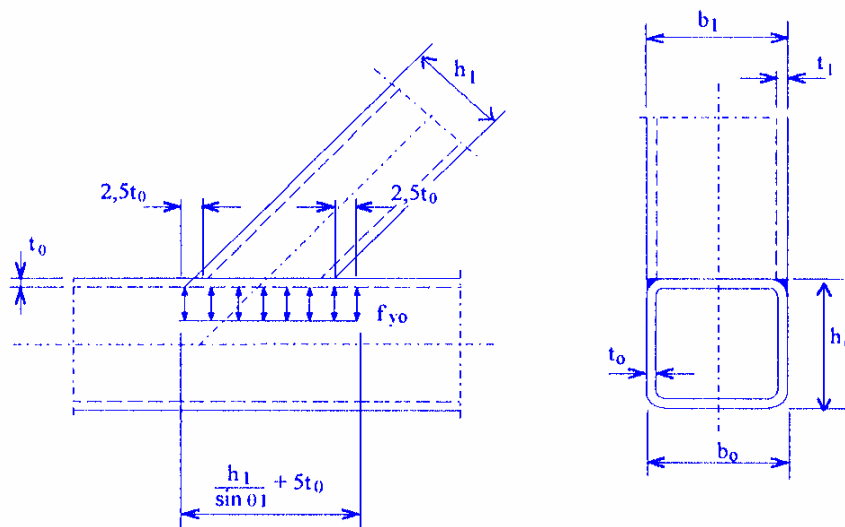

Figure 10.8 Model for the plastification or the local buckling of the lateral chord side walls

Q&A 10.3 Joints between Hollow and Open Section Members

What analytical models are used for connections between CHS or RHS members and I or H section chords?

The design resistance is calculated using simplified models which have been verified experimentally.

Model of the brace effective width

For joints made by hollow sections welded on I or H sections, there is an unequal distribution of the stresses and deformations at the end of a hollow member, due to the web and the different rigidity between the ends and the central part of the flange, see Figure 10.9. If the load is increasing, this phenomena is more important and may reach a premature failure of the joint, by the collapse between the member in tension and the chord flange, or by local buckling at the edge of the member in tension. To cover this risk of collapse, the term of transversal cracking is used commonly and the majority of authors have introduced the effective width. This term is representative for the perimeter of the hollow section, able to transmit the effort at the stage of the collapse, see Figure 10.10 [APK, 1996].

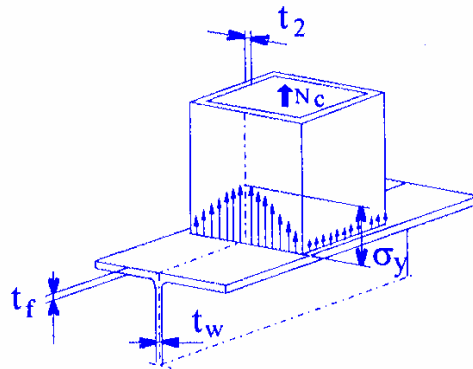

Figure 10.9 Distribution of the stresses and deformations at the end of a RHS member

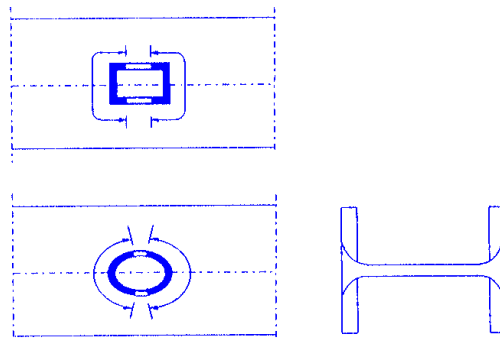

Figure 10.10 Notion of effective perimeter

The ultimate resistance of the member for T, Y, X, K and N (with gap) joints may be computed as follow:

$$N_{iRd} = 2 f_{yi} t_i b_{eff}, \quad (10.13)$$

where b_{eff} being equal with the half length of the effective part of the perimeter of the hollow member. The following formula may be used to compute b_{eff} :

$$b_{eff} = t_w + 2 r + 7 \frac{f_{yo}}{f_{yi}} t_f \quad (10.14)$$

Model of chord shear failure

The risk of failure by shear of the chord is the most probably failure mode for K and N connections with gap Figure 10.11.

The shear resistance of the chord could be computed using the following formula, where A_v represents the effective shear area:

$$V_{pl} = \frac{A_v f_{y0}}{\sqrt{3}} \quad (10.15)$$

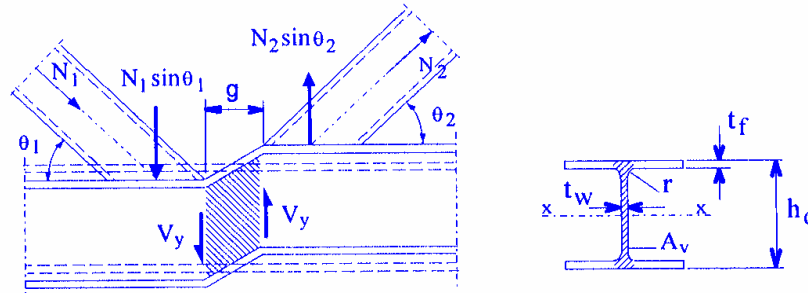

Figure 10.11 Shear of the chord in a K joint with gap

Model of the local plastification of the chord web

The approach of calculating the local plastification of the chord web in tension and the local crushing of the chord web is similar to that used to determine the local tension capacity of the web of the I and H section. The method is shown in Figure 10.12 and the resistance $N_{i,Rd}$ is given by the following expression

$$N_{i,Rd} = \frac{f_{y0} t_w b_w}{\sin \theta_i} \quad (10.16)$$

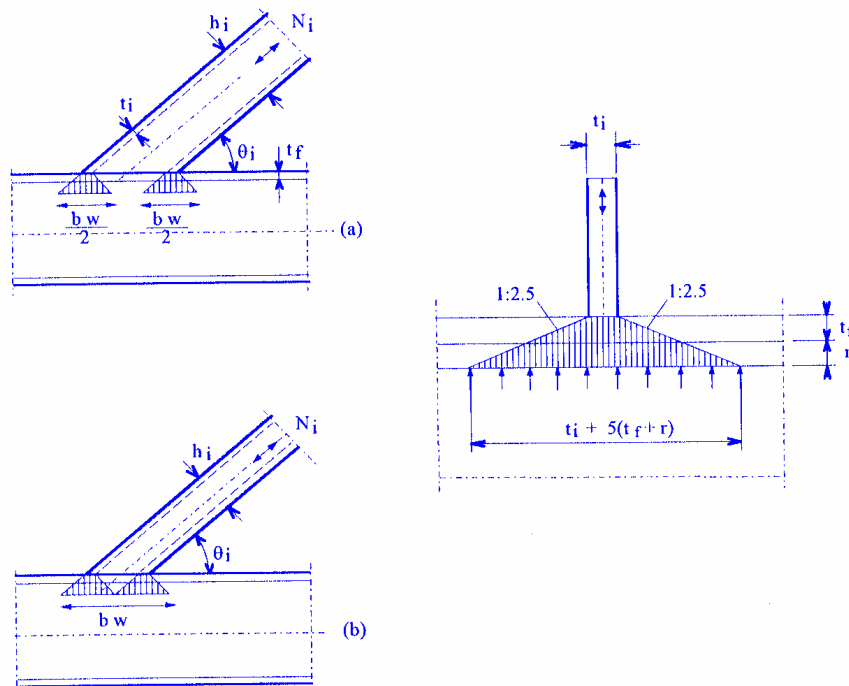

Figure 10.12 Local plastification of the chord web

Q&A 10.4 Design Charts

What is the background to the design charts?

The design charts shown in Figure 10.13 are based on the efficiency coefficient C_e of the brace [APK, 1996]. The efficiency coefficient is obtained by the following formula

$$\frac{N_{I,Rd}}{A_i f_{yI}} = C_e \frac{f_{yo} t_o}{f_{yI} t_I} \frac{k_p}{\sin \theta_I} \quad (10.17)$$

Efficiency parameter C_e (C_T for T and Y joints, C_X for X joints and C_K for K and N joints) means the efficiency of a joint with $k_p = 1,0$ and $t_I = 90$, with identical thickness and steel grade in braces and chord.

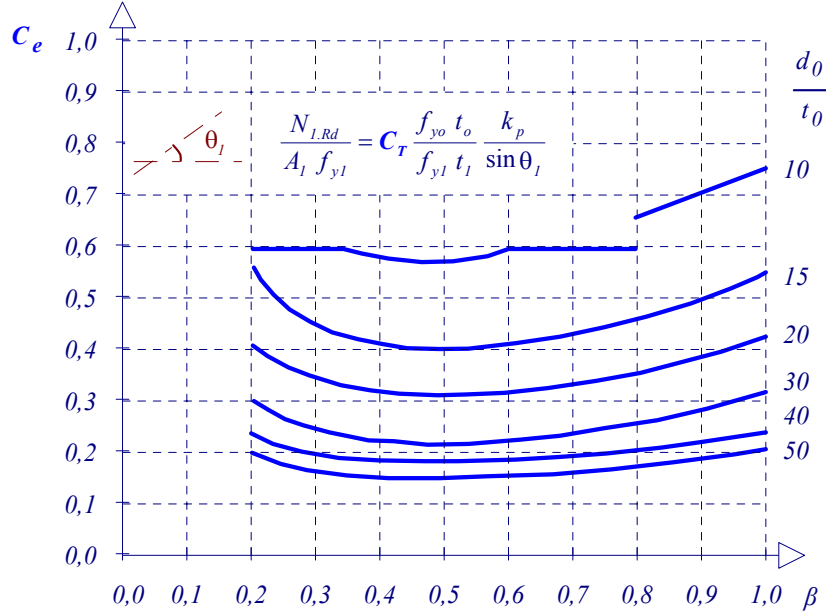

Figure 10.13 Design chart for T and Y joints of CHS sections

In practise, it is important to evaluate quickly the joint resistance of RHS sections, which may be made by design charts given for K, N, T, Y and X joints. These charts are based on the EN 1993-1-8 recommendations. The joint resistance is given by an efficiency coefficient C_e .

Generally, the efficiency is given by the following formula [APK, 1996]:

$$\frac{N_{I,Rd}}{A_i f_{yi}} = C_e \frac{f_{yo} t_o}{f_{yi} t_i} \frac{k_n}{\sin \theta_i} \quad (10.18)$$

For instance, Figure 10.14 presents the efficiency of a K gap joint, of RHS. For joints with no gap, the total efficiency is given in the chart from Figure 10.15. The reference [CIDECT, 1995] contains design charts related to all the types of RHS joints with gap or overlapped.

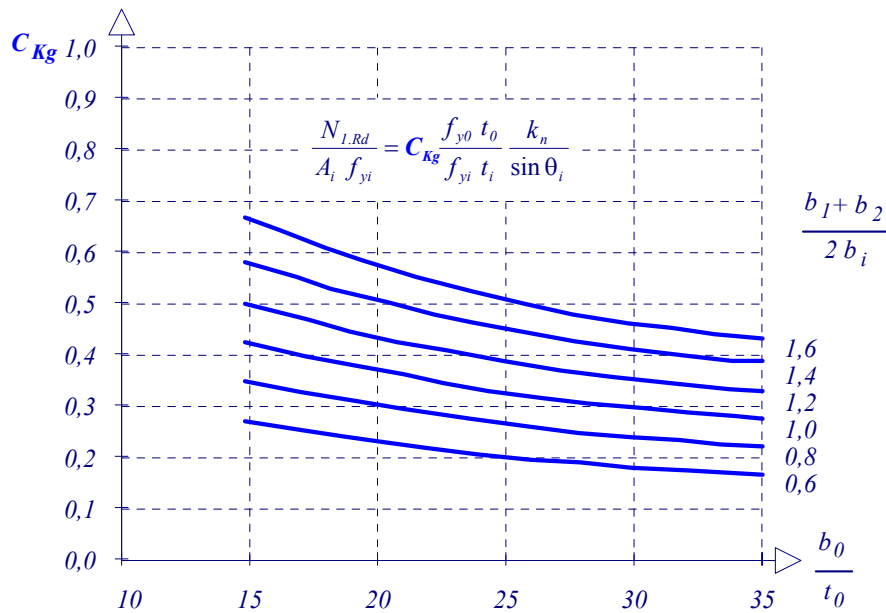

Figure 10.14 Chart of efficiency of braces for welded K and N RHS joints with gap

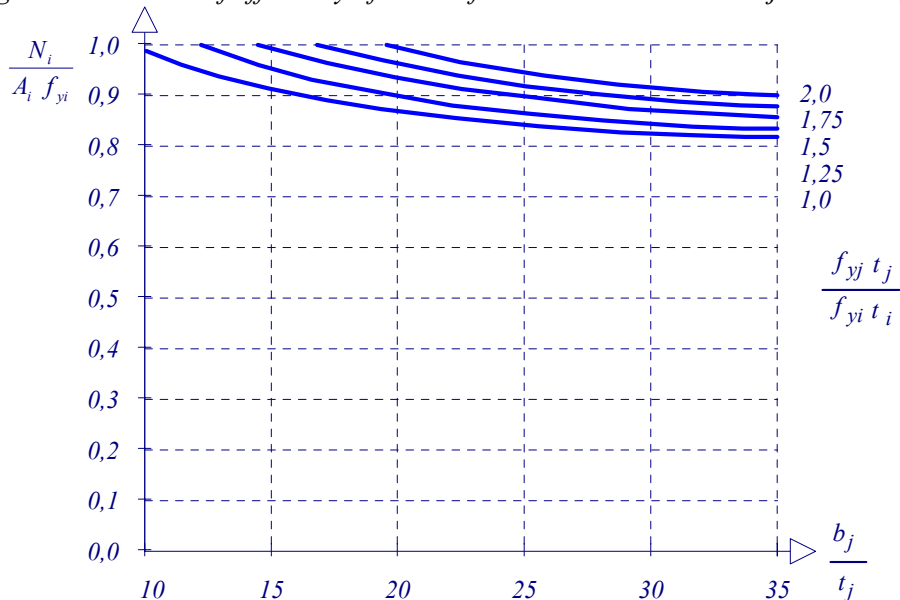

Figure 10.15 Chart of efficiency of braces for welded K and N RHS joints with no gap

Q&A 10.5 Blind Bolting

What different types of blind bolts are available?

Flowdrill Drill System

The Flowdrill system is a method for the extrusion of holes using a four lobed tungsten-carbide friction drill [Yeomans, 2002]. The process is shown schematically in Figure 10.16. A typical beam end plate connection is described in Figure 10.17. The results of a series of tests on individual flow-drilled holes and on connections made using the Flowdrill system have shown that they are suitable for structural applications [Korol et al, 1993] and [Ballerini et al, 1996]. These tests have shown that:

- holes can be produced in sections from 5,0 to 12,5 mm thick, [Barnett et al, 2001],

- threaded roll tapped holes with M16, M20 and M24 ISO course thread profiles can be made. If the threads are made using a standard cutting tap the pull-out capacities will be lower than those shown in Table 10.1,
- the full tension capacity of grade 8.8 bolts can be carried by flow-drilled and roll tapped holes, provided that the material thickness is equal to or greater than the minimum thickness shown in Table 10.1 and the material has a nominal yield strength in the range 275 to 355 MPa,
- the shear and bearing capacities of the hole and bolt can be calculated in the normal manner.

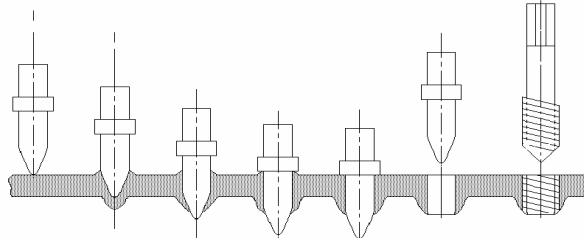

Figure 10.16 Schematic of the Flowdrill process

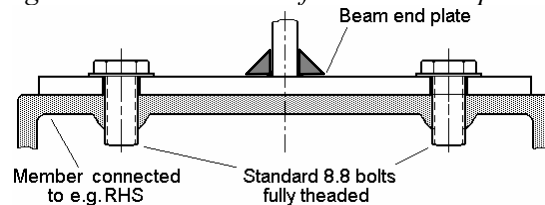

Figure 10.17 Beam/column connection

Table 10.1 Minimum material thickness for full grade 8.8 bolt tension capacity

Bolt size and grade	Minimum material thickness, mm
M16 grade 8.8	6.4
M20 grade 8.8	8.0
M24 grade 8.8	9.6

Lindapter HoloBolt Insert

The HoloBolt is a three part pre-assembled unit consisting of a main body, a threaded truncated cone and a standard grade 8.8 bolt and is shown in Figure 10.18a, a five-parts system is also available [Yeomans, 2002].

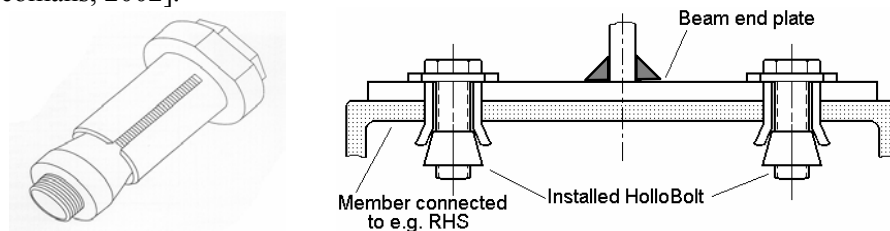

Figure 10.18 a) Insert (as supplied), b) beam/column connection

Huck Ultra-Twist Bolt

The Ultra-Twist bolt is a pre-assembled unit [Yeomans, 2002]. An exploded view of the bolt is shown in Figure 10.19a. The Ultra-Twist bolt is installed using an electric bolting wrench in holes 2 mm larger than the outside diameter of the bolts, which provides conventional clearances for fit-up, Figure 10.19b.

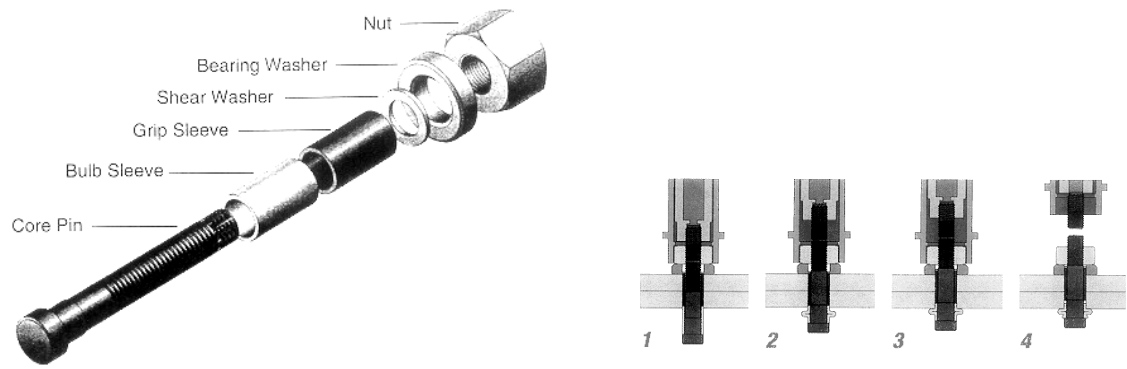

Figure 10.19 Huck Ultra-Twist bolt, a) exploded view of the bolt, b) installation procedure

Stud Welding

Threaded studs welded to steel columns can also be used to produce connections. A typical beam end plate connection, without counter sunk holes is shown in Figure 10.20 [Maquoi et al, 1984].

Welded nuts

There are several other methods available for making bolted connections, which can be fixed from one side only [Sadri, 1994]. Two of these are briefly described below. The first method is simply drilling and tapping the steel section, but this generally needs a wall thickness of 16 mm or more to generate enough pull out capacity. Another method [Kato, 1988], is to drill holes in the steel section large enough for a nut of the required size to be inserted and then to weld the nut to the steel section flush with the outside surface, see Figure 10.21.

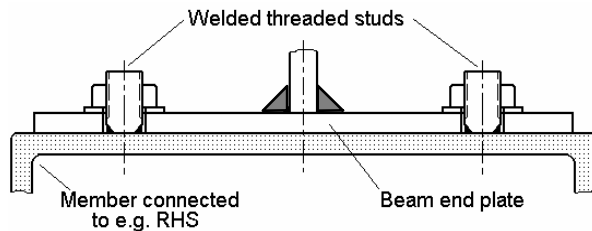

Figure 10.20 Welded threaded stud connection

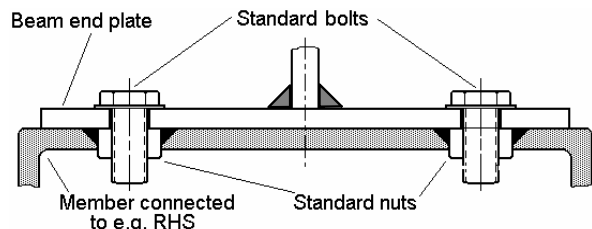

Figure 10.21 Nuts welded into hollow section wall

Q&A 10.6 Hollow Section Joints using High Strength Steel

Can the rules given in prEN 1993-1-8 be applied to high strength steels?

The rules given in prEN 1993-1-8 may be applied to high strength steels. Clause 7.1.1 (4) specifies that nominal yield strength of hot finished hollow sections and the nominal yield strength of the basic material of cold formed hollow sections should not exceed 460 MPa . For grades S 420 and S 460 the static resistances given in this section should be reduced by a factor $0,9$. According to EN 10210 and EN 10219 the requirements for material is determined based on the end product, not on the base material.

CIDECT Design Guide [CIDECT, 1995] stipulates that it is possible for structural hollow sections in special steels to be produced, e.g. very high strength steels with yield strengths up to 640 MPa or higher, weathering steels and steels with improved or special chemical compositions, etc.; often large quantities would require to be ordered [Oyj, Vainio, 2000].

Q&A 10.7 Offshore Construction

Can the recommendations in prEN 1993-1-8 be applied to the large sections used in offshore construction?

The field of application of hollow sections in engineering is large and their specific domains of application are listed in [CIDECT, 1995] including offshore structure. The design rules of prEN 1993-1-8: 2003, Chapter 7 could be used in the case of offshore structures, provided the general conditions are fulfilled. In the case of offshore structures these limits of applications are mostly not fulfilled and special requirements must be used. In addition fatigue design conditions need to be considered.

- threaded roll tapped holes with M16, M20 and M24 ISO course thread profiles can be made. If the threads are made using a standard cutting tap the pull-out capacities will be lower than those shown in Table 10.1,
- the full tension capacity of grade 8.8 bolts can be carried by flow-drilled and roll tapped holes, provided that the material thickness is equal to or greater than the minimum thickness shown in Table 10.1 and the material has a nominal yield strength in the range 275 to 355 MPa,
- the shear and bearing capacities of the hole and bolt can be calculated in the normal manner.

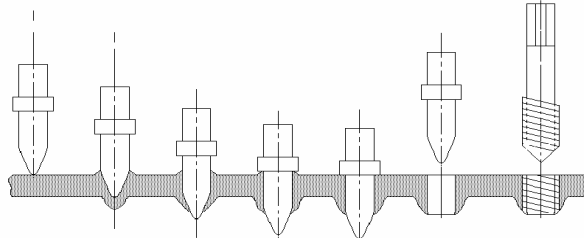

Figure 10.16 Schematic of the Flowdrill process

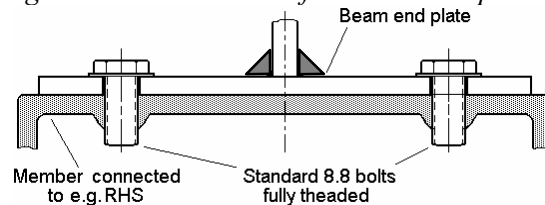

Figure 10.17 Beam/column connection

Table 10.1 Minimum material thickness for full grade 8.8 bolt tension capacity

Bolt size and grade	Minimum material thickness, mm
M16 grade 8.8	6.4
M20 grade 8.8	8.0
M24 grade 8.8	9.6

Lindapter HoloBolt Insert

The HoloBolt is a three part pre-assembled unit consisting of a main body, a threaded truncated cone and a standard grade 8.8 bolt and is shown in Figure 10.18a, a five-parts system is also available [Yeomans, 2002].

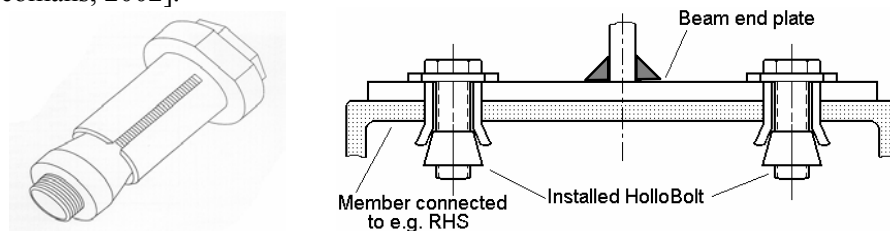

Figure 10.18 a) Insert (as supplied), b) beam/column connection

Huck Ultra-Twist Bolt

The Ultra-Twist bolt is a pre-assembled unit [Yeomans, 2002]. An exploded view of the bolt is shown in Figure 10.19a. The Ultra-Twist bolt is installed using an electric bolting wrench in holes 2 mm larger than the outside diameter of the bolts, which provides conventional clearances for fit-up, Figure 10.19b.

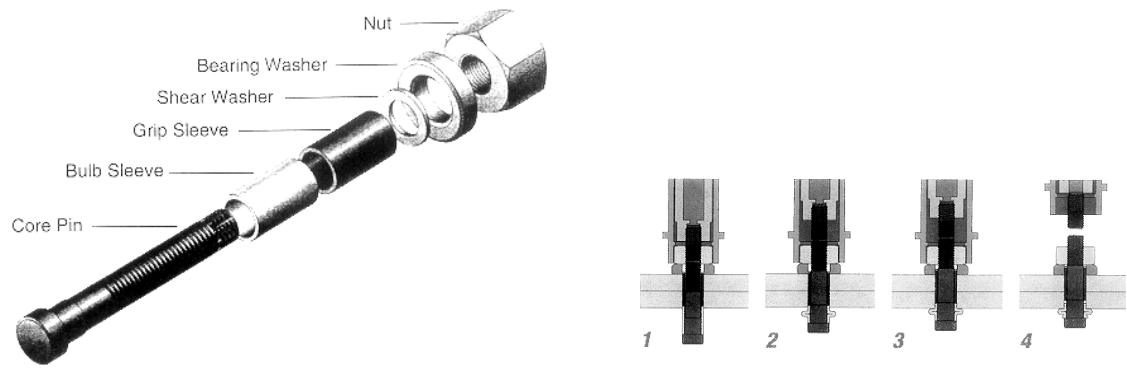

Figure 10.19 Huck Ultra-Twist bolt, a) exploded view of the bolt, b) installation procedure

Stud Welding

Threaded studs welded to steel columns can also be used to produce connections. A typical beam end plate connection, without counter sunk holes is shown in Figure 10.20 [Maquoi et al, 1984].

11 COLD-FORMED CONNECTIONS

11.1 Connections

A variety of joining methods is available for thin-walled structures. In comparison with thicker connections ($t > 3 \text{ mm}$) the behaviour of connections in thin-walled elements is characterised by the small plates stiffness [Davies, 1991]. Therefore, additional effects may appear in the ultimate limit state and serviceability state and the level of safety may be more depend on the quality control. Such effects are, for example, the tilting of the fastener in hole bearing failure or the big distortion of the sheet when the fastener is loaded in tension and the sheet is pulled over the head of the fastener. This is the reason why design procedures for connections in cold-formed elements have been developed which are, in a number of cases, different from the procedures for thicker steel. Connections to thin walled members are used for:



- connecting steel sheets to the supporting structure, e.g. to a purlin;
- interconnecting two or more sheets, e.g. longitudinal seams of sheets;
- assemble linear cold-formed sections, e.g. in storage racking.

11.2 Fastenings

For thin-walled constructions three types of fastenings can be identified [Toma et al, 1993] and [Yu, 2000]:

- fastenings with mechanical fasteners;
- fastenings based on welding;
- fastenings based on adhesive bonding.

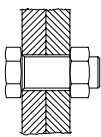
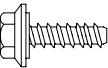
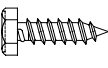
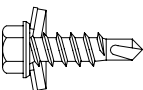
Table 11.1 Global survey of application field for mechanical fasteners

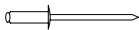
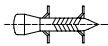
Thin to thick	Steel to wood	Thin to thin	Fastener	Remark
X		X		Bolts M5-M16
X				Self-tapping screw ϕ 6,3 with washer $\geq 16 \text{ mm}$, 1 mm thick with elastomer
	X	X		Hexagon head screw ϕ 6,3 or 6,5 with washer $\geq 16 \text{ mm}$, 1 mm thick with elastomer
X		X		Self-drilling screws with diameters: ϕ 4,22 or 4,8 mm ϕ 5,5 mm ϕ 6,3 mm
X				Thread-cutting screw ϕ 8 mm with washer $\geq 16 \text{ mm}$, 1 mm thick with or without elastomer
				Blind rivets with diameters: ϕ 4,0 mm ϕ 4,8 mm ϕ 6,4 mm
X				Shot pins

Mechanical fasteners

Table 1 shows a global field of application of the different mechanical fasteners according to Toma [Toma et al, 1993]. In the following part some short information is given concerning the different mechanical fasteners. Bolts with nuts are threaded fasteners, which are assembled in preformed holes through the material elements to be joined [Hancock, 1998]. Thin members will necessitate the use of bolts threaded close to the head [Wong, Chung, 2002]. For thin-walled sections the bolt diameter is usually M5-M16. The preferred property classes are 8.8 or 10.9. Results of tests indicate that the following four basic types of failure usually occur [Fan, 1995] in the cold-formed steel bolted connections:

- longitudinal shearing of the sheet along two parallel lines, see Figure 11.1a;
- bearing or piling up of material in front of the bolt, see Figure 11.1b;
- tearing of the sheet in the net section, see Figure 11.1c;
- shearing of the bolt, see Figure 11.1d.

In many cases, a joint is subject to a combination of different types of failure. The tearing of the sheet is often caused by the excessive bolt rotation and dishing of the sheet material. Screws can provide a rapid and effective means to fasten sheet metal siding and roofing to framing members and to make joints in siding and roofing, as shown in Figure 11.2. They can also be used in steel framing systems and roof trusses and to fasten drywall panels to metal channels and runners. Two main types of screws can be distinguished:

- self tapping screws, i.e. thread-forming screws and thread-cutting screws,
- self-drilling screws.

Most of the screws will be combined with washers to improve the load-bearing capacity of the fastening and/or to make the fastening self-sealing. Some types have plastic heads or plastic caps are available for additional corrosion resistance and colour matching.

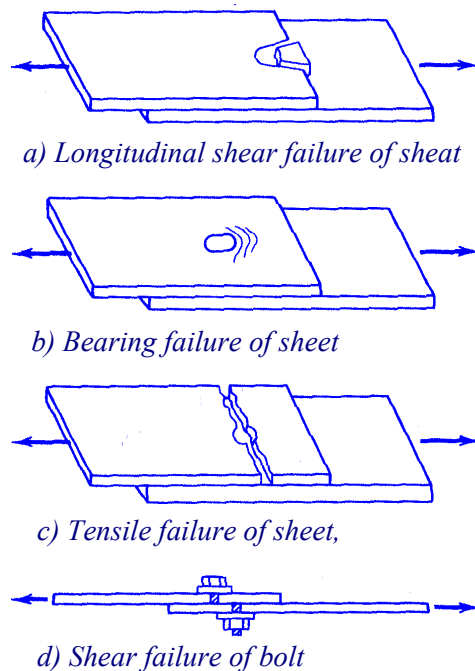

Figure 11.1 Failures of bolted connections

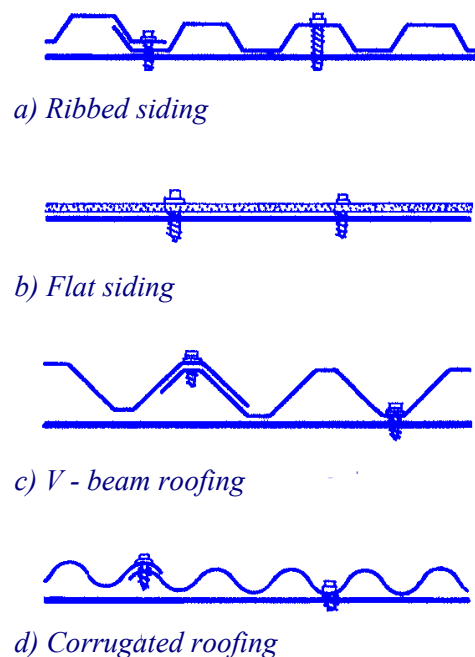

Figure 11.2 Application of self-tapping screws

Figure 11.3 shows the thread types for thread-forming screws. Type A is used for fastening thin-to-thin sheets. Type B is used for fixings to steel base of a thickness greater than 2 mm. Type C is usually used for fixings to thin steel bases of a thickness up to 4 mm. Thread-forming screws normally are fabricated from carbon steel (plated with zinc and lubricant).

Figure 11.4 shows some examples of thread and point of thread-cutting screws. Thread-cutting screws are used for fastening to thicker metal bases. Self-drilling screws drill their own hole and form their mating thread in one operation. Figure 11.5 shows two examples of self-drilling screws.

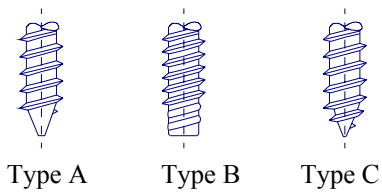

Figure 11.3
Thread types for thread-forming screws

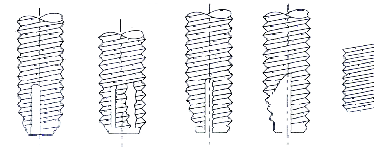

Figure 11.4
Thread and point of thread-cutting screws

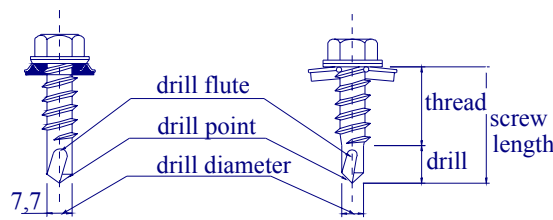

Figure 11.5 Examples of self-drilling screws

Blind rivets and tubular rivets are often used in cold-formed steel construction [Kaitila et al, 2001]. They are used to simplify assembly, improve appearance, and reduce the cost of connection. A blind rivet is a mechanical fastener capable of joining work pieces together where access to the assembly is limited to one side only. Based on the method of setting, blind rivets can be classified into

- pull-stem rivets, see Figure 11.6;
- explosive rivets (with a chemical charge in the body, which is expanded by applying heat to the rivet head),
- drive-pin rivets (two-piece rivets, which consist of a rivet body and a separate pin installed from the head side of the rivet).

Tubular rivets are often used to fasten sheet metal. The strength in shear or compression is comparable to that of solid rivets. Nominal body diameters range from 0,8 to 7,9 mm. The corresponding minimum lengths range from 0,8 to 6,4 mm.

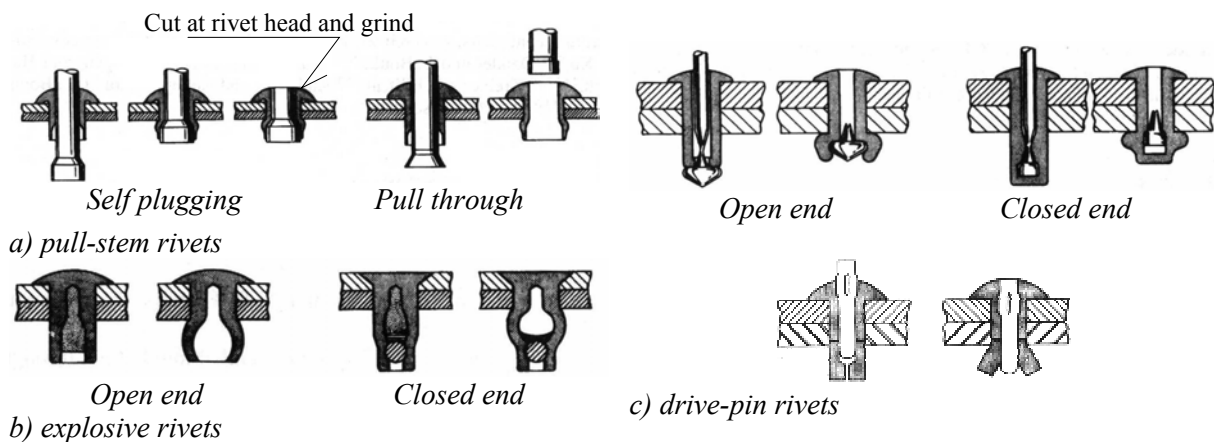

Figure 11.6 Blind rivets

Shot pins, examples are shown in Figure 11.7, are fasteners driven through the connecting plate into the base metal by powder shot or by air.

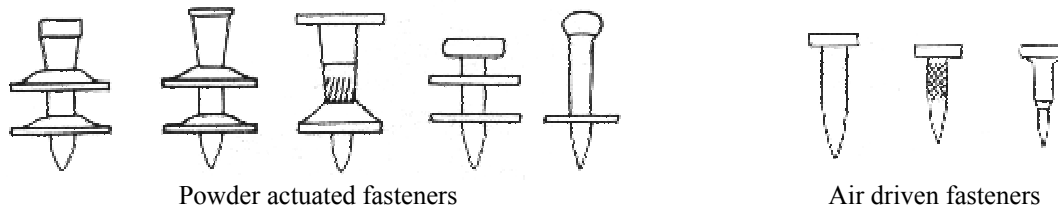

Figure 11.7 Shot pins

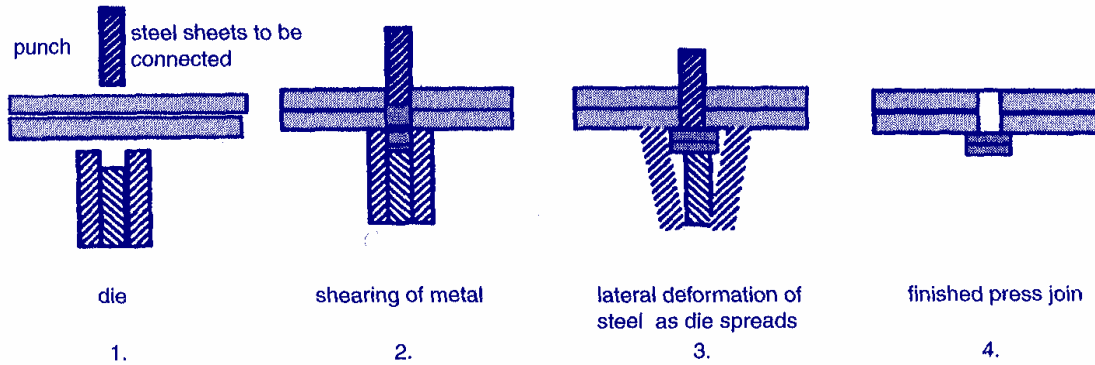

Figure 11.8 Sequence of forming press-joint

Press joining is a relatively new technique for joining cold-formed steel sections. The joint is formed using the parent metal of the sections to be connected [Kolari K., 1999]. The tools used to form a press-joint consist of a male and female punch and die. Figure 11.8 shows the sequence of forming a press-joint.

Rosette-joining, see Figure 11.9, is also a new automated approach for fabricating cold-formed steel components such as stud wall panels and roof trusses. It is formed in pairs between prefabricated holes in one jointed part and collared holes in the other part. The joining process is shown in Figure 11.9.

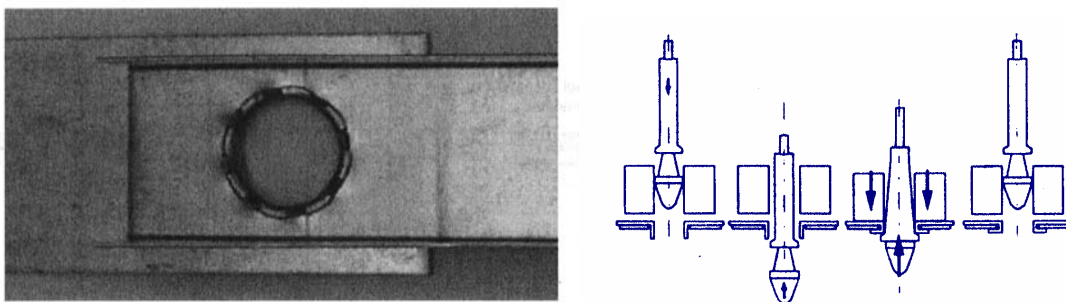

Figure 11.9 Rosette-joint and rosette-joining process [Makelainen et al, 1999]

Welding

Cold-formed sections joints can be made by the open arc process as well as by resistance welding. The following welding procedures are used for thin-walled sections, see [Toma et al, 1993]:

- GMA – welding (gas metal arc welding),
- manual arc welding (welding with covered electrodes),
- TIG welding (tungsten-inert gas welding),
- plasma welding.

The following types of arc welds are generally used in cold-formed steel constructions, see Figure 11.10 [Yu, 2000]:

- groove welds,
- arc spot welds (puddle welds),
- arc seam welds,
- fillet welds,
- flare groove welds.

Resistance welding is done without open arc. In contrary to the open arc welding process there is no need of protection of the molten metal by shielding gas slag. Figure 11.11 demonstrates the resistance welding procedures.

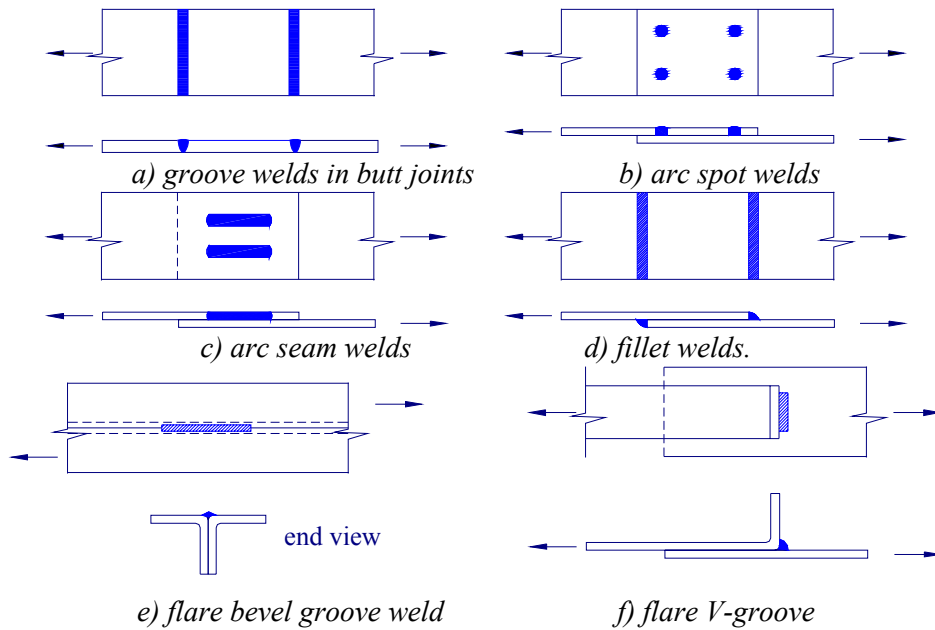

Figure 11.10 Arc welds

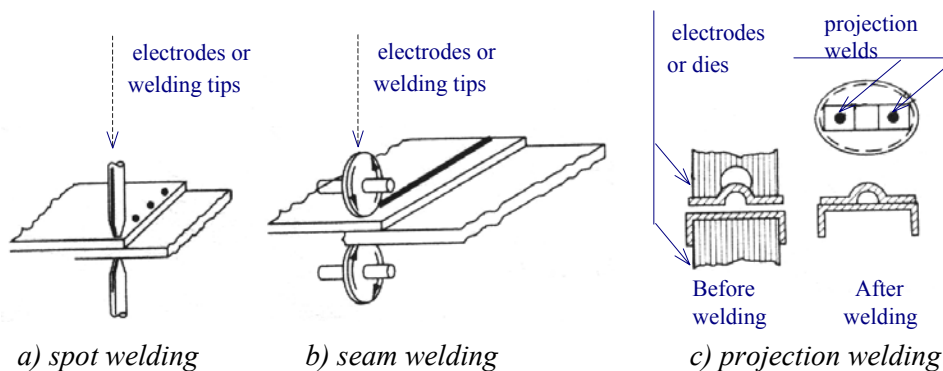

Figure 11.11 Resistance welding procedures

Adhesive bonding

For fastening by means of bonding it is important to realise that a bonded connection possesses a good shear resistance and mostly a bad peeling resistance, see Figure 11.12. For that reason a combination of bonding and mechanical fastening may be chosen. Adhesives used for thin walled steels are as follows:

- epoxy adhesive types – best hardening will appear under elevated temperature (order of magnitude 80-120°C);
- acrylic adhesive types – more flexible than the epoxy types.

Advantages of bonded connections are a uniform distribution of forces over the connection and a good repeated load behaviour. Some disadvantages are that the surface should be flat and clear and there is a hardening time.

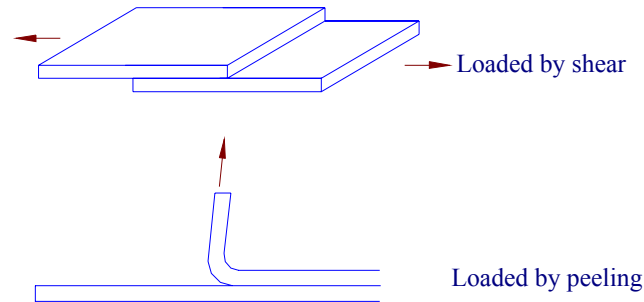

Figure 11.12 Shear and peeling of connections by means of adhesive bonding

11.3 Design considerations

Design considerations for cold-formed members are specified in Chapter 8 of standard prEN 1993-1-3 [prEN 1993-1-3, 2003]. Concerning the Mechanical fastenings, it has to underline that bearing resistance, shearing resistance, tension resistance and net section resistance of connected members are calculated in the same way as for thick sections, for any type of connector. There are differences at the numerical coefficients from formulas, which are specified by the standard. Specific failure modes are checked for the pull through and pull out resistance. Connections with mechanical fasteners are treated in paragraph 8.4 of the norm like blind rivets (Table 8.1), self-tapping screws (Table 8.2), cartridge fired pins (Table 8.3) and bolts (Table 8.4). Concerning the welded connections, spot welds represent a fastening technology, which is specific for thin walled metal structures and specific design provisions have been developed. They are specified in Eurocode 3-1-3. Design resistances for spot welds connections are given in paragraph 8.5, Table 8.5, while for lap welds in paragraph 8.6, with fillet welds in (8.6.2) and arc spot welds in (8.6.3), respectively. Specifications for connections based on adhesive bonding are included in the standard for aluminium structures ENV 1999-1. Special mechanical connections, press- and rosette-joints are in the same situation and they have to be treated in the same way as the previous ones. When design by testing is used, provisions of ENV 1993-1-3, Chapter 9 and Annex Z of ENV 1993-1-3 has to be used.

Q&A 11.1 Increased Yield Strength by Cold-Forming

Can the increase in yield strength due to cold working be utilized in the design of connections that are welded after the member is formed?

In the design formula for the weld strength in prEN 1993-1-3, however, the strength parameter for the material is the ultimate strength f_u of the plate material, which is not influenced by cold forming. It is noted that due to the heat input during welding, the increased yield strength near the welds disappears, which means that at those cross sections no positive effect of the cold forming is allowed to be taken into account.

Q&A 11.2 Deformation Capacity of Shear Connections

Why is the limit $F_{v,Rd} \geq 1,2 F_{u,Rd}$ in the standard prEN 1993-1-3?

This question refers to prEN 1993-1-3, Table Design resistance for self-tapping screws. The design criterion for shear deformation capacity of connection is expressed as:

$$F_{v,Rd} \geq 1,2 F_{n,Rd} \quad (11.1)$$

where $F_{v,Rd}$ is the shear resistance, see Figure 11.1, or evaluated by testing and

$$F_{n,Rd} = \frac{A_{net} f_u}{\gamma_{M2}} \quad (11.2)$$

is the net section resistance.

The multiplier $1,2$ in formula (11.1) is to ascertain that the failure mode of the connection is bearing or net section failure and not failure of the screw. Failure of the screw gives brittle behaviour of the connection, because of the small deformation capacity of the screw in shear [LaBoube, Yu, 1999].

The factor $1,2$ is taken into account the possible unfavourable mechanical properties of the steel compared to the screw (the real strength of the steel may be much higher than the nominal value, while the strength of the screw may be just the nominal value). The required conditions should be fulfilled when deformation capacity of the connection is needed. When these conditions are not fulfilled it should be proved that the required deformation capacity will be provided by other parts of the structure.

Q&A 11.3 Screws in Sandwich Panels

How is the resistance of bolts in sandwich panels subject to shear and tension evaluated?

Self-tapping screws are used to connect sandwich panels [prEN 14509, 2002]. The loading by temperature, wind and dead load is mostly cyclic. The screws of austenitic steels with special shapes are used to prevent the fracture under serviceability loading, see 11.13a. The flexibility of the structure (stress skin method) is taken into account to prevent the collapse under loading by the differences of temperature [Davies, 1986] and [De Matteis, Landolfo, 1999]. The distribution of forces into the internal and external plate of the sandwich panel may be taken into account using the component method, see 11.13b [Mareš et al, 2000]. Two failure modes of bolted connection of sandwich panel were observed the bearing in the internal hole, see Fig. 11.14a, and the fracture of the screw shank, see Fig. 11.14b. By the horizontal loading of panels the membrane forces due to deflection of sandwich panel, see [ECCS 66, 2000], are taken into account including the prying forces caused by additional fixing moments, see Fig. 11.14c,.

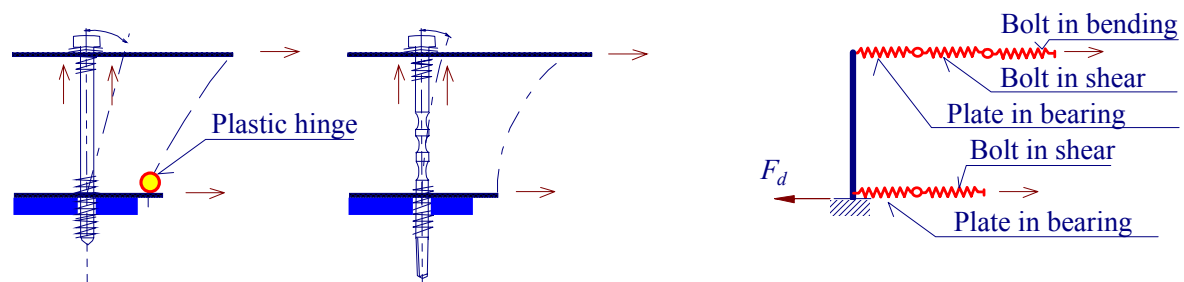

a) deflection curve of traditional screw and of screw with notches on shank

b) component model of bolt in sandwich panel [Mareš et al, 2000]

Figure 11.13 Bolted connection of sandwich panel

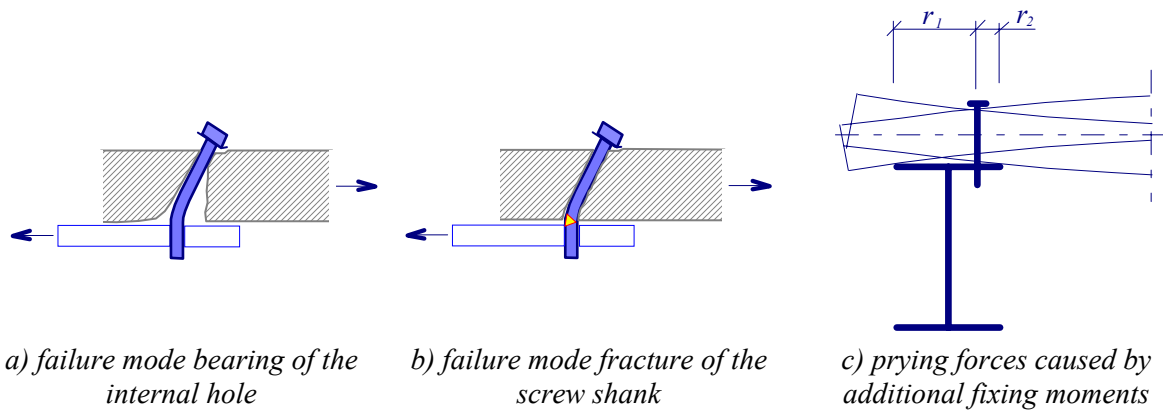

Figure 11.14 Bolted connection of sandwich panel

Q&A 11.4 Bearing of Thin Plates

What is the difference between the bearing resistance of thick and of thin (thin walled) plates?

The prediction models for the bearing resistance are based on the experimental evidence. The formula for bolts in thick plates (for thickness larger or equal to 3 mm) is included in Table 3.4 of prEN1993-1-8 and for bolts in thin plates in Table 8.1 of prEN 1993-1-3, where rivets, self tapping screws and pins are also included. The bearing resistance of thick plates takes into account the spacing into the perpendicular direction, by using the factor k_1 ,

$$F_{b,Rd} = \frac{k_1 \alpha_b f_u d t}{\gamma_{M2}}, \quad (11.3)$$

where α_b is the smallest of α_d ; f_{ub}/f_u or 1,0. In the direction of load transfer for end bolts $\alpha_d = e_1/(3 d_0)$ and for inner bolts $\alpha_d = p_1/(3 d_0) - 0,25$. Factor k_1 is for edge bolts the smallest of 2,8 (e_2/d_0) - 1,7 or 2,5 and for inner bolts the smallest of 1,4 (p_2/d_0) - 1,7 or 2,5. e_1 , e_2 , p_1 , p_2 are end distance, edge distance and spacing for fasteners. d_0 is diameter of the hole, d is the bolt diameter and t is the sum of thickness of connected plates in the checked direction. The bearing resistance of thin plates uses the factor k_t to take into account the thinners of the plate,

$$F_{b,Rd} = \frac{2,5 \alpha_b k_t f_u d t}{\gamma_{M2}}, \quad (11.4)$$

where α_b is smallest of $\alpha_b = e_1/(3 d)$ and $\alpha_b = 1,0$; while k_t for $0,75 \text{ mm} \leq t \leq 1,25 \text{ mm}$ is $k_t = (0,8 t + 1,5) / 2,5$ and for $t > 1,25 \text{ mm}$ is $k_t = 1,0$. The resistance for the thickness beyond this range of validity is determined from the tests.

12 ALUMINIUM CONNECTIONS

In the past decades, a large number of studies have been carried out to enlarge our knowledge on the behaviour of aluminium structures. One of the main research areas was on connections between aluminium structural members (bolted, welded and adhesive bonded connections) [Bulson, 1992]. All the results of these research efforts have been incorporated into Eurocode 9 [ENV 1999-1-1, 1999], which includes specifications and rules for the design of aluminium structures. In the design of mechanical fasteners the limited ductility of basic material needs to be taken into account. For friction grip bolted joints the transfer of forces is affected by the relaxation of the aluminium. Bolts of austenitic steel are used to avoid the risks of corrosion.

As far as the welding of aluminium structural members is concerned, welded connections have been widely established and developed and is an important joining method [Dwight, 1999]. The welds do not limit ductility of the connection, this being a great advantage compared to bolted and riveted connections [Mazzolani, 1995]. The design of welded connections is based on a method and assumptions similar to the ones used for steel structures with necessary modifications. The instructions for welding provided in Eurocode 9 [ENV 1999-1-1, 1999] can be used when the following requirements are satisfied:

- The structures are loaded with predominantly static loads,
- The welding process MIG (Metal Inert Gas) can be used for all thickness, while TIG (Tungsten Inert Gas) is being used only for material thickness up to $t = 6 \text{ mm}$ and for repair, and
- The welding consumables should correspond to the aluminium alloy of the connecting members. The choice of filler metal has a significant influence on the strength of the weld metal, being usually lower strength than the strength of the basic material, see Table 12.1.

Table 12.1 Characteristic strength values of the weld metal f_w [MPa]

Filler metal	Alloy							
	3103	5052	5083	5454	6060	6061	6082	7020
5356	-	170	240	220	160	190	210	260
4043A	95	-	-	-	150	170	190	210

According to Chapter 6.6.1, a higher partial safety factor of $\gamma_M = 1,65$ (instead $\gamma_M = 1,25$) should be used, if a lower quality level of welding has been specified by the designer for partial or non-strength members. Special care must be taken where aluminium structural connections are subjected to frequently fluctuating service loads leading to fracture due to fatigue. The basis for the design of such aluminium connections with respect to the limit state of fatigue induced fracture is presented in the ENV 1999-2.

Q&A 12.1 Resistance of Fillet Welds

In the calculation of a fillet weld, what stresses need to be checked so that the demands of Eurocode 9 are satisfied?

The approach that has to be followed is similar to the one presented in Chapter 3. The stresses in a fillet weld, see Figure 12.1, can be decomposed into stress components in the most critical section at the weld throat.

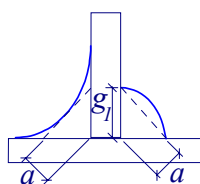

Figure 12.1 Thickness of the fillet weld throat, effective thickness

The stress components are the following, see Figure 12.12:

- σ_{\perp} the normal stress perpendicular to the critical plane of the throat,
- $\sigma_{//}$ the normal stress parallel to the axis of the weld, it should be neglected for design resistance of the fillet weld,
- τ_{\perp} the shear stress (in the critical plane of the throat) perpendicular to the weld axis,
- $\tau_{//}$ the shear stress (in the critical plane of the throat) parallel to the weld axis.

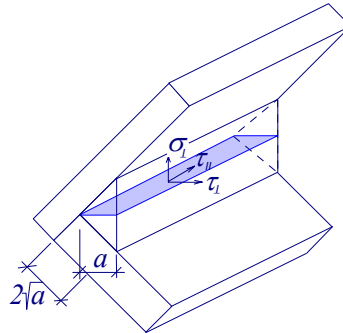

Figure 12.2 Stress components in a fillet weld

The resistance of the fillet weld is sufficient if both the following conditions are satisfied:

$$\sqrt{\sigma_{\perp}^2 + 3(\tau_{\perp} + \tau_{//})^2} \leq \frac{f_w}{\gamma_{Mw}} \quad (12.1)$$

and

$$\sigma_{\perp} \leq \frac{f_w}{\gamma_{Mw}} \quad (12.2)$$

Q&A 12.2 Effective Width and Throat Thickness of Fillet Welds

What are the geometrical restrictions, concerning effective width and the throat thickness, when using fillet welding?

The effective width of the fillet weld should be at least eight times the throat thickness a . The maximum length is limited by $100 a$. When the length is larger, effective length of the weld $L_{w,eff}$ is used instead, which can be calculated as

$$L_{w,eff} = \left(1,2 - 0,2 \frac{L_w}{100 a} \right) L_w \quad (12.3)$$

This reduction is used only in cases when stress in the welds of overlapping connection is not uniformly distributed, but reaches higher values at its ends, see Figure 12.3a. Uniform stress distribution can be achieved by proper shape of the connected parts, see Figure 12.3b.



a) non-uniform stress distribution b) modification for uniform stress distribution

Figure 12.3 Stress distribution in welded overlapping joints with fillet welds

Throat thicknesses of double sided fillet weld loaded perpendicularly to the weld axis, see Figure 12.4, should satisfy the following condition

$$a > 0,7 \frac{t \sigma \gamma_{Mw}}{f_w}, \quad (12.4)$$

where

$$\sigma = \frac{F_{Sd}}{t L} \quad (12.5)$$

and F_{Sd} is applied force, t thickness of the connected element and L_w length of the weld.

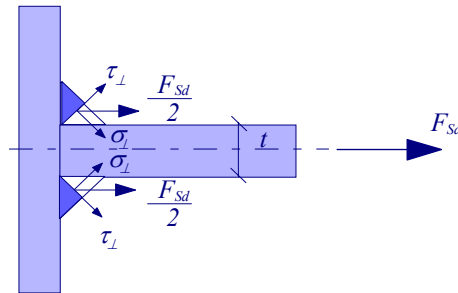

Figure 12.4 Double fillet welded joint loaded perpendicularly to the weld axis

Throat thickness of the weld loaded parallel to the axis, see Figure 12.5, should be bigger than

$$a > 0,85 \frac{t \tau \gamma_{Mw}}{f_w}, \quad (12.6)$$

where

$$\tau = \frac{F_{Sd}}{t L_w}. \quad (12.7)$$

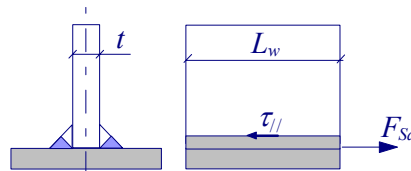

Figure 12.5 Double fillet welded joint loaded parallel to the weld axis

Q&A 12.3 Butt welds in aluminium joints

What information does Eurocode 9 provide with respect to the characteristics of partially penetrated butt welds between the aluminium elements?

When butt welds are used for connecting aluminium elements, full penetration butt welds should be used. Partial penetration butt welds should be used only in cases, when verified by testing that no serious weld defects are apparent. In other cases partial penetration butt welds shall be only applied with a higher partial safety factor γ_M because of the high susceptibility for weld defects.

The effective thickness of full penetration butt weld is taken as the thickness of the connected elements. When elements with different thickness are welded, the smaller shall be taken into account as weld thickness. For partial penetration butt welds an effective throat thickness should be applied, see Figure 12.6. The effective length should be taken as the total length of the weld when run-on and run-off plates are used. Otherwise the total length should be reduced by twice the thickness a .



Figure 12.6 Effective throat thickness of partial penetration butt weld

The stresses in butt welds should satisfy the following criteria:

The normal stress, tension or compression, perpendicular to the weld axis

$$\sigma_{\perp} \leq \frac{f_w}{\gamma_{Mw}}, \quad (12.8)$$

shear stress parallel to the weld axis

$$\tau \leq 0,6 \frac{f_w}{\gamma_{Mw}}, \quad (12.9)$$

and combination of normal and shear stresses

$$\sqrt{\sigma_{\perp}^2 + 3 \tau^2} \leq \frac{f_w}{\gamma_{Mw}}. \quad (12.10)$$

Table 12.2 Values of HAZ softening factor ρ_{haz}

Alloy series	Condition	ρ_{haz} (MIG welding)	ρ_{haz} (TIG welding)	Note
Extrusions, sheets, plates, drawn tubes and forgings				
Any	O F	1,00	1,00	
6xxx	T4	1,00	-	
	T5	0,65	0,60	
	T6	0,65	0,50	
7xxx	T6	0,80	0,60	applied when tensile stress acts transversely to the axis of butt or fillet
		1,00	0,80	applied for all other conditions
Sheets, plates, and forgings				
5xxx	H22	0,86	0,86	
	H24	0,80	0,80	
3xxx	H14 H16 H18	0,60	0,60	
1xxx	H14	0,60	0,60	

Q&A 12.4 Heat Affected Zones

How does the development of high temperatures in the vicinity adjacent to the welds affect the design of aluminium welded connections?

Structural aluminium is weakened in the heat affected zones (HAZs) adjacent to welds. The affected region extends immediately around the weld, beyond which the strength properties rapidly recover their full values. Eurocode 9 Clause 6.6.2 deals specifically with heat-affected zones (HAZ), which need to be taken into account for the following classes of alloys:

- Heat-treatable alloys in any heat-treated condition above T4 (6xxx and 7xxx series)
- Non-heat-treatable alloys in any work-hardened condition (3xxx and 5xxx series)

In alloys in O or T4-condition, or when material is in the F-condition and design strength is based on O-condition properties, there is no weakening in the vicinity of welds [Dwight, 1999]. Here the

severity and extent of HAZ are different for TIG and MIG welding. For TIG welding, a larger HAZ area and more severe softening due to higher heat-input is considered [Mazzolani, 1985].

The two main aspects of HAZ softening are its severity and its extent. The characteristic strengths f_o, f_a, f_v in the HAZ are calculated in a way determined in the Eurocode 9 for the parent metal and reducing them by softening factor ρ_{haz} . The other method is reducing the area over which the stress acts, see Figure 12.7. Thus the design resistance of a simple rectangular section affected by HAZ softening can be expressed as

$$F_{Rd} = \frac{A(f_a \rho_{haz})}{\gamma_{Mw}} = \frac{A f_{a,haz}}{\gamma_{Mw}}, \quad (12.11a)$$

or

$$F_{Rd} = \frac{(\rho_{haz} A) f_a}{\gamma_{Mw}}. \quad (12.11b)$$

The values of ρ_{haz} are provided in Table 12.2.

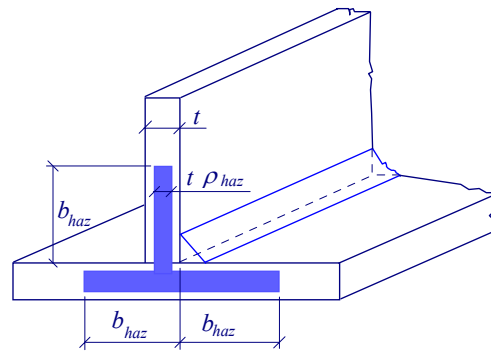

Figure 12.7 Heat affected zones at fillet weld

These values are valid from the following time after welding, providing the material has been held at a temperature not less than 10°C:

- 6xxx series alloys- 3 days,
- 7xxx series alloys- 30 days.

Table 12.3 Extent of HAZ for MIG and TIG welding

Thickness t	b_{haz} (MIG welding)	b_{haz} (TIG welding)
$0 < t \leq 6 \text{ mm}$	20 mm	30 mm
$6 < t \leq 12 \text{ mm}$	30 mm	-
$12 < t \leq 25 \text{ mm}$	35 mm	-
$t > 25 \text{ mm}$	40 mm	-

If the material is held at a temperature lower than 10°C after welding, the recovery time will be prolonged. Advice should be sought from the manufacturer. The heat affected zone is assumed to extend over a distance b_{haz} in any direction from the weld, see Figure 12.8 and Table 12.3. If the distance from the weld to the edge of the element is smaller than three times b_{haz} , then the HAZ extends to the full width of the element. The measurement of b_{haz} is taken as follows:

- transversely from the centre line of an in-line fillet weld,
- transversely from the point of intersection of the welded surfaces at fillet welds,
- transversely from the point of intersection of the welded surfaces at butt welds used in corner, tee or cruciform joints,
- in any radial direction from the end of the weld.

The HAZ boundaries should generally be taken as straight lines normal to the metal surface, particularly when welding thin materials. However, when surface welding is applied to thick material it is permissible to assume a curved boundary of radius b_{haz} .

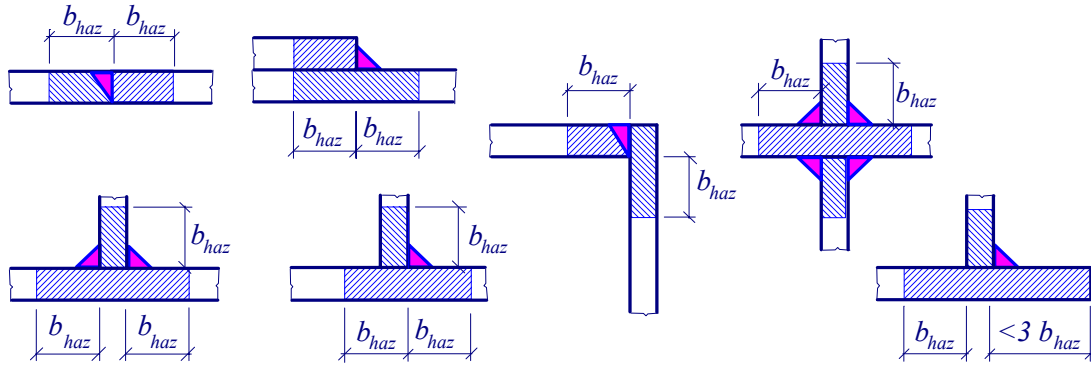

Figure 12.8 Heat affected zones at fillet weld

Characteristic strength of the heat affected zones is reduced to

$$f_{a,haz} = f_a \rho_{haz} \quad (12.12)$$

For the fully penetrated butt weld the strength in the heated affected zone is limited to

$$\sqrt{\sigma_{haz}^2 + 3 \tau_{haz}^2} \leq \frac{f_{a,haz}}{\gamma_{Mw}} \quad (12.13)$$

and for the partially penetrated butt weld, see Fig. 12.9, to

$$\sqrt{\sigma_{haz}^2 + 3 \tau_{haz}^2} \leq \frac{t_e}{t} \frac{f_{a,haz}}{\gamma_{Mw}} \quad (12.14)$$

For a fillet weld the strength in the heated affected zone at the toe of the weld is limited to

$$\sqrt{\sigma_{haz}^2 + 3 \tau_{haz}^2} \leq \frac{f_{a,haz}}{\gamma_{Mw}}, \quad (12.15)$$

respectively for fillet welds at the fusion boundary

$$\sqrt{\sigma_{haz}^2 + 3 \tau_{haz}^2} \leq \frac{g_l}{t} \frac{f_{a,haz}}{\gamma_{Mw}} \quad (12.16)$$

As a conclusion, it can be noted that the deformation capacity of a welded joint can be improved when the design strength of the welds is greater than that of the material in the HAZ.

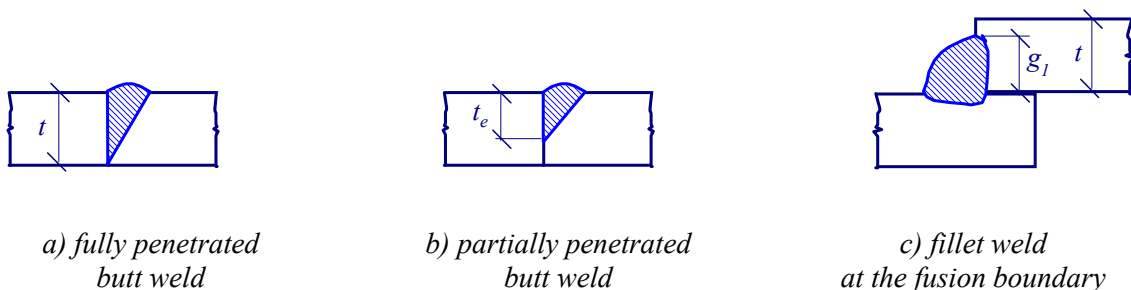

Figure 12.9 Penetration of welds

13 GOOD AND BAD DETAILING

Many different detailing solutions can be used to connect one steel member to another. Furthermore, the differences in custom and practise between European countries, differences in labour costs, production and erection methods and site conditions can lead to a bewildering number of different solutions. All too often bad detailing is used leading to unsightly connections, connections which clearly do not fulfil their design function and connections which may introduced unwanted secondary effects into the structure. Poor detailing can also give rise to fabrication and/or erection difficulties and increase the cost of the structure.

The main aspects, which need to be considered during the design and detailing of a connection are summarised in Table 13.1. Figures 13.1 to 13.2 also give examples of good and bad detailing and are based on real completed project within the European Community. Table 13.2 at the end of this chapter assess each detail and summarise the good and bad aspects of each solution.

Table 13.1 Aspects to be considered during connection design

Calculation	Transfer of forces by connection Eccentricities in connection Codes Design [EN 1993-1-1] Connection design [EN 1993-1-8] Erection [EN 1090-1]
Appearance	Architectural shape Corrosiveness of environment
Drawing	Possibility of standardization Restriction on number of different elements Restriction on number of bolt types/lengths/grade
Production	Fabricator's experience and practice Restriction on handling Cutting Drilling Notching Welding Repair of redundant deformations Protection system Paint Galvanize Transport (damage) Replacement of parts
Erection	Erection difficulties Tolerances Sections dimensions Production and precision Site fittings Number of bolts Type Grade Length Length of threaded part Washers Method of tightening of bolts

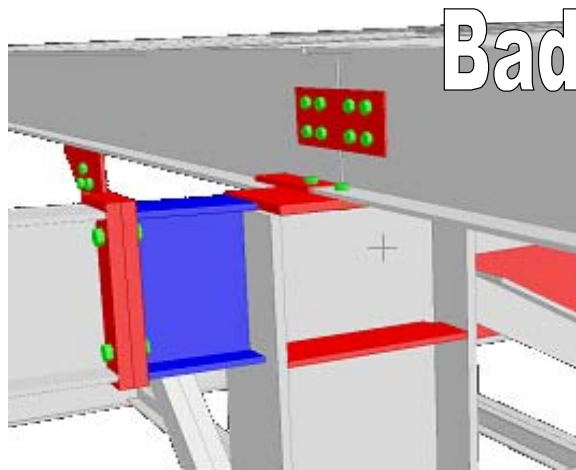

Figure 13.1 Beam to column joint, moment connection to major axis of column, simple connection to minor axis, unsuccessful solution because of instability during erection and expensive solution difficult to fabricate and erect; beams IPE 330; bolts 4xM20; moment connection: end plate resistance $M_{j,Rd} = 98,4 \text{ kNm}$; weld resistance $M_{j,Rd} = 297,3 \text{ kNm}$

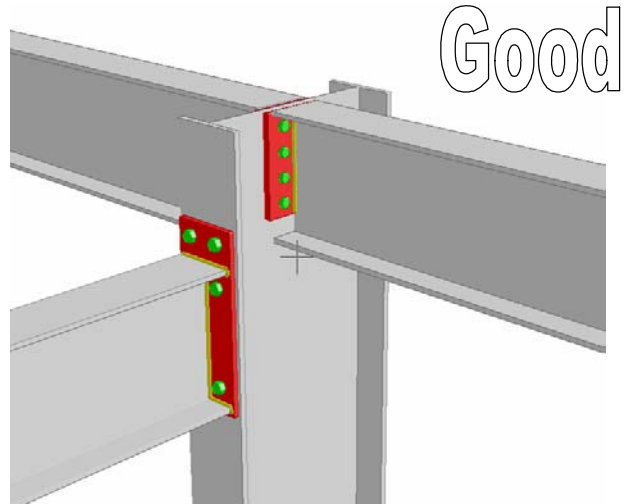

Figure 13.2 Beam to column joint, moment connection to major axis of column, simple connection to minor axis, successful case with extended end plate to major axis and header plate to minor axis; beams IPE 330; bolts 6xM20; moment connection resistance $M_{j,Rd} = 139,9 \text{ kNm}$

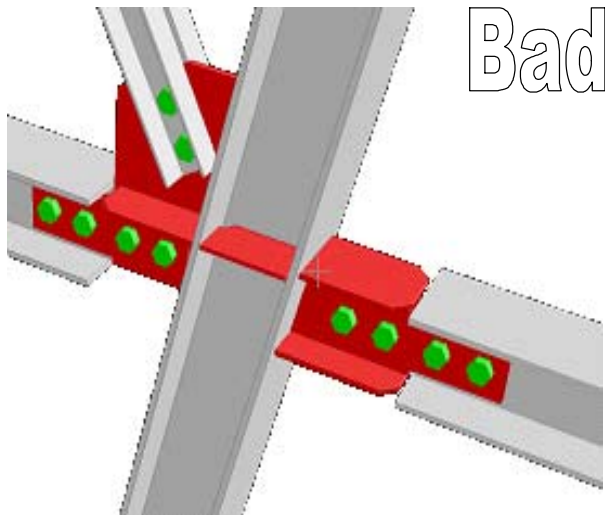

Figure 13.3 Simple beam to column joint of open hot rolled sections with diagonal bracing, unsuccessful case because of difficult to fabricate and erect, expensive solution; column HE180B; beam HE180B; bolts 4xM20

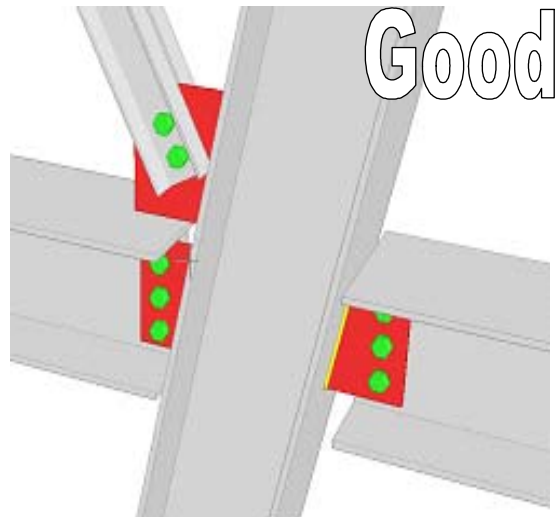

Figure 13.4 Simple beam to column joint of open hot rolled sections with diagonal bracing, successful case with fin plates, column HE180B; beam HE180B; bolts 3xM20

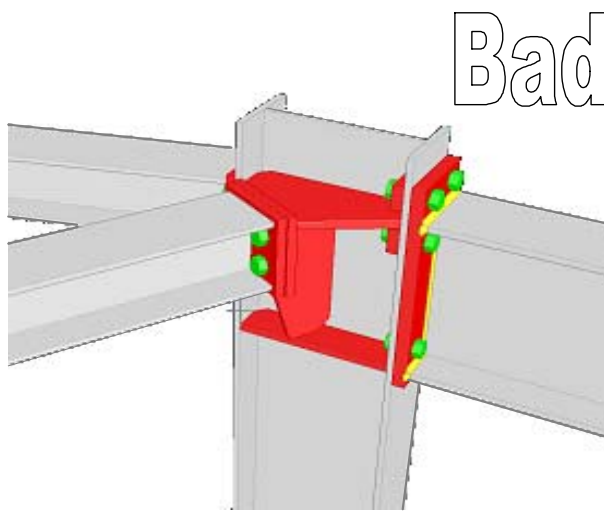

Figure 13.5 Beam to column joint with moment connection to major axis and simple connection to minor axis, unsuccessful case because of unclear transfer of forces, an expensive solution; secondary beams HE120A; moment connection: beam IPE270; bolts 6xM16

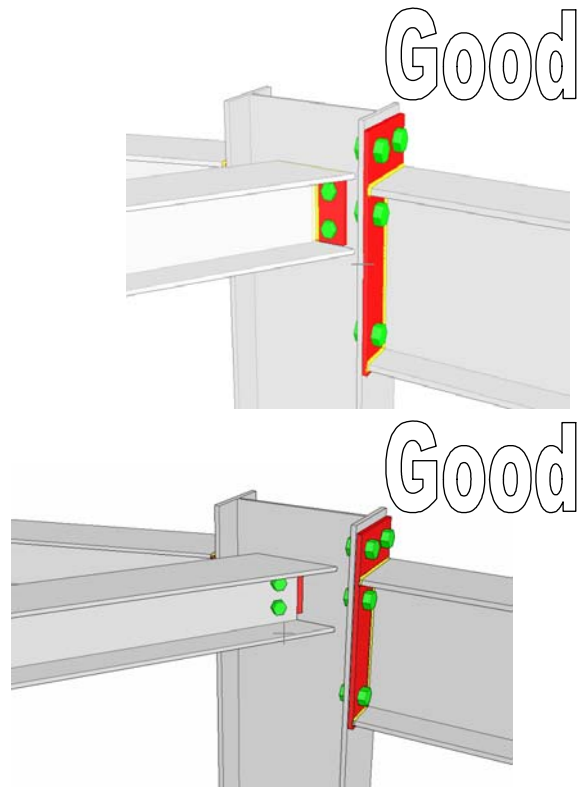

Figure 13.6 Beam to column joint with moment connection to major axis, simple connection to minor axis, successful case with extended end plate to major axis and header plate/ beam splices to minor axis; secondary beams HE120A; moment connection: beam IPE270; bolts 6xM16

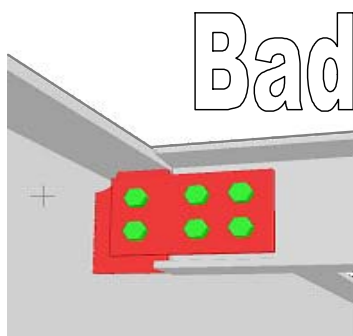

Figure 13.7 Beam to beam joint of open sections, simple connection in global analyses; unsuccessful case because of introduction of eccentricity, difficult to erect; beam HE 1000A, secondary beam IPE 240; bolts 6xM16

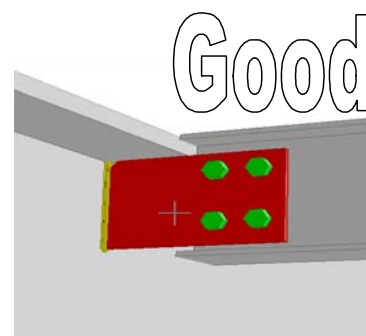

Figure 13.8 Beam to beam joint of open sections, simple connection in global analyses; successful case with long fin plate; beam HE 1000A, secondary beam IPE 240; bolts 4xM16

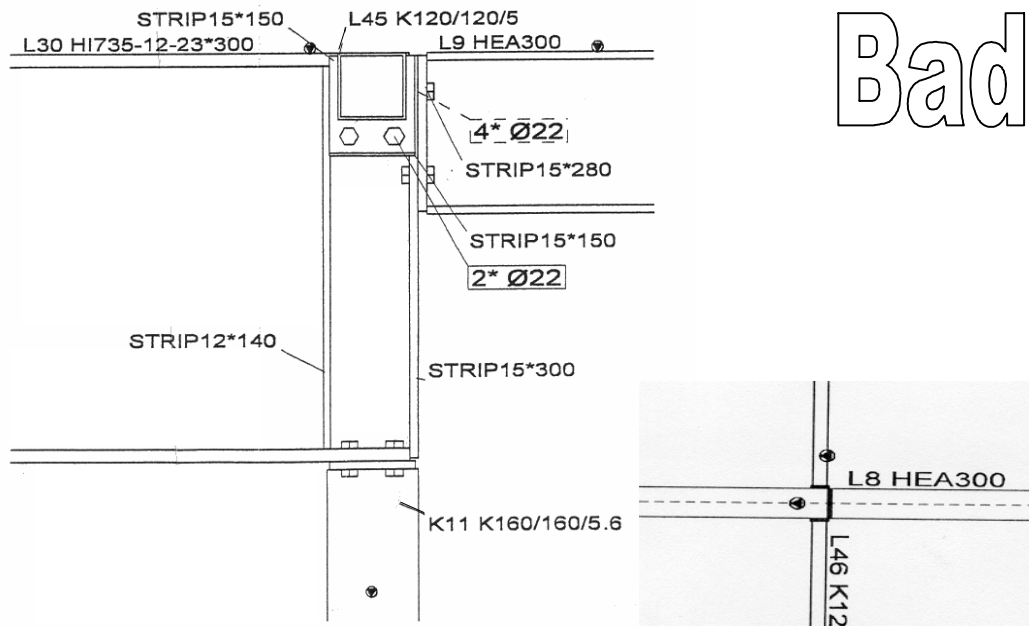

Figure 13.9 Simple beam to column joint, beams of open cross sections, column RHS tube; unsuccessful case - danger of instability during erection and an expensive solution

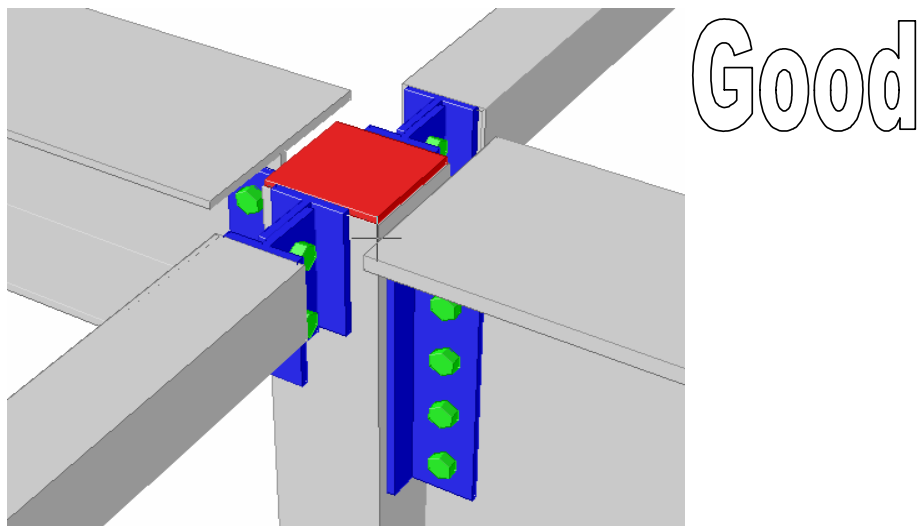
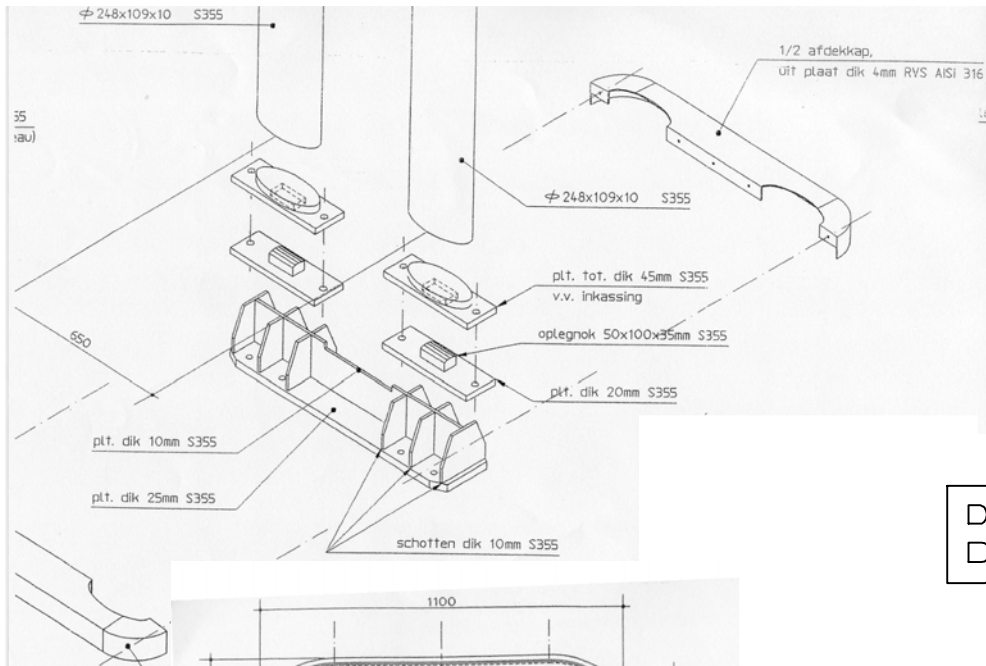

Figure 13.10 Simple beam to column joint, successful case by web angles



Bad

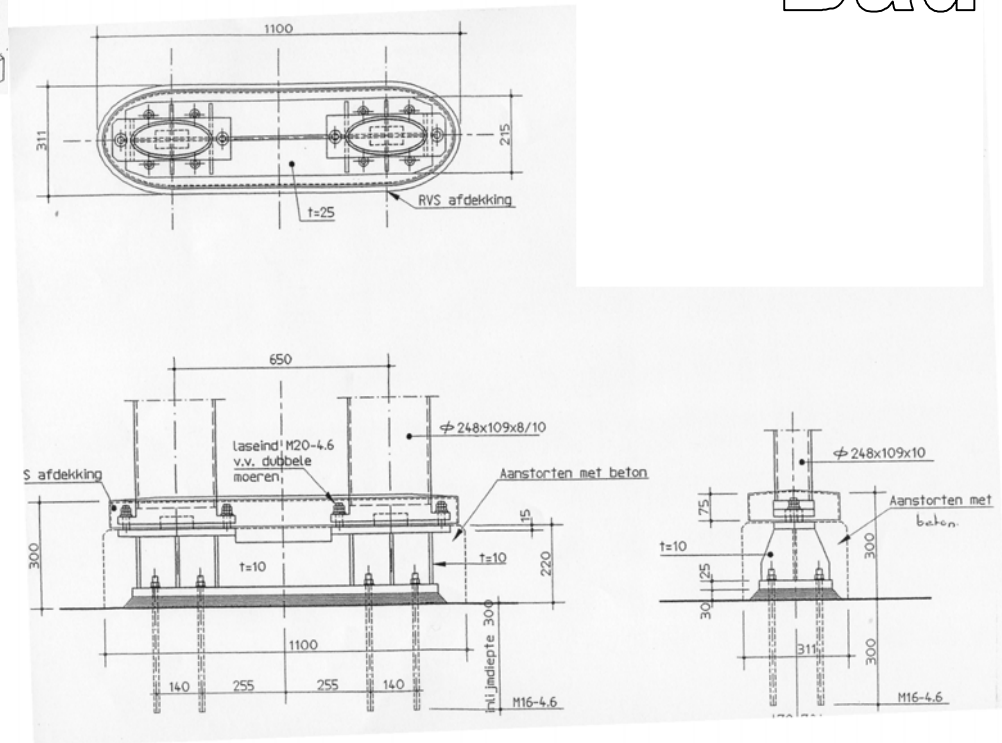
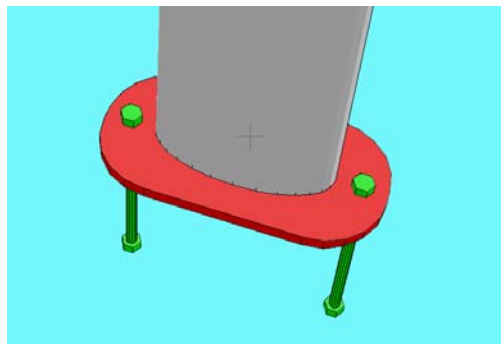
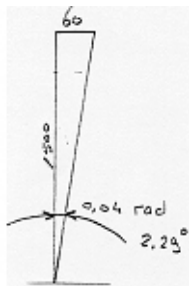

Figure 13.11 Base plate, in global analyses represented in direction of major axis of column as rigid and in minor axis as simple; unsuccessful case because of very high complexity/price



Good

Figure 13.12 Base plate, successful case with simple base plate, in global analyses the stiffness can be introduced

Table 13.2 Assessment of good and bad detailing examples in Fig. 13.1 - 13.12

Example		Fig. 13.1-2	Fig. 13.3-4	Fig. 13.5-6	Fig. 13.7-8	Fig. 13.9-10	Fig. 13.11-12
Observed parameter		Column + 2 continuous top beams	Column + 2 girders	Column + 2 girders + 1 sleeper	Main girder + 1 sleeper	Column + 4 girders	Column foot with rotating possibility
		moment connection	pin connection	moment connection	pin connection	pin connection	pin connection
Design	B	00	000	0	0	000	00
	G	++	+++	++	++	+++	++
Drawings	B	00	000	00	0	00	000
	G	++	++	++	++	++	+++
Plates	B	8	7	9	3	8	20
	G	3	3	3	1	-	1
Profiles	B	-	2	-	-	-	2
	G	-	0	-	-	8	0
Measurement	B	00	000	00	+	00	00
	G	+	+++	++	+	+++	++
Holes	B	0	00	+	0		00
	G	++	++	+	+	00	+++
Welding	B	0	00	00	+	+	000
	G	++	++	+	+	12	++
Bolts	B	16	10	14	6	12	12
	G	14	8	12	4	00	2
Architecture	B	0	00	00	0	++	0
	G	+	++	+	+	000	++
Corrosion	B	00	0	00	0	++	000
	G	++	+	++	+	0	++
Transport	B	0	0	0	++	+	00
	G	+	+	+	0	+	++
Building Tolerances	B	0	++	00	++	00	000
	G	+	+0	+	+	++	++
Erection	B	+	0	0	0	0	000
	G	+	+	+	+	++	++

Note:

Bad cases	B
Number	Quantity required
000	very bad
00	bad
0	not good/doubtful

Good cases	G
Number	Quantity required
+	better
++	good
+++	very good

Program Non-linear Analysis by Component Method

The NASCon (Non-linear Analysis of Steel Connections) program was built using Borland Delphi 6 (Object Pascal) development tool, main menu is shown on Figure 14.1. It offers a computer user-friendly tool for the component method which allows modelling the nonlinear behaviour of different components; see [Costa Borges, 2003]. The file NASCon/intro opens the program menu. Project manual (file NASCon_manual.pdf) explains program features.

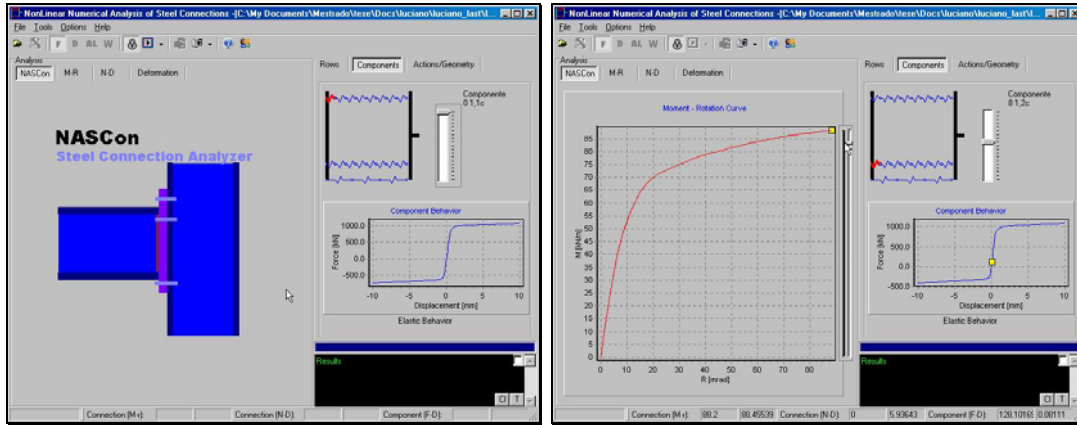

a) menu of program b) component behaviour
 Figure 14.1 Program nonlinear analysis of steel connections NASCon

Video - Statically Stressed Bolts in Dynamically Loaded Connections

The video film to Q&A 6.8 demonstrates the correct design of T-stub connections and bolted splices to avoid a fatigue failure of bolts, see Figure 14.2. The file name is Bolts_ISDN.mpg.

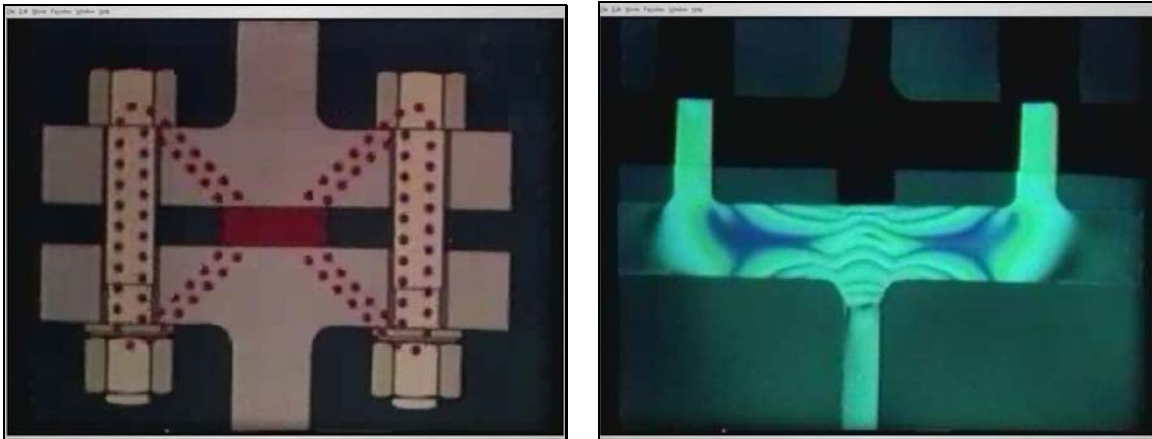

Figure 14.2 The flow of the stresses in the connection in video film Statically Stressed Bolts in Dynamically Loaded Connections

15 Text of PowerPoint Lesson

The Chapter 9 - Fire design is equipped by the PowerPoint lessons including video/audio sequences, see Figure 15.1. The lessons in are available on a Project CD or can be downloaded at Project Internet page www.fsv.cvut.cz/cestruco.



Figure 15.1 a) Front page of PowerPoint lesson "Connection Design for Fire Safety",
b) a slide from the lesson "Heating and cooling of structure"

Recommended configuration

Recommended configuration for Internet/CD videos is PENTIUM 1,4 GHz, Microsoft Windows 2000 / XP, sound card, 24×CD-ROM. Video player capable to play the sequences in the MPEG1 format. For a proper presentation of the PowerPoint lessons with video clips it is necessary to install the following software: Microsoft PowerPoint 2002 (10.4205.4219) SP-2. The older versions do not reproduce video sequences properly.

Text of lesson

Connection Design for Fire Safety - Cardington Structural Integrity Fire Test

- [1] Fire safety of structures may be increased by structural design for the exceptional loading condition created by fire. The level of safety which can be achieved has been shown by a fire test on a real structure at Cardington, which was conducted in order to improve knowledge about structural integrity in fire.
- [2] This lesson introduces connection design for fire safety: distribution of temperature, thermal properties, and component method. The preparation, execution and major results of the structural integrity test in the Cardington laboratory are shown. At the end is the connection design summarised.
- [3] The modelling of the structure involves three stages. The first stage is to model the fire scenario to determine the heat energy released from the fire and the resulting atmospheric temperatures within the building. The second stage is to model the heat transfer between the atmosphere and the structure. The third stage is to determine the response of the structure. The definition of fire resistance is the ability of a building or its elements to satisfy for a stated period of time agreed criteria of load bearing capacity, integrity and insulation. The design of connections for fire safety involves calculation of the heat transfer to them and a determination of the response of the structural elements of the connections.
- [4] The design for high temperatures takes into account both the degradation of material properties and elongation of the heated elements, as well as the contraction of elements in cooling. In the connections, because of the presence of concentrations of material, the temperature variation lags behind the corresponding temperature variation for the connected steel members.
- [5] The basis of connection design in fire is the temperature distribution in its elements.

- [6] The fire safety part of the European standard for the design of steel structures includes an Annex which gives rules to evaluate the behaviour of welds and bolts at high temperatures.
- [7] In line with the cold design of steel joints, the component method is applicable to the design of connections at high temperatures. The first step is to divide the connection into its components.
- [8] The resistance of each component is reduced at high temperature and this is expressed by a strength reduction factor. The deformation of the component is controlled by a reduction of its modulus of elasticity.
- [9] The connection behaviour may be described on the basis of its component behaviour and temperature distribution.
- [10] An example of change in the behaviour of an end-plate connection with temperature.
- [11] The large-scale building test laboratory is housed in a former airship hangar at Cardington
- [12] The laboratory has a uniquely large space of 48 m x 65 m x 250 in which to conduct experiments.
- [13] Three multi-storey buildings were built at full scale. In front is situated the six-floor timber-framed building. The figures on the right shows a fire test of timber stairs and the test of structural integrity by impact of vehicle.
- [14] In the centre of laboratory are located the seven-floor concrete framed building. The photos on the right are showing fire load by timber ribs in the fire compartment and the column as well as concrete slab after fire test.
- [15] The composite steel and concrete building was finished in 1994.
- [16] The structure is made of open sections and simple connections. The composite slab was cast onto corrugated metal decking.
- [17] Seven large fire tests have been performed on different levels of the composite frame.
- [18] The major objective of tests No. 1 and No. 2 was to study element performance in a real structure. Natural gas was used for heating in these tests.
- [19] Tests No 3 to No 6 were designed to study composite slab behaviour in fire. Timber cribs were burned to simulate the fire load in the office building.
- [20] For a composite multi-storey building it is desirable to fire-protect the compression members and to leave unprotected members in bending. The importance of protection of members in compression was demonstrated in the second test, where a part of the column was not protected.
- [21] Test No 7 was designed to study the structural integrity of the structure in the wake of the collapse of the World Trade Centre towers on September 11 2001. The work is part of project CV 5535 of the European Union Fifth Framework programme. The objectives of the test were to study temperatures in elements and joints, the internal forces in the connections, and the behaviour of the composite slab.
- [22] The fire compartment was built on the third floor. The walls were constructed of three layers of gypsum plasterboard attached to thin-walled profiles. The window opening was designed to allow good but controlled ventilation during the fire.
- [23] The columns were fire insulated by 15 mm of Cafco300 vermiculite-cement spray. External joints were protected together with 1 m of the attached primary beams. The compartment was instrumented with 148 thermocouples, 57 regular-temperature strain gauges and 10 high-temperature strain gauges.
- [25] 27 vertical and 10 horizontal deformations were measured.
- [26] Ten video cameras and two thermal imaging cameras recorded the fire and smoke development, the deformations and temperature development.
- [27] Sand bags represent the mechanical loadings; 100% of permanent actions, 100% of variable permanent actions and 56% of live actions.
- [28] Cribs of 50 x 50 mm timber produced a fire load of 40 kg/m².
- [29] The fire test was performed on January 16, 2003, after four months of preparation under the supervision of the Bedford Fire Department. The burning was smooth from ignition, developing towards flashover and finally cooling. The smoke development was limited by the design of the openings. The time is shown on the graph of the gas temperature development. We may see the bending of the primary beam during the fire through the window of the compartment.
- [30] The slab reached 1220 mm maximum deflection during heating, which recovered to 925 mm of residual deflection on cooling. The time is shown on the graph of the gas temperature development. The deflection is shown from readings on secondary beam in the centre of the compartment.
- [31] The cracks in the plate opened in 53 minute of the test.

- [32] The thermal imaging cameras give a visual representation of the temperature of the structure by colours over areas of about 24 to 24 millimetres. The fin plate connection of the secondary beam to the primary beam was observed. Local buckling of the lower flanges of beams is visible after 23 min of heating. The animation of thermographs shows the delay in the heating and cooling of the connections.
- [33] The development of the temperature in the compartment was predicted accurately. The graph shows the prediction of the gas temperature and the measured gas temperature. The highest temperature was reached at the back of the compartment. The maximum predicted temperature was 1078 °C at 53 min., whereas the actual maximum was 1108°C at 55 min.
- [34] The lower flange of the secondary beam achieved the highest temperature of any part of the structure. Its predicted maximum temperature was 1067 °C at 54 min, compared with the actual maximum of 1088 °C at 57 min.
- [35] The thermocouple measurements compare the temperatures in the components of the fin plate connection to the temperature of the lower flange of the connected secondary beam.
- [36] The beam to column header plate connection reached about 250°C less than the lower flange of the connected secondary beam.
- [37] After the fire only ashes remained from the timber ribs in the compartment.
- [38] Due to compression the beam webs buckle locally at elevated temperatures. The local buckling is located in zones of negative bending close to connections or colder parts of the beam.
- [39] The bearing of the fin plate on the beam web allows ductile deformation of the fin plate connection.
- [40] The header plate fractures in the heated affected zone of its weld on one side of the connection during the cooling phase. The connection continues to transfer the shear forces through the remaining part.
- [41] Connections are loaded in compression during heating and in tension during cooling. Reduction of the stresses due to local buckling may be observed.
- [42] The column flange exhibits some local buckling.
- [43] Shear buckling takes place in the beam web.
- [44] We may conclude based on the test
that collapse of structure was not reached for the fire load of 40 kg/m^2 , which well represents the fire load in a typical office building, together with a mechanical load greater than standard approved cases.
The structure showed good structural integrity.
The test results supported the concept of unprotected beams and protected columns as a viable system for composite floors.
- [45] Local buckling of the lower flanges of beams was observed after 23 min of heating. The fracture of end plates occurred under cooling in the heated affected zones of welds without losing the shear capacity of the connections. The well-designed fin plate connections behaved in ductile fashion due to elongation of holes in bearing.
- [46] The connections were exposed to different forces compared to those at room temperature because of their exceptional loading by fire. The good design of connections leads to robust behaviour.
Connections in a structure are relatively cool compared to their connected elements due to their concentration of mass . There is no need for special checking and no need for local thermal insulation of normal connections. If there are beam splices within a beam span exposed to fire a component method gives a good prediction of the behaviour.
- [47]
- [48] The experiment was carried out with the support of the EU Fifth Framework project No. CV 5535 “Tensile membrane action and robustness of structural steel joints under natural fire”.
- [49] The authors would like to thank to all members of the European project team who worked at the Cardington laboratory on the test.
- [50] The Czech Technical University in Prague has produced this lesson as part of the project “Continuing Education in Structural Connections” which was supported by the European Community under the Leonardo da Vinci Programme.

List of symbols

a	throat thickness of fillet weld
a_l	effective length of the foundation, length of the base plate
a_c	height of the column cross-section
a_h	size of the anchor head
b	width of angle leg, width of the base plate
b_0, b_l, b_w	width, effective width of the foundation
b_b	width of beam flange
b_c	width of the column cross-section, of column flange
b_{eff}	effective width
b_{haz}	width of heat affected zone
b_p	width of end plate
c	effective width of the flexible base plate
c_{\emptyset}	required concrete cover for reinforcement
d	nominal diameter of the bolt
d_0	diameter of the bolt hole
d_0, d_1, d_2	diameter
d_h	diameter of anchor head
e	eccentricity, distance from bolt to edge of T-stub, from edge of the angle
e, e_x, e_a, e_b	bolt distances
e_0	eccentricity of the joint
e_1, e_2	bolt end distance, in force direction, perpendicular to force direction
e_x	distance from bolt to edge of end plate
f_a	characteristic strength for local capacity in tension and compression
$f_{a,haz}$	characteristic strength of heat affected zone
f_{cd}	design value of compressive cylinder strength of concrete $f_{cd} = f_{ck} / \gamma_c$
$f_{cd,g}$	design value of compressive cylinder strength of grout
f_{ck}	characteristic value of concrete compressive cylinder strength
f_j	concrete bearing strength
f_o	characteristic strength for bending and yielding in tension and compression
f_u	ultimate strength
f_{ub}	ultimate strength of the bolt
f_v	characteristic shear strength
$f_{v,haz}$	characteristic shear strength of heat affected zone
$f_{vw,d}$	design shear resistance of the fillet weld per unit length
f_w	characteristic strength of the weld metal
f_y	yield stress of steel
f_{ya}	average yield strength
f_{yb}	yield stress of the bolt
f_{yc}	yield stress of column
g	length of the gap
g_l	leg length of fillet weld
h, h_0, h_l	height, height of concrete foundation
h_c	height of column cross section
h_{ef}	length of anchor embedded in the concrete
k	stiffness coefficient
k_c	total stiffness coefficient of the compression zone
k_{eff}	total stiffness coefficient of one bolt row in tension
k_{eq}	total stiffness coefficient the tension zone
k_i	stiffness of component i
k_j	stress concentration factor
k_{θ}	reduction factor based on material temperature

m, m_x	distance from the bolt centre to the plate
m_1, m_2	distances from bolt to web of T-stub
$m_{pl,Rd}$	plastic bending moment resistance of the base plate per unit length
m_x	distance from bolt to beam flange
n	distance from bolt centre to contact with the foundation
p	bolt pitch
p_1, p_2	bolt pitch; in force direction, perpendicular to force direction
r	lever arm
r_c	fillet radius of column
r_e	theoretical resistance obtained from the design model
r_t	experimentally found resistance
t	thickness
t_0, t_1, t_2, t_w	thickness
t_e	effective thickness of partial penetration butt weld
t_f	thickness of flange
t_{fb}	thickness of beam flange
t_{fc}	thickness of column flange
t_g	thickness of grout
t_h	thickness of anchor head
t_p	thickness of plate thickness, of end plate
t_{tc}	thickness of column flange
t_w	thickness of the column web
t_{wa}	thickness of the washer
t_{wc}	thickness of column web
w_1, w_2	distance between bolts
x, y, z	axes
z	lever arm
z_c	lever arm of compression zone
$z_{c,b}$	lever arm of compression zone at bottom of the joint
$z_{c,t}$	lever arm of compression zone at top of the joint
z_{eq}	equivalent lever arm
z_t	lever arm of tension zone
A	area, surface area of the member per unit length
A_0	area
A_b	total area of bolt, unthreaded part
A_c	area of the column
A_{eff}	effective area; of the flexible base plate, of the cross-section
A_g	area of the gross section
A_h	bearing area of the bolt head
A_{net}	net area
A_s	net area of the bolt, in thread
A_v	shear area
B_e	effective length
$B_{t,Rd}$	design resistance of bolt in tension
C_0, C_1	constant values
C_e, C_T, C_X, C_K	efficiency parameter
$C_{f,d}$	friction coefficient

E	Young's modulus of steel
F	force
$F_{b,Rd}$	design bearing resistance
$F_{c,b,Rd}$	design resistance in compression in bottom zone of the joint
$F_{c,fb,Rd}$	design resistance of beam flange in compression
$F_{c,Rd}$	design resistance in compression
$F_{c,t,Rd}$	design resistance in compression in top zone of the joint
$F_{c,wc,Rd}$	design resistance of column web in compression
F_{el}	elastic limit
$F_{exp,fy/fum}$	resistance for the structural members obtained from the tests to failure
$F_{o,Rd}$	pull-out resistance
$F_{p,Cd}$	design preloading force
$F_{p,Rd}$	pull-through resistance
F_{Rd}	design resistance
F_{Sd}	applied force
$F_{t,Rd}$	design tension resistance
$F_{t,Sd}$	tensile force
$F_{t,ep,Rd}$	design resistance of end plate in bending
$F_{t,fc,Rd}$	design resistance of column flange in bending
$F_{t,wb,Rd}$	design resistance of beam web in tension
$F_{t,wc,Rd}$	design resistance of column web in tension
$F_{t,i,Rd}$	resistance of the i -th bolt row in tension
$F_{v,max}$	maximum shear force obtained in a test
$F_{v,Rd}$	design shear resistance
$F_{v,Sd}$	shear force
$F_{w,Rd}$	resistance of the weld per unit length
HAZ	Heat Affected Zone
I	second moment of inertia
I_b	second moment of inertia of beam
I_c	second moment of inertia of column
$\bar{S}_{j,ini}$	relative initial stiffness
$K_{i,e,20^\circ C}, K_{i,pl,20^\circ C}$	elastic and plastic stiffness of the component, at ambient temperature
L, L_l	length, beam span
L_b	length of beam
L_b	free length of the anchor bolt
$L_{b,lim}$	maximal bolt length, when anchor bolt may be exposed to prying
L_{be}	embedded length of the anchor bolt
L_{bf}	length of anchor bolt above the concrete foundation
L_c	length of column
L_{eff}	effective length of a T-stub
L_{eq}	equivalent length of the anchor bolt
L_w	length of fillet weld

$L_{w,eff}$	effective length of fillet weld
M	bending moment
M'	bending moment per unit length
$M_{j,Rd}$	moment resistance of joint
$M_{j,ult,d}$	predicted ultimate bending moment of joint
$M_{j,ult,exp}$	experimental ultimate bending moment resistance of joint
$M_{pl,Rd}$	plastic bending moment resistance of member
M_{Sd}	applied bending moment
M_w	bending moment carried by the weld
N	normal force
N_0, N_1, N_2	axial force
N_{Iy}	axial force of the chord corresponding to the plastification
$N_{pl,Rd}$	resistance of cross section
N_{Sd}	applied axial force
$N_{u,Rd}$	design ultimate resistance of the cross-section
Q	prying force
R_d	resistance of the connection
R_{fy}	plastic resistance of the connected dissipative member
S_j	stiffness of joint
$S_{j,sec}$	joint secant stiffness
$S_{j,ini}$	initial stiffness of joint
$S_{j,ini}$	initial stiffness of the joint
V	volume of the member per unit length
$V_{G,Ed}$	shear force due to the non seismic actions
$V_{M,Ed}$	shear force due to the resisting moments at the end sections of the beam
$V_{pl,Rd}$	plastic resistance to the shear force
V_{Sd}	design shear effort
$V_{wp,Rd}$	design resistance of column web panel in shear
W_{ext}	external energy
W_{int}	internal energy
α	reduction factor of bearing resistance
α_b	factor for bearing resistance
α_d	factor of end distance and pitch for bearing resistance
β	transformation parameter for shear loading
β, β_2, β_3	reduction factors
β_j	joint coefficient
β_{Lw}	reduction factor for long welds
β_w	correlation factor
δ	deformation, beam deflection at midspan, component deformation
δ_c	deformation of components in compression zone
$\delta_{b,c}$	deformation of components in compression zone at bottom of the joint

$\delta_{i,c}$	deformation of components in compression zone at top of the joint
δ_{Cd}	deformation capacity
δ_i	deformation of components in tension zone
$\Delta\theta$	temperature interval
Δt	time interval
ε	strain
ϕ	joint rotation
ϕ_{pl}	plastic rotation capacity
ϕ_p	available plastic rotation
γ	*partial safety factor
γ_M	*partial safety factor for the resistance
$\gamma_{M,fi}$	*partial safety factor for fire
γ_{M0}	*partial safety factor for steel
γ_{Mb}	*partial safety factor of bolted connections
γ_{Mw}	*partial safety factor for weld
γ_{Ms}	*partial safety factor of slip resistance
$\gamma_{Ms,ser}$	*partial safety factor of slip resistance at serviceability
γ_{M2}	*partial safety factor of net section at bolt holes
θ	temperature
θ_0	temperature of the lower beam flange at mid span
$\theta_1, \theta_2, \theta_i$	angle between diagonal and the chord
σ	normal stress
$\sigma_{//}$	normal stress parallel to the axis of the weld
σ_{\perp}	normal stress perpendicular to the axis of the weld
τ	shear stress
$\tau_{//}$	shear stress (in the critical plane of the throat) parallel to the weld axis
τ_{\perp}	shear stress (in the critical plane of the weld) perpendicular to the weld axis
η	stiffness modification coefficient
λ_1, λ_2	dimensions of the T-stub
$\bar{\lambda}$	relative slenderness
μ_0	degree of utilization
μ	stiffness ratio
ρ_{haz}	heat affected zone (HAZ) softening factor
ψ	shape factor

* in prEN 1993-1-8: 2003 are the partial safety factors for prediction of the resistance simplified:

γ_{M0}	partial safety factor of steel
γ_{M1}	partial safety factor of stability
γ_{M2}	partial safety factor of connectors (bolts, rivets, pins, welds, weld, plates in bearing)
γ_{M3}	partial safety factor of hybrid connections, or under fatigue loading
γ_{M4}	partial safety factor of an injection bolt
γ_{M5}	partial safety factor of joints in hollow section lattice girder
$\gamma_{M6,ser}$	partial safety factor of pins at serviceability limit state
γ_{M7}	partial safety factor of high strength bolts

Indexes

<i>20°C</i>	ambient temperature
<i>a</i>	structural steel
<i>b</i>	bearing; bolt
<i>c</i>	calculation
<i>cr</i>	critical
<i>d</i>	design value
<i>e</i>	elastic
<i>E</i>	Young's modulus
<i>f</i>	failure, furnace
<i>fi</i>	fire design
HAZ	Heat Affected Zone
<i>i</i>	component
<i>j</i>	joint
<i>m</i>	member
<i>max</i>	maximum
<i>min</i>	minimum
<i>pl</i>	plastic
<i>Rd</i>	design resistance
<i>Sd</i>	design loading
<i>t</i>	time, duration on fire exposure
<i>ten, t</i>	tension
<i>v</i>	shear
<i>w</i>	weld
<i>y</i>	yield

References

- [Aalberg, Larsen, 2000] Aalberg A., Larsen P.K.: Strength and Ductility of Bolted Connections in Normal and High Strength Steels, in Structural failure and Plasticity, ed. Zhao, Grzebieta, Pergamon, in 7th International Symposium on Structural Failure and Plasticity (IMPLAST), Melbourne, 2000.
- [Al-Jabri et al, 1998] Al-Jabri K.S., Lennon T., Burgess I.W., Plank R.J.: Behaviour of steel and composite beam-column connections in fire, Journal Constructional Steel Research, Vol. 46, pp. 1-3, 1998.
- [Al-Jabri et al, 1997] Al-Jabri K.S., Burgess I.W., Plank R.J.: Behaviour of steel and composite beam-to-column connections in fire, Vol. 1. Research Report DCSE/97/F/7, Department of Civil and Structural Engineering, University of Sheffield, 1997.
- [Anderson, 1998] Anderson D.: Composite steel - concrete joints in braced frames for buildings, COST C1, EU, Brussels 1998, ISBN 92-827-9573-X.
- [APK, 1996] Bourrier P., Brozzetti J.: Construction metallique et mixte acier-beton, Tome 2, Conception et mise en oeuvre, Editions Eyrolles, APK et ACIER, Paris, 1996.
- [Balio, Mazzolani, 1999] Balio G., Mazzolani F.M.: Design of Steel Structures, E&FN Spon, London, 1999, ISBN 0-412-23660-5.
- [Ballio, Mazzolani, 1983] Ballio G., Mazzolani F.M.: Theory and Design of Steel Structures, Chapman and Hall, London, 1983.
- [Ballerini et al, 1996] Ballerini M. a kol.: Shear capacity of blind bolted connections for RHS steel structural elements. Tubular Structures VII, ed.: Farkas, Jarmai, pp. 99-106, Balkema, Rotterdam, 1996.
- [Barnett et al, 2001] Barnett T.C., Tizani W., Nethercot D.A.: The practice of blind bolting connections to structural hollow sections: A review, Steel and Composite Structures, Vol. 1, No. 1, pp. 1-16, 2001.
- [BCSA 1996] BCSA, Joints in Simple Construction, SCSI, 2nd edition, London 1993, ISBN 1-870004-58-2.
- [Bickford, 1995] Bickford J.H.: An introduction to the design and behaviour of bolted joints, Third edition, Marcel Decker inc., New York 1995, ISBN 0-8247 9297-1.
- [Bijlaard, 1982] Bijlaard F.S.K.: Rekenregels voor het ontwerpen van kolomvoetplaten en experimentele verificatie, Rapport No. BI-81-51/63.4.3410, IBBC-TNO, Delft 1982.
- [Bijlaard et al, 1989] Bijlaard F.S.K., Sedlacek G., Stark J.W.B.: Statistical evaluations of the results of bolted connections, Background documentation, D.02, Delft, 1989.
- [Bijlaard et al, 1988] Bijlaard F.S.K., Sedlacek G., Stark J.W.B.: Procedure for the determination of design resistance from tests, Background report to Eurocode 3, BI-87-112, Delft, 1988.
- [Bouwman et al, 1989] Bouwman, L.P., Gresnigt A.M., Romeijn, A.: Onderzoek naar de bevestiging van stalen voetplaten aan funderingen van beton. (Research into the connection of steel base plates to concrete foundations), in Dutch, Stevin Laboratory report 25.6.89.05/c6, Delft, 1989.
- [BS 5950] BS 5950: Structural use of steelwork in buildings, BSI, London 1985.
- [Bulson, 1992] Bulson P.S.: Aluminium Structural Analysis: Recent European Advances, Elsevier, London, 1992, ISBN 1-85166-660-5.
- [Carril et al, 1994] Carril J.L., LaBoube R.A., Yu W.W.: Tensile and Bearing Capacities of Bolted Connections, Research Project, Department of Civil Engineering, Center for Cold-Formed Steel Structures, University of Missouri-Rolla, 2000.
- [CEB, 1997] Design of Fastenings in Concrete, Design guide, pp. 83, CEB, Thomas Telford Services Ltd., London, 1997, ISBN 0 7277 2558 0.
- [CEB, 1994] Fastenings to Concrete and Masonry Structures, State of the Art Report, pp. 248, CEB, Thomas Telford Services Ltd., London, 1994, ISBN 0 7277 1937 8.
- [CIDECT, 1991] Wardenier J., Kurobane Y., Parker J.A. Dutta D., Yeomans N.: Design guide for circular hollow section (CHS) joints under predominantly static loading, CIDECT, Construction with hollow steel sections, Verlag TUV Rheinland GmbH, Köln, 1991.
- [CIDECT, 1995] Wardenier J., Dutta D., Yeomans N. Parker J.A., Bucak O.: Design Guide for Structural Hollow Sections in Mechanical Applications, CIDECT, Construction with hollow steel sections, Verlag TUV Rheinland GmbH, Köln, 1995.

- [Costa Borges, 2003] Costa Borges L. A.: Probabilistic Evaluation of the Rotation Capacity of Steel Joints Dissertação apresentada à Faculdade de Ciências e Tecnologia para obtenção do grau de Mestre em Engenharia Civil, especialidade de Estruturas, Coimbra, 2003.
- [Davies, 1991] Davies J.M.: Connections for Cold Formed Steelwork, in Design of Cold Formed Steel Members, ed. Rhodes J., pp. 265-291, Elsevier Applied Science, 1991.
- [Davies, 1986] Davies J.M.: The Analysis of Sandwich Panels with Profiled Faces, In: Eight International Specialty Conference on Cold-Formed Steel Structures, St. Louis, Missouri, November 11-12, 1986.
- [De Matteis, Landolfo, 1999] De Matteis G., Landolfo R.: Mechanical fasteners for cladding sandwich panels: Interpretative models for shear behaviour, Thin-Walled Structures Vol. 35, pp. 61-79, Elsevier Science Publishers Ltd., 1999.
- [DeWolf, 1978] DeWolf J.T.: Axially Loaded Column Base Plates, Journal of the Structural Division ASCE, Vol. 104, No. ST4, pp. 781-794, 1978.
- [DeWolf, Ricker, 1990] DeWolf J.T., Ricker D.T.: Column Base Plates, Steel Design Guide, Series 1, AISC, Chicago, 1990.
- [DeWolf, Sarisley, 1980] DeWolf J.T., Sarisley E.F.: Column Base Plates with Axial Loads and Moments, Journal of the Structural Division ASCE, pp. 2167-2185, Vol. 106, No. ST11, 1980.
- [Dubina et al, 2000] Dubina D., Ciutina A.L., Stratan A.: Cyclic Tests on Bolted Steel and Composite Double-Sided Beam-to-Column Joints, The Paramount Role of Joints into the Reliable Response of Structures, pp. 129-139, NATO Science Series, ed. Baniotopoulos C.C., Wald, F., Series II, Vol. 4, Kluwer Academic Publishers, Dordrecht, 2000, ISBN 0-7923-6700-6.
- [Dubina, Stratan, 2002] Dubina D., Stratan A.: Behaviour of Welded Connections of Moment Resisting Beam - to - Column Joints, Engineering Structures - The Journal of earthquake, wind and ocean engineering, Elsevier Science book and journals, 2002.
- [Dwight, 1999] Dwight J.: Aluminium Design and Construction, E & FN SPON, London, 1999.
- [ECCS 66, 2000] European Recommendations for Sandwich Panels, Design, ECCS-TC7/CIB, Report N 257, Brussels, 2000.
- [Eligehausen, 1990] Eligehausen R.: Design of fastenings in concrete using partial safety factors, German, Bauingenier, No. 65, pp. 295-305, 1990.
- [Elremaily, Azizinamini, 2001a] Elremaily A., Azizinamini A.: Design provisions for connections between steel beams and concrete filled tube columns, Journal of Constructional Steel Research, Vol. 57, No. 9, pp. 971-995, 2001.
- [Elremaily, Azizinamini, 2001b] Elremaily A., Azizinamini A.: Experimental behaviour of steel beam to CFT column connections, Journal of Constructional Steel Research Vol. 57, No. 10, pp. 1099-1119, 2001.
- [El-Rimawi et al, 1997] El-Rimawi J.A., Burgess I.W., Plank R.J.: The Influence of Connections Stiffness and Behaviour of Steel Beams in Fire, Journal of Constructional Steel Research, Vol. 43 (1-3), pp. 1-15, 1997.
- [El-Tawil et al, 2000] El-Tawil S., Mikesell T., Kunnath S.K.: Effect of Local Details and Yield Ratio on Behaviour of FR Steel Connections, Journal of Structural Engineering, ASCE, Vol. 126, No.1, pp. 79-87, 2000.
- [ENV 1090-1, 1996] ENV 1090-1: Execution of steel structures –Part 1: General rules and rules for buildings, CEN, Brussels, 1996.
- [ENV 1992-1-1, 1992] ENV 1992-1-1: Design of Concrete Structures, Eurocode 2, European Pre-Standard, CEN, Brussels, 1992.
- [ENV 1993-1-1, 1992] ENV 1993-1-1, Design of steel structures, Eurocode 3, CEN, Brussels 1992, p. 370.
- [ENV 1999-1-1, 1999] ENV 1999-01-01: Design of Aluminium Structures, General rules and rules for buildings, CEN, Brussels, 1999.
- [ENV 1999-2, 1999] ENV 1999-2: Design of Aluminium Structures, Fatigue, CEN, Brussels, 1999.
- [Fan, 1995] Fan L.: Contribution to Steel Sheet Connections of Screws, Blind Rivets and Cartridge Fired Pins, Université de Liège, Faculté des Sciences Appliquées, These de doctorat, Liège, 1995.
- [Fisher, Struik, 1987] Fisher J. W., Struik J. H. A.: Guide to Design Criteria for Bolted and Riveted Joints, Wiley, Chichester, 1987.

- [Franssen, 2002] Franssen J.M.: Numerical determination of 3D temperature fields in steel joints, Second International Workshop “Structures in Fire”, Christchurch, 2002.
- [Gomes et al, 1994] Gomes F.C.T., Jaspert J.P., Maquoi R.: Behaviour of minor-axis joints and 3-D joints. COST C1 document, 26-28 October 1994.
- [Grecea, 2001] Grecea D.: Caractérisation du comportement sismique des ossatures métalliques, Colloque franco-roumain d’Ingénierie, Normalisation et Recherche en Construction Mixte Acier-Béton, Timișoara, 14-15 September 2001.
- [Hancock, 1998] Hancock G.J.: Design of Cold-Formed Steel Structures, Third edition, Australian Institute of Steel Construction, 1998
- [Hawkins, 1968a] Hawkins N.M.: The bearing strength of concrete loaded through rigid plates, Magazine of Concrete Research, Vol. 20, No. 63, pp. 31-40, March 1968.
- [Hawkins, 1968b] Hawkins N.M.: The bearing strength of concrete loaded through flexible plates, Magazine of Concrete Research, Vol. 20, No. 63, pp. 95-102, June 1968.
- [Huber, 1999] Huber G.: Non-linear calculations of composite sections and semi-continuous joint, Ernst & Sohn, Innsbruck 1999, pp. 346, ISBN 3-433-01250-4.
- [Huber, 2001] Huber G.: Semi-continuous beam-to-column joints at the Millennium Tower in Vienna, Austria, Steel and Composite Structures, Vol. 1, No. 2, pp. 159-170, 2001.
- [Chi et al, 2000] Chi W.M., Deierlein G.G., Ingraffea A.: Fracture Toughness Demands in Welded Beam-Column Moment Connections, Journal of Structural Engineering, ASCE, Vol. 126, No.1, pp. 88-97, 2000.
- [Jaspert, 1997] Jaspert J.P.: Recent advances in the field of steel joints – Column bases and further configurations for Beam-to Column Joints and Beam Splices, Thesis Université de Liège, Liège 1997.
- [Jaspert, 1991] Jaspert J.P.: Etude de la semi-rigidité des nœuds poutre-colonne et son influence sur la résistance des ossatures en acier. PhD Thesis, (in French), Department MSM, University of Liège, 1991.
- [Jaspert et al, 2003] Jaspert J.P., Renkin S., Guillaume M.L.: European Recommendations for the Design of Simple Joints in Steel Structures, 1st draft of a forthcoming publication of the Technical Committee 10 “Joints and Connections” of the European Convention of Constructional Steelwork (ECCS TC10) prepared at the University of Liège, September 2003.
- [Jaspert et al, 1999] Jaspert J.P., Braham M., Cerfontaine F.: Strength of joints subject to combined action of bending moments and axial forces, in Proceedings of the Conference Eurosteel '99, Vol. 2, CTU Prague, Prague 1999, pp. 465 – 468, ISBN 972-98376-3-5.
- [Kaitila et al, 2001] Kaitila O., Kesti J., Makelainen P.: The behaviour of a new type of connection system for light-weight steel structures applied to roof trusses, Steel & Composite Structures Vol. 1, No. 1, pp.17-32, Techno-Press, March 2001.
- [Kato, 1988] Kato B.: Bolted beam to column moment connections, CIDECT report No. 6 C-88/6, 1988.
- [Kirby, 1995] Kirby B. R.: The behaviour of high-strength grade 8.8 bolts in fire, Journal of Constructional Steel Research, Vol. 33 (1-2), pp. 3-37, 2001.
- [Kitipornchai et al, 1994] Kitipornchai S., Al-Bermani F.G.A., Peyrot A.H.: Effect of Bolt Slippage on Ultimate Behaviour of Lattice Structures, Journal of Structural Engineering, Vol. 120, No. 8, pp. 2281-2287, ASCE, August 1994.
- [Kolari K., 1999] Kolari K.: Load-Sharing of Press-Joints in Thin-Walled Steel Structures, Light-Weight Steel and Aluminium Structures, pp. 577-583, Elsevier Science Publishers Ltd., 1999.
- [Korol et al, 1993] Korol R.M., Ghobarah A., Mourad S.: Blind bolting W-shape beams to HSS columns, Journal of Structural Engineering, American Society of Civil Engineers, Vol. 119, No 12, pp. 3463-3481, 1993.
- [Kouhi, Kortessmaa, 1990] Kouhi J., Kortessmaa M.: Strength tests on bolted connection using high-strength steels (HSS steels) as a base material, VTT Research Notes 1185, Espoo, 1990.
- [Kruppa, 1976] Kruppa J.: Résistance au feu des assemblages par boulons haute résistance. C.T.I.C.M., Puteaux, 1976.
- [Kulak et al, 1974] Kulak G.L., Fisher J.W., Struik J.H.A.: Guide to design criteria for bolted and riveted joints, second edition, J. Wiley & Sons, New York, 1974.

- [Kuzmanovic, Willems, 1983] Kuzmanovic B., Willems N.: Steel Design for Structural Engineers, Prentice-Hall, Inc., New Jersey, 1983.
- [LaBoube, Yu, 1999] LaBoube R.A., Yu W.W.: New Design for Cold-Formed Steel Bolted Connections, Light-Weight Steel and Aluminium Structures, pp. 569-576, Elsevier Science Publishers Ltd., 1999.
- [Lawson, 1990] Lawson R.M.: Behaviour of steel beam-to-column connections in fire, The Structural Engineer, 68 (14), pp. 263-271, London, 1990.
- [Leston-Jones et al, 1997] Leston-Jones L.C., Burgess I.W., Lennon T., Plank R.J.: Elevated temperature moment-rotation test on steelwork connections, Proceedings of Institution of Civil Engineers, Structures & Buildings, 122 (4), pp. 410-419, 1997.
- [Liu, 1996] Liu T.C.H.: Finite element modeling of behaviour of steel beam and connections in fire, Journal of Constructional Steel Research, 36 (2), pp. 181-199, 1996.
- [Makelainen et al, 1999] Makelainen P., Kesti J., Lu W., Pasternak H., Komann S.: Static and Cyclic Shear Behaviour of the Rosette-Joint, Light-Weight Steel and Aluminium Structures, pp. 584-592, Elsevier Science Publishers Ltd., 1999.
- [Mao et al, 2001] Mao C., Ricles J., Lu L.W., Fisher J.: Effect of Local Details on Ductility of Welded Moment Connections, Journal of Structural Engineering, ASCE, Vol. 127, No.9, pp. 1036-1045, 2001.
- [Maquoi et al, 1984] Maquoi R., Naveau X., Rondal J.: Beam-column welded stud connections, Journal of Constructional Steel Research, Vol. 4, No. 1, 1984.
- [Mareš et al, 2000] Mareš J., Wald F., Sokol Z.: Modelling of Joints of sandwich panels, The Paramount Role of Joints into the Reliable Response of Structures, pp. 387-394, NATO Science Series, ed.: Baniotopoulos C.C., Wald, F., Series II, Vol. 4, Kluwer Academic Publishers, Dordrecht, 2000, ISBN 0-7923-6700-6.
- [Mazzolani, 2000] Mazzolani F.M.: Moment Resistant Connections of Steel Frames in Seismic Areas, E & FN Spoon, London 2000. ISBN 0-415-23577-4.
- [Mazzolani, 1995] Mazzolani F.M.: Aluminium Alloy Structures, E & FN SPON, London, 1995.
- [Moore, 1997] Moore D.B.: Full-scale fire tests on complete buildings, In: Fire, static and dynamics tests of building structures, Proceedings of the second Cardington Conference Cardington, ed.: Armer G.S.M., O'Dell T., E&FN SPON, 1997.
- [Murray, 1983] Murray T.M.: Design of Lightly Loaded Steel Column Base Plates, Engineering Journal AISC, Vol. 20, pp. 143-152, 1983.
- [Nair et al, 1974] Nair R.S., Birkemoe P.C., Munse W.H.: High Strength Bolts Subject to Tension and Prying, Journal of the Structural Division, ASCE, Vol. 100, No. ST2, pp. 351-372, February 1974.
- [Nakashima, 1998] Nakashima S.: Effects of floors on mechanical behaviours of steel column bases, in Proceedings of Nordic Steel Construction Conference 98, Vol. 2., pp. 467-474, Oslo, 1998.
- [Owens et al, 1999] Owens G.W., Nethercot D.A., Tizani W., Brown D.G., King C.M., Malik A.S., Taylor J.C.: The bearing capacity of Slotted Holes, Document RT755/02, CSI Ascot, 1999.
- [Owens, Cheal, 1989] Owens G.W., Cheal D.B.: Structural Steelwork Connections, Butterworths, 1989.
- [Oyj, Vainio, 2000] Oyj R., Vainio H.: Design Handbook for Rautaruukki Structural Hollow Sections, Hämeenlinna, 2000, ISBN 952-5010-47-3.
- [Piraprez, 2000] Piraprez E.: Behavior of plates with slotted holes, CRIF Belgium, in Proceeding of International Conference on Steel Structures of the 2000's, IABCE, Istanbul, 2000.
- [prEN 14509, 2002] Self-supporting double skin metal façade insulating sandwich panels, Factory made products, Specification, draft, CEN, Brussels 2002.
- [prEN 1990, 2001] prEN 1990, Eurocode - Basis of structural design, CEN, Brussels, 2001.
- [prNV 1992-1-1, 2003] prNV 1992-1-1: Design of concrete structures, Eurocode 2, European Standard, CEN, Brussels, 2003.
- [prEN 1993-1-2, 2003] prEN 1993-1-2. Eurocode 3: Design of steel structures, Part 1.2: General rules, Structural fire design, European Standard, CEN, Brussels 2003.
- [prEN 1993-1-3, 2003] prEN 1993-1-3: 2002. Eurocode 3: Design of steel structures, Part 1.3: General rules, Supplementary rules for cold-formed thin gauge members and sheeting, European Standard, CEN, Brussels, 2003.
- [prEN 1993-1-8: 2003] prEN 1993-1-8: 2003. Eurocode 3: Design of steel structures, Part 1.8: Design of joints, European Standard, CEN, Brussels, 2003.

- [prEN1993-1-9, 2003] prEN 1993-1-9: 2003: Eurocode 3: Design of steel structures, Part 1.9: Fatigue strength of steel structures, European Standard, CEN, Brussels, 2003.
- [prEN 1998-1, 2001] prEN 1998-1: Design of structures for earthquake resistance. Part 1: General rules, seismic actions and rules for buildings, European Standard, CEN, Brussels, 2001.
- [Sadri, 1994] Sadri S.: Blind bolting. Modern Steel Construction, American Institute of Steel Construction, pp. 44-46, February 1994.
- [Sakumoto et al, 1992] Sakumoto Y., Keira K., Furumura F., Ave T.: Tests of fire-resistance bolts and joints, Journal of Structural Engineering, 119 (11), pp. 3131-3150, 1993.
- [SCI recommendation, 1991] Steel Construction Industry Forum: Investigation of Broadgate phase 8 fire, The Steel Construction Institute, 1991.
- [SCI recommendation, 1990] The Steel Construction Institute: Enhancement of fire resistance of beams by beam-to-column connections, Technical report, SCI Publication 086, 1990.
- [Shelson, 1957] Shelson W.: Bearing Capacity of Concrete, Journal of the American Concrete Institute, Vol. 29, No. 5, pp. 405-414, November 1957.
- [Schneider, 1997] Schneider S.P.: Detailing Requirements for Concrete-Filled Steel Tubes Connections, Composite Construction – Conventional and Innovative, International Conference, Innsbruck, Austria, 16-18 September 1997, Composite Construction c/o IABSE, Zurich, Switzerland, 1997.
- [Schneider, Amidi, 1998] Schneider S.P., Amidi A.: Seismic Behaviour of Steel Frames with Deformable Panel Zones, Journal of Structural Engineering, ASCE, Vol. 124, No.1, pp. 35-42, 1998.
- [Simões da Silva et al, 2001] Simões da Silva L., Santiago A., Vila Real P.: A component model for the behaviour of steel joints at elevated temperatures, Journal of Constructional Steel Research, Vol. 57 (11), pp. 1169-1195, 2001.
- [Snijder et al, 6.01, 1988] Snijder H.H., Ungemann D., Stark J.W.B., Sedlacek G., Bijlaard F.S.K., Herment-Halswick A.: Evaluation of test results on welded connections in order to obtain strength functions and suitable model factor, BI-88-139, TNO 1988, Background document to Eurocode 3 doc. 601, 602, 605, p. 37, p. 25, p. 18.
- [Snijder et al, 6.04, 1988] Snijder H.H., Bijlaard F.S.K., Stark J.W.B.: Comparison of bolt strength according to Eurocode 3 with bolt strength according to national codes, Part A Results, Background documentation, BI-89-152, Delft, 1988.
- [Snijder et al, 6.05, 1988] Snijder H.H., Bijlaard F.S.K., Stark J.W.B.: Comparison of weld strength according to Eurocode No.3 with weld strength according to national codes, BI-89-011, Background document to Eurocode 3, doc. 6.05, p. 13, p. 28, TNO 1989.
- [Snijder et al, 1988] Snijder H.H., Ungemann D., Stark J.W.B., Sedlacek G., Bijlaard F.S.K., Herment-Halswick A.: Evaluation of test results on welded connections in order to obtain strength functions and suitable model factor, Background document to Eurocode 3, doc. 601, 602, 605, p. 37, p. 25, p. 18, BI-88-139, TNO, Delft, 1988.
- [Snijder et al, 1989] Snijder H.H., Bijlaard F.S.K., Stark J.W.B.: Comparison of weld strength according to Eurocode No.3 with weld strength according to national codes, Background document to Eurocode 3 doc. 605, p. 13, p. 28, BI-89-011, TNO, Delft, 1989.
- [Sokol, 2000] Sokol Z.: Tension part of column base, in Czech, research report CTU in Prague, Praha, 2000.
- [Sokol et al, 2002] Sokol Z., Wald F., Delabre V., Muzeau J.P., Švarc M.: Design of End Plate Joints Subject to Moment and Normal Force, In: Proceedings of Eurosteel 2002 Conference, Coimbra, 2002.
- [Spyrou et al, 2002] Spyrou S., Davison B., Burgess I., Plank R.: Component-based studies on the behaviour of steel joints at elevated temperatures, in Proceedings of Eurosteel 2002 – 3rd European Conference on Steel Structures, ed.: Lamas A., Simões da Silva L., pp. 1469-1478, Coimbra, 2002.
- [Stark, 2000] Stark J.W.B.: Performance Requirements for Preloaded Bolts in Structural Connections, 65th Anniversary Prof. Gunther Valtinat, ECCS TC10 Meeting, Timișoara, September 2001.
- [Stark, 1979] Stark J.W.B.: De berenkening van voetplaten van stalen kolommen, in Dutch, Bouwen met staal, No. 49, pp. 21-28, September 1979.
- [Stark, Bijlaard, 1988] Stark J.W.B., Bijlaard F.S.K.: Eurocode 3 - Appendix 6C - Column Bases, TNO Rapport BI-88-094, Delft, 1988.

- [Steenhuis, 1999] Steenhuis M.: Momentverbindingen, SG/TC10a, Stalbouwkundig Genootschap, Rotterdam 1999, ISBN 90-72830-29-6.
- [Steenhuis, 1998a] Steenhuis M.: Normaalkrachtverbindingen, dwarskrachtverbindingen, SG/TC10a, Stalbouwkundig Genootschap, Rotterdam, 1998, ISBN 90-72830-24-5.
- [Steenhuis, 1998b] Steenhuis C. M.: Assembly Procedure for Base Plates, TNO Building and Construction Research Report 98-R-0477, Delft, 1998.
- [Stockwell, 1987] Stockwell F.W. Jr.: Base Plate Design, AISC, National Engineering Conference Proceedings, Paper 49, April/May 1987.
- [Stockwell, 1975] Stockwell F.W. Jr.: Preliminary Base Plate Selection, Engineering Journal AISC, Vol. 21, No. 3, pp. 92-99, 1975.
- [Tizani, 1999] Tizani W.: The bearing capacity of plates made with long-slotted bolt holes, report, p. 58, University of Nottingham, SCI No. SCR 99002, London, 1999.
- [Toma et al, 1993] Toma A., Sedlacek G., Weynand K.: Connections in Cold-Formed Steel, Thin-Walled Structures, Vol. 22, No. 16, pp. 219-237, Elsevier Science Publishers Ltd., 1993.
- [Trahair et al, 2001] Trahair N.S., Bradford M.A., Nethercot D.A.: The Behaviour and Design of Steel Structures to BS5950, Spon Press, London, 2001.
- [Wald, 1999] Wald F.: Column and Anchor Bolts, Festschrift Commerative Publikation to Ferdinand Tschemmerneegg, Institut für Stahlbau, Holzbau und Michbautechnologie, ed.: Huber G., Michl T., pp. 317-330, Innsbruck, 1999, ISBN 3-9501069-0-1.
- [Wald, 1995] Wald F.: Patky sloupů, Column Bases, CTU in Prague, Praha, 1995, ISBN 80-01-01337-5.
- [Wald, Baniotopoulos, 1998] Wald F., Baniotopoulos C.C.: Numerical modelling of column base connection, In: COST C1 Conference Liège 1998, ed. Maquoi R., pp. 497-507, Brussels 1999, ISBN 92-828-6337-9.
- [Wald et al, 2002a] Wald F., Mazura V., Moal V., Sokol Z.: Experiments of bolted cover plate connections with slotted holes, CTU reports, Vol. 2, 2/2002, pp. 79-97, CUT, Praha, 2002, ISBN 80-01-02536-8.
- [Wald et al, 2002b] Wald F., Sokol Z., Moal M., Mazura V., Muzeau J. P.: Stiffness of cover plate connections with slotted holes, Eurosteel 2002, pp. 1007-1016, Coimbra, 2002, ISBN 972-98376-3-5.
- [Wald et al, 2001] Wald F. et al: Steel structures 10, Worked examples to Eurocode 3, Czech Technical University in Prague, Prague 2001, p. 146, ISBN 80-01-02308-7.
- [Wald et al, 2000] Wald F., Bouguin V., Sokol Z., Muzeau J.P.: Component Method for Base Plate of RHS, in Proceedings of the Conference Connections in Steel Structures IV: Steel Connections in the New Millennium, Roanoke, 2000.
- [Wald, Jaspert, 1999] Wald F., Jaspert J.P.: Column Bases in Steel Building Frames, in COST C1, Semi-rigid behaviour of structural steel connections, ed. Weynand K., Brussels, 1999.
- [Wald et al, 1998] Wald F., Gresnigt A.M., Weynand K., Jaspert J.P.: Application of the Component Method to Column Bases, In: Proceedings of COST C1 Conference Liège 1998, ed.: Maquoi R., pp. 155-166, Brussels, 1999, ISBN 92-828-6337-9.
- [Wald, Steenhuis, 1993] Wald F., Steenhuis M.: The Beam-to-Column Bolted Joint Stiffness according Eurocode 3, in Proceedings of the State of the Art, Workshop 1992 - COST C1, Strasbourg 1993, pp. 503 - 516.
- [Wong, Chung, 2002] Wong M.F., Chung K.F.: Structural behaviour of bolted moment connections in cold-formed steel beam-column sub-frames, Journal of Constructional Steel Research No.58, pp. 253-274, Elsevier Science Publishers Ltd., 2002.
- [Yeomans, 2002] Yeomans N.F.: Guide on the use of bolts: Single sided (blind) bolting systems, ECCS-TC10-01-WG3/188 (revised), 2002.
- [Yeomans, 1998] Yeomans N.F.: Rectangular hollow section column connections using the Lindapter HolloBolt. Tubular Structures VIII, ed.: Choo, van der Vegte, pp. 559-566, Balkema, Rotterdam, 1998.
- [Yu, 2000] Yu W.W.: Cold-Formed Steel Design, John Wiley & Sons, 2000.
- [Zoetemeijer, 1990] Zoetemeijer P.: Summary of the research on bolted beam-to-column connections, TU-Delft report 26-6-90-2, Delft, 1990.
- [Zoetemeijer, 1983a] Zoetemeijer P.: Proposal for Standardisation of Extended End Plate Connection based on Test results - Test and Analysis, Rep. No. 6-83-23, Steven Laboratory, Delft, 1983.

- [Zoetemeijer, 1983b] Zoetemeijer P.: Summary of the Research on Bolted Beam-to-Column Connections (period 1978 - 1983), Rep. No. 6-85-M, Steven Laboratory, Delft, 1983.
- [Zoetemeijer, 1974] Zoetemeijer P.: A Design Method for the Tension Side of Statically Loaded Bolted Beam-to-Column Connections, Heron, No. 20 (1), Delft, 1974.



Education and Culture

Leonardo da Vinci

Design of Structural Connections to Eurocode 3 – Frequently Asked Questions

Ed. Moore D.B., Wald F.

www.fsv.cvut.cz/cestruco

ISBN 80-01-02838-0

Building Research Establishment Ltd, Watford

Printed at Prod. Dept. of Publishing House of Czech Technical University in Prague

September 2003

1500 copies, 140 pages, 154 figures

Textbook, Work Package Dissemination

Project Continuing Education in Structural Connections

No. CZ/00/B/F/PP-134049

LEONARDO DA VINCI PROGRAMME

This project has been carried out with the support of the European Community.

The content of this project does not necessarily reflect the position of the European Community or the National Agency, nor does it involve any responsibility on their part.