

FACULTY OF CIVIL ENGINEERING, CTU IN PRAGUE

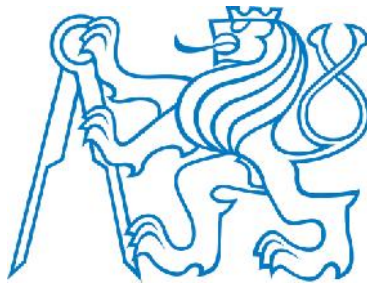

Commented example of combined precast and in- situ reinforced concrete slab design

Educational material

Ing. Josef Fládr

1.12.2012

This document was created under the financial support of FRVŠ 239/2012/G1 project „Navrhování betonových a zděných prvků při dočasných návrhových situacích“ („Design of concrete and masonry members in temporary design situations“).

1. Assignment

The goal of this commented example is to make the students of Faculty of Civil Engineering, CTU in Prague familiar with the design procedure of combined precast and in-situ slabs. Design of load-bearing members is shown also with respect to assembling stages of particular precast elements of the slab. The aim of the commented example is to show the complexity of structural design.

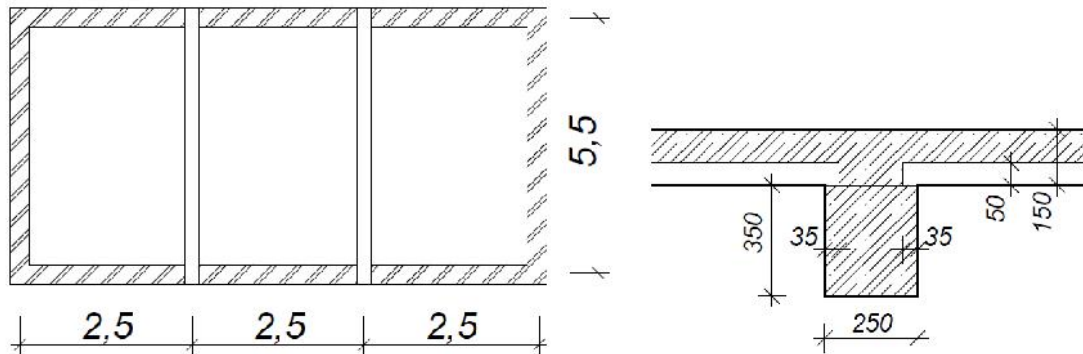

Fig. 1 Scheme of the structure

2. Design of the structure for service life

At the first step, the structure will be design for the loads that affect it during its service life, because these loads are the dominant ones.

2.1. Loading of the slab

Permanent	Thickness [mm]	Bulk density [kg/m ³]	Char. load [kN/m ²]	Partial factor	Design load [kN/m ²]
Ceramic tiles	8	2000	0,16	1,35	0,22
Flexible cement	2	2100	0,04	1,35	0,06
Concrete	100	2500	2,50	1,35	3,38
Self-weight	150	2500	3,75	1,35	5,06
Plaster	15	1800	0,27	1,35	0,36
Total of permanent load			Σ 6,72	Σ	9,07
Variable					
Category C4: Areas for physical activities			5,00	1,5	7,5
Removable partitions, weight < 3,0 kN/m			1,20	1,5	1,8
Total of variable			Σ 6,20	Σ	9,3
TOTAL			12,92		18,4

2.2. Calculation of cover depth

Description of the structure

- The structure is inside the building, with low-humidity operations => **XC1**
- The surface is not exposed to corrosion caused by chlorides
- The surface is not in contact with sea water
- The structure is protected, therefore is not exposed to freeze-thaw cycles
- There is no risk of chemical attack of the structure
- Slab-like structure

Requirements: XC1 C 30/37; w/c < 0,6, c > 260 kg/m³
Serviceability life 50 years => structural class **S4**

$$c_{nom} = c_{min} + U c_{dev}$$

$$c_{min} = \max \{ c_{min,b}; c_{min,dur} + c_{dur}, - c_{dur,st} - c_{dur,add}; 10 \text{ mm} \}$$

$$c_{min,b} = 10 \text{ mm (estimated diameter of rebars)}$$

$$c_{min,dur} = 10 \text{ mm}$$

Values of $c_{min,dur}$ [mm]							
Structural class	Exposure class related to environmental conditions						
	X0	XC1	XC2/XC3	XC4	XD1/XS1	XD2/XS2	XD3/XS3
S1	10	10	10	15	20	25	30
S2	10	10	15	20	25	30	35
S3	10	10	20	25	30	35	40
S4	10	15	25	30	35	40	45
S5	15	20	30	35	40	45	50
S6	20	25	35	40	45	50	55

$c_{dur}, ; c_{dur,st}; c_{dur,add}$ considered equal to 0
 $c_{min,st} = \max \{ 10; 100 + 0 - 0 - 0; 10 \} = 10 \text{ mm}$
 $U c_{dev} = 10 \text{ mm (precast structure)}$
 $c_{nom,st} = c_{min,st} + U c_{dev} = 10 + 10 = 20 \text{ mm}$

2.3. Material characteristics

CONCRETE C 30/37 =>

$$f_{ck} = 30 \text{ MPa}$$

$$f_{cd} = \frac{30}{1,5} = 20,0 \text{ MPa}$$

$$f_{cm} = 2,9 \text{ MPa}$$

$$f_{ctk0,05} = 2,0 \text{ MPa}$$

$$v_{cu3} = 3,5\%$$

STEEL B500B =>

$$f_{yk} = 500 \text{ MPa}$$

$$f_{yd} = \frac{500}{1,15} = 434 \text{ MPa}$$

$$E_s = 200\,000 \text{ MPa}$$

$$v_s = \frac{f_{yd}}{E_s} = \frac{434}{200\,000} = 2,174\%$$

$$\epsilon_{bal} = \frac{v_{cu3}}{v_{cu3} + v_s} = \frac{3,5}{3,5 + 2,174} = 0,616$$

Moment curve

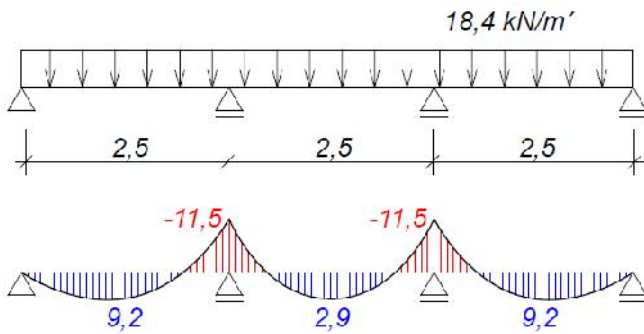

In final stage, filigree panels act as continuous beam. Therefore it is necessary to place upper reinforcement above the supports (beams). This reinforcement will be placed into the slab during casting of in-situ part of the structure.

2.4. ULS design of reinforcement – final design load

- Design of midspan reinforcement (*positive moment*)

Estimated diameter of rebars $\text{Ø} 8$

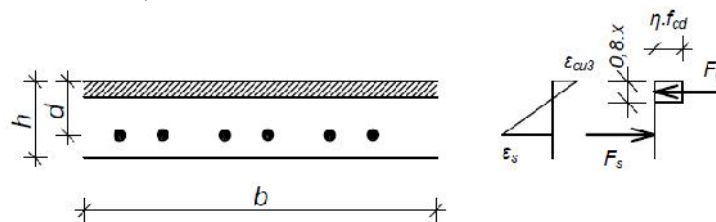

Fig. 2 Distribution of internal forces in slab (positive moment)

$$d = h - c - \text{Ø}/2 = 150 - 20 - 8/2 = 126 \text{ mm}$$

$$\xi = \frac{m_{Ed}}{b \cdot d_1^2 \cdot \eta \cdot f_{cd}} = \frac{9,2}{1,0 \cdot 0,126^2 \cdot 1,0 \cdot 20,0 \cdot 10^3} = 0,0289 \Rightarrow \xi' = 0,980$$

$$\kappa = 0,038$$

$$\kappa < 0,038 \leq 0,45 = \kappa_{lim} \Rightarrow \sigma_s = f_{yd}$$

$$A_{s,req} = \frac{m_{Ed}}{f_{yd} \cdot \eta \cdot d} = \frac{9,2 \cdot 10^6}{434,7 \cdot 10^3 \cdot 0,98 \cdot 0,126} = 171,4 \text{ mm}^2$$

Design: Ø8 per 150 mm ($A_{s,prov} = 335 \text{ mm}^2$)

Check of spacing (*using detailing rules*)

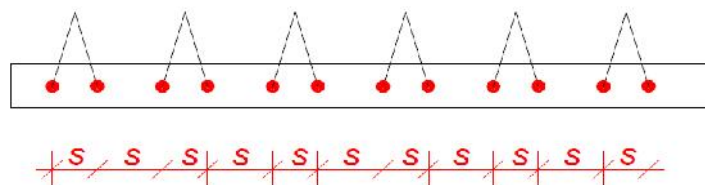

Fig. 3 Example of arrangement of lower reinforcement

$$s_{prov} = 150 \text{ mm}$$

$$s_{max,1} = 2 \cdot h = 2 \cdot 150 = 300 \text{ mm}$$

$$s_{max,2} = 300 \text{ mm}$$

$$s_{max} = \min(s_{max,1}; s_{max,2}) = 300 \text{ mm}$$

$$s_{min} = \max(1,2W; d_g + 5; 20\text{mm}) = \max(1,2 \cdot 8; 22 + 5; 20) \Rightarrow s_{min} = 27 \text{ mm}$$

(d_g maximum diameter of aggregate grains)

$$s_{\min} \leq s_{prov} \leq s_{\max}$$

$$\underline{27 \text{ mm} \leq 150 \text{ mm} \leq 300 \text{ mm}} \quad \text{CHECKED}$$

Check of minimum cross-sectional area of reinforcement

$$A_{s,prov} = 335 \text{ mm}^2$$

$$A_{s,max} = 0,04 \cdot A_c = 0,04 \cdot 150 \cdot 1000 = 6 \ 000 \text{ mm}^2$$

$$A_{s,min} = \frac{0,26 \cdot f_{ctm} \cdot b_t \cdot d}{f_{yk}} = \frac{0,26 \cdot 2,9 \cdot 1000 \cdot 126}{500} = 190,0 \text{ mm}^2$$

$$A_{s,min} \geq 0,0013 \cdot b_t \cdot d = 0,0013 \cdot 1000 \cdot 126 = 163,8 \text{ mm}^2$$

$$A_{s,min} \leq A_{s,prov} \leq A_{s,max}$$

$$\underline{190,0 \leq 335 \leq 6 \ 000} \quad \text{CHECKED}$$

Check of reinforcement for ultimate limit state (ULS)

$$x = \frac{A_{s,prov} \cdot f_{yd}}{b \cdot y \cdot f_{cd}} = \frac{335 \cdot 434,7}{0,8 \cdot 1000 \cdot 1,0 \cdot 20,0} = 9,1 \text{ mm}$$

$$\xi = \frac{x}{d} = \frac{9,1}{126} = 0,072 \leq 0,45 = \xi_{lim}$$

$$z = d - 0,5 \cdot x = 0,126 - 0,5 \cdot 0,0091 = 0,121 \text{ m}$$

$$m_{Rd} = a_{s,prov} \cdot f_{yd} \cdot z = 335 \cdot 434,7 \cdot 10^{-3} \cdot 0,121 = 17,69 \text{ kNm}$$

$$\underline{m_{Rd} = 17,69 \text{ kNm} \geq 9,2 \text{ kNm} = m_{Ed}} \quad \text{CHECKED}$$

reserve 92%

- Reinforcement in support (*negative moment*)

We choose $\varnothing 10$ *diameter of upper reinforcement is usually one or two levels higher than for lower reinforcement*

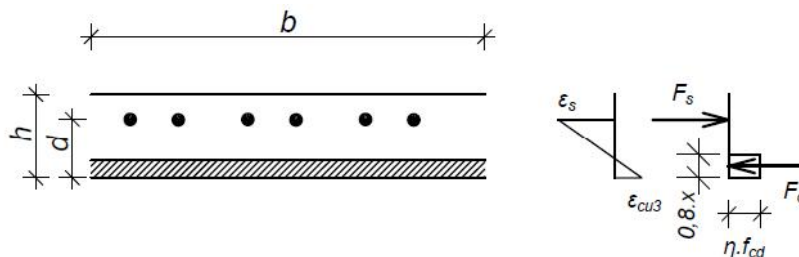

Fig. 4 Distribution of internal forces in slab (negative moment)

$$d = h - c - \varnothing / 2 = 150 - 20 - 10 / 2 = 125 \text{ mm}$$

$$\xi = \frac{m_{Ed}}{b \cdot d^2 \cdot y \cdot f_{cd}} = \frac{11,48}{1,0 \cdot 0,125^2 \cdot 1,0 \cdot 20,0 \cdot 10^3} = 0,037 \Rightarrow \xi = 0,982$$

$$= 0,045$$

$$\xi = 0,045 \leq 0,45 = \xi_{lim} \Rightarrow \sigma_s = f_{yd}$$

$$A_{s,req} = \frac{m_{Ed}}{f_{yd} \cdot \eta \cdot d} = \frac{11,48 \cdot 10^6}{434,7 \cdot 10^3 \cdot 0,982 \cdot 0,125} = 215,2 \text{ mm}^2$$

Design: $\varnothing 10$ per 300 mm ($A_{s,prov} = 262 \text{ mm}^2$)

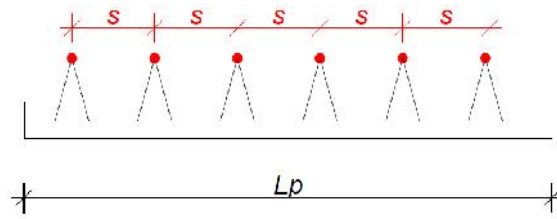

Fig. 5 Example of arrangement of upper reinforcement

Check of spacing

$$s_{prov} = 300 \text{ mm}$$

$$s_{max,1} = 2 \cdot h = 2 \cdot 150 = 300 \text{ mm}$$

$$s_{max,2} = 300 \text{ mm}$$

$$s_{max} = \min(s_{max,1}; s_{max,2}) = 300 \text{ mm}$$

$$s_{min} = \max(1,2W; d_g + 5; 20\text{mm}) = \max(1,2 \cdot 10; 22 + 5; 20) \Rightarrow s_{min} = 27 \text{ mm}$$

(d_g maximum diameter of aggregate grains)

$$s_{min} \leq s_{prov} \leq s_{max}$$

$$27 \text{ mm} \leq 300 \text{ mm} \leq 300 \text{ mm} \quad \text{CHECKED}$$

Check of minimum cross-sectional area of reinforcement

$$A_{s,prov} = 262 \text{ mm}^2$$

$$A_{s,max} = 0,04 \cdot A_c = 0,04 \cdot 150 \cdot 1000 = 6000 \text{ mm}^2$$

$$A_{s,min} = \frac{0,26 \cdot f_{ctm} \cdot b_t \cdot d}{f_{yk}} = \frac{0,26 \cdot 2,9 \cdot 1000 \cdot 125}{500} = 188 \text{ mm}^2 \quad (\text{brittle failure})$$

$$A_{s,min} \geq 0,0013 \cdot b_t \cdot d = 0,0013 \cdot 1000 \cdot 125 = 163 \text{ mm}^2 \quad (\text{reinforcement ratio})$$

$$A_{s,min} \leq A_{s,prov} \leq A_{s,max}$$

$$188 \leq 262 \leq 6000 \quad \text{CHECKED}$$

Check of reinforcement in ultimate limit state (ULS)

$$x = \frac{A_{s,prov} \cdot f_{yd}}{b \cdot y \cdot f_{cd}} = \frac{262 \cdot 434,7}{0,8 \cdot 1000 \cdot 1,0 \cdot 20,0} = 7,1 \text{ mm}$$

$$\xi = \frac{x}{d} = \frac{7,1}{125} = 0,056 \leq 0,45 = \xi_{lim}$$

$$z = d - 0,5 \cdot x = 125 - 0,5 \cdot 7,1 = 121,25 \text{ mm} = 0,121 \text{ m}$$

$$m_{Rd} = A_{s,prov} \cdot f_{yd} \cdot z = 262 \cdot 434,7 \cdot 0,121 = 13,83 \text{ kNm}$$

$$m_{Rd} = 13,83 \text{ kNm} \geq 11,48 \text{ kNm} = m_{Ed} \quad \text{CHECKED}$$

reserve 20%

2.5. SLS check of panel

For the purpose of this example, serviceability limit state will be checked using simplified method based on deflection control criterion.

Concrete class: **C 30/37**

Type of structure: **continuous beam** \longrightarrow $d_{,tab} = 30,8$ pro = 0,5%

$A_{s,prov} = 335 \text{ mm}^2$ (*lower reinforcement is crucial for deflections*) $d_{,tab} = 21,0$ pro = 1,5%

$A_{s,req} = 171 \text{ mm}^2$ (*required cross-sectional area of reinforcement from ULS*)

Span: $l = 2,5 \text{ m}$

Reinforcement ratio $= A_{s,prov} / A_c = 335 / (1000 \cdot 150) = 0,22 \%$

As the reinforcement ratio of our panel is less than 0,5 %, $d_{,tab}$ can be taken as 30,8 and no interpolation is required.

$$d_{,tab} = 30,8 \text{ pro} = 0,5\%$$

$$c1 = 1,0 \text{ (rectangular cross-section)}$$

$$c2 = 1,0 \text{ (span is less than 7,0 m)}$$

$$c3 = \frac{500}{f_{yk}} \cdot \frac{A_{s,prov}}{A_{s,req}} = \frac{500}{500} \cdot \frac{335}{171} = 1,96$$

$$d = c1 \cdot c2 \cdot c3 \cdot d_{,tab} = 1,0 \cdot 1,0 \cdot 1,96 \cdot 21,00 = \underline{\underline{41,16}} -$$

$$l/d = 2,5 / 0,126 = \underline{\underline{19,84}} -$$

$$l/d < d$$

$$\underline{\underline{19,84}} < \underline{\underline{41,16}} \Rightarrow \text{Checked}$$

3. Check of the beam

3.1. Calculation of cover depth

Description of the structure

- The structure is inside the building, with low-humidity operations \Rightarrow **XC1**
- The surface is not exposed to corrosion caused by chlorides
- The surface is not in contact with sea water
- The structure is protected, therefore is not exposed to freeze-thaw cycles
- There is no risk of chemical attack of the structure

Requirements: XC1 C 30/37; w/c < 0,6, c > 260 kg/m³

Serviceability life 50 years \Rightarrow structural class **S4**

- Cover depth for stirrups

$$c_{nom} = c_{min} + U c_{dev}$$

$$c_{min} = \max \{ c_{min,b}; c_{min,dur} + c_{dur} - c_{dur,st} - c_{dur,add}; 10 \text{ mm} \}$$

$$c_{min,b} = 8 \text{ mm (estimated diameter of stirrups)}$$

$$c_{min,dur} = 10 \text{ mm}$$

Values of $c_{min,dur}$ [mm]							
Structural class	Exposure class related to environmental conditions						
	X0	XC1	XC2/XC3	XC4	XD1/XS1	XD2/XS2	XD3/XS3
S1	10	10	10	15	20	25	30
S2	10	10	15	20	25	30	35
S3	10	10	20	25	30	35	40
S4	10	15	25	30	35	40	45
S5	15	20	30	35	40	45	50
S6	20	25	35	40	45	50	55

c_{dur} ; $c_{dur,st}$; $c_{dur,add}$ considered equal to 0
 $c_{min,st} = \max\{8; 10 + 0 - 0 - 0; 10\} = 20 \text{ mm}$
 $U_{c_{dev}} = 10 \text{ mm}$ (*precast structure*)
 $c_{nom,st} = c_{min,st} + U_{c_{dev}} = 10 + 10 = 20 \text{ mm}$

- Cover depth for main bending reinforcement

$c_{nom} = c_{min} + U_{c_{dev}}$
 $c_{min} = \max\{c_{min,b}; c_{min,dur} + c_{dur} - c_{dur,st} - c_{dur,add}; 10 \text{ mm}\}$
 $c_{min,b} = 22 \text{ mm}$ (*estimated diameter of rebars*)
 $c_{min,dur} = 10 \text{ mm}$
 c_{dur} ; $c_{dur,st}$; $c_{dur,add}$ considered equal to 0
 $c_{min,st} = \max\{22; 10 + 0 - 0 - 0; 10\} = 22 \text{ mm}$
 $U_{c_{dev}} = 5 \text{ mm}$ (*precast structure*)
 $c_{nom,st} = c_{min,st} + U_{c_{dev}} = 22 + 5 = 27 \quad 30 \text{ mm}$

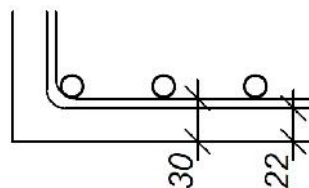

3.2. Design of main bending reinforcement in midspan

- Calculation of loads

$(18,4 \cdot 2,5 + 0,25 \cdot 0,35 \cdot 25 \cdot 1,35) = 48,9 \text{ kN/m'}$

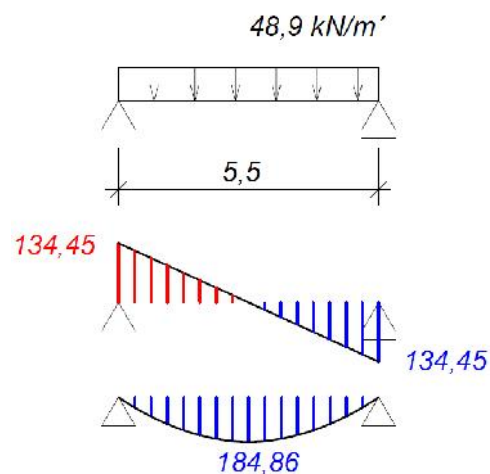

Slab is supported by masonry walls, therefore it acts as a simple beam.

The beam is loaded by the load from the slab multiplied by loading width of the beam (axial span in our case) + the self weight of part of the beam under the slab.

$M_{Ed, \text{midspan}} = 184,86 \text{ kNm}$

We choose Ø22

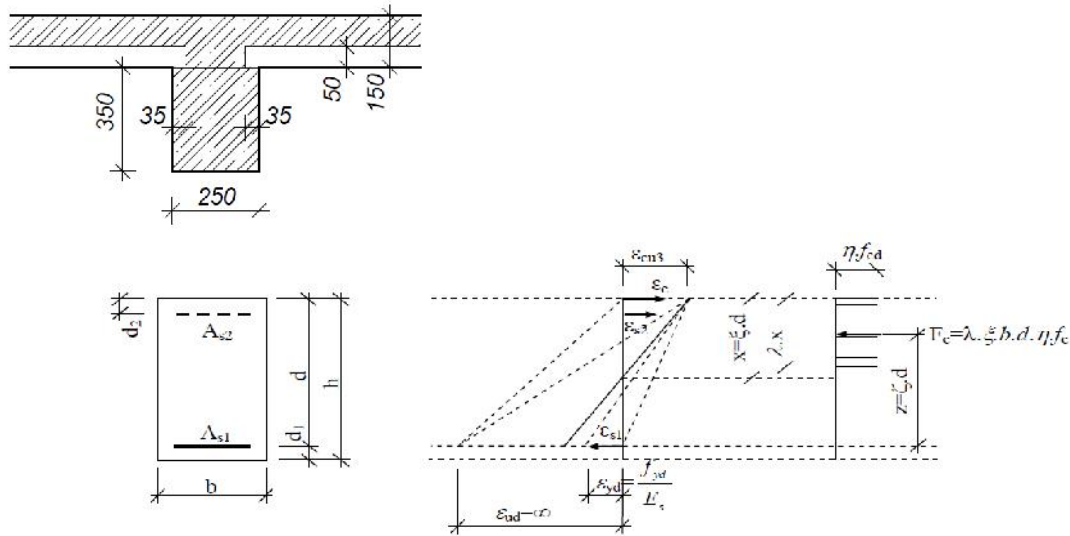

Fig. 6 Distribution of internal forces in beam (positive moment)

$$d = h - c - \frac{22}{2} = 500 - 30 - \frac{22}{2} = 459 \text{ mm (In final design state, beam collaborates with slab)}$$

$$\sim = \frac{M_{Ed}}{b \cdot d^2 \cdot f_{cd}} = \frac{184,86}{0,25 \cdot 0,459^2 \cdot 20 \cdot 0,10^3} = 0,175 \Rightarrow \begin{aligned} &= 0,245 \\ &\zeta = 0,902 \end{aligned}$$

$$= 0,245 \quad 0,45 = \lim \quad \text{CHECKED}$$

$$A_{s,req} = \frac{M_{Ed}}{f_{yd} \cdot g \cdot d} = \frac{184,86 \cdot 10^3}{434 \cdot 10^6 \cdot 0,902 \cdot 0,459} = 1028 \text{ mm}^2$$

Check of reinforcement ratio

$$A_{s,prov} = 1140 \text{ mm}^2$$

$$A_{s,max} = 0,04 \cdot A_c = 0,04 \cdot 500 \cdot 250 = 5000 \text{ mm}^2$$

$$A_{s,min} = \frac{0,26 \cdot f_{ctm} \cdot b_w \cdot d}{f_{yk}} = \frac{0,26 \cdot 2,9 \cdot 250 \cdot 459}{500} = 173 \text{ mm}^2$$

$$A_{s,min} \geq 0,0013 \cdot b_w \cdot d = 0,0013 \cdot 250 \cdot 459 = 149 \text{ mm}^2$$

$$A_{s,min} \leq A_{s,prov} \leq A_{s,max}$$

$$173 \leq 1140 \leq 5000 \quad \text{CHECKED}$$

Check of spacing

$$s_{prov} = \frac{b_w - 2 \cdot c - n \cdot W}{n - 1} = \frac{250 - 2 \cdot 30 - 3 \cdot 22}{2} = 62 \text{ mm}$$

$$s_{min} = \max(1,2W; d_g + 5; 20 \text{ mm}) = \max(1,2 \cdot 22; 16 + 5; 20) \Rightarrow s_{min} = 26,4 \text{ mm}$$

(d_g maximum diameter of aggregate grains)

$$s_{min} \leq s_{prov} \leq s_{max}$$

$$26,4 \text{ mm} \leq 62 \text{ mm} \quad \text{CHECKED}$$

Check of reinforcement in ultimate limit state (ULS)

Design: 3Ø22 ($A_{s,prov} = 1140 \text{ mm}^2$)

$$x = \frac{A_{sd} \cdot f_{yd}}{0,8 \cdot b \cdot f_{cd}} = \frac{1140 \cdot 10^{-6} \cdot 434}{0,8 \cdot 0,25 \cdot 20,0} = 124 \text{ mm}$$

$$\kappa = \frac{x}{d} = \frac{0,124}{0,459} = 0,270 \leq 0,45 = \kappa_{lim} \quad \text{CHECKED}$$

$$z = d - 0,4 \cdot x = 459 - 0,4 \cdot 124 = 409 \text{ mm}$$

$$M_{Rd} = A_s \cdot f_{yd} \cdot z = 1140 \cdot 10^{-6} \cdot 434 \cdot 0,409 = 194,32 \text{ kNm}$$

$$M_{Rd} = 194,32 \text{ kNm} \geq 184,86 \text{ kNm} = M_{Ed} \quad \text{CHECKED}$$

reserve 5%

3.3. Design of shear reinforcement

$V_{Ed} = 134,4 \text{ kNm}$ (*maximum value of shear force*)

Capacity of compressed concrete strut

$\cot \alpha = 1,5$ (*recommended value for optimum slope of shear cracks*)

$$v = 0,6 \left(1 - \frac{f_{ck}}{250} \right) = 0,6 \cdot \left(1 - \frac{30}{250} \right) = 0,528$$

$$V_{Rd,max} = v \cdot f_{cd} \cdot b_w \cdot z \cdot \frac{\cot \alpha}{1 + \cot^2 \alpha} = 0,528 \cdot 20,0 \cdot 0,25 \cdot 0,409 \cdot \frac{1,5}{1 + 1,5^2} = 356,9 \text{ kN}$$

Design of stirrups

Ø 8
number of legs 2
s 150 mm
 $f_{y,wk}$ 500 MPa

(maximum load-bearing capacity of concrete in compression perpendicular to anticipated shear crack)

$$\dots_{w,min} = 0,08 \cdot \frac{\sqrt{f_{ck}}}{f_{y,wk}} = 0,08 \cdot \frac{\sqrt{30}}{500} = 0,00088$$

$$s_{1,max} = \frac{A_{sw}}{b_w \dots_{w,min}} = \frac{2 \cdot 50,6}{250 \cdot 0,00088} = 460 \text{ mm}$$

$$s_{2,max} = \min(0,75 \cdot d; 400) = 0,75 \cdot 459 = 344 \text{ mm}$$

$$s_{max} = \min(460; 344) = 344 \text{ mm} \quad \text{(maximum spacing of stirrups according to detailing rules)}$$

$$s_{prov} = 150 \text{ mm} \leq 344 \text{ mm} = s_{max} \quad \text{CHECKED}$$

$$V_{Rd,s} = \frac{n \cdot A_{sw} \cdot f_{ywd}}{s} \cdot z \cdot \cot \theta = \frac{4,50 \cdot 26.500 / 1,15}{150} \cdot 459 \cdot 1,5 = 171,4 \text{ kN}$$

$$V_{Ed} = 134,4 \text{ kN} \leq 171,4 \text{ kN} = V_{Rd} \leq 356,9 \text{ kN} = V_{Rd,max}$$

CHECKED
reserve 27%

3.4. Connection

In case of full connection between beam and slab, the strain in critical cross-section is continuous up to the stage when limit elastic state of the cross-section is reached. This situation can be best characterized as a stage when yield limit of tensile reinforcement is reached (the strain of reinforcement is ϵ_{sy}). Load-bearing capacity of such cross-section is given by force couple N_c and N_{sy} with lever arm z .

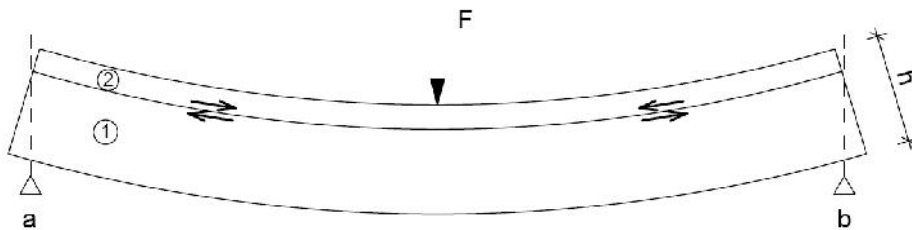

Fig. 6 Behavior of two fully connected members subjected to bending

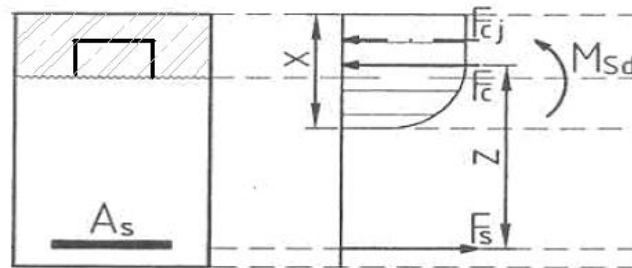
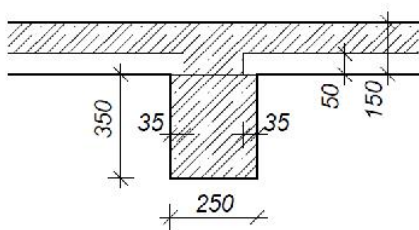

Fig. 7 Distribution of internal forces in precast and in-situ part of the cross-section.

$$b_i = b_w - 2 \cdot u_p = 250 - 2 \cdot 35 = 180 \text{ mm (effective width of the beam for transmission of shear stress between precast and in-situ part of the structure)}$$



Minimum bedding length of filigree panel on the beam is 35 mm. From technological point of view, even smaller values are possible, but temporary linear support right next to the beam is required in such a case. This option requires a way of support different from the one shown in this example.

Reduction of shear forces (for optimization of results)

$$V_{Ed,1} = V_{Ed} - \left(\left(\frac{b}{2} + d \right) \cdot (g + q)_d \right) = 134,45 - \left(\left(\frac{0,250}{2} + 0,459 \right) \cdot (48,9) \right) = 105,9 \text{ kN}$$

$$v_{Ed} = \frac{S \cdot V_{Ed,1}}{z \cdot b_i} = \frac{1,0 \cdot 105,9 \cdot 10^3}{409 \cdot (250 - 2 \cdot 35)} = 1,43 \text{ MPa}$$

S is ratio between longitudinal force in in-situ part of cross-section and total longitudinal force in compressed part of cross-section, in our case S = 1,0, because neutral axis lays in in-situ part of cross-section (see check of beam),

z is lever arm of internal forces (see check of beam),

b_i is width of connection area between in-situ and precast concrete members,

$$v_{Rd} = c \cdot f_{ctd} + \sim \cdot \dagger_n + \dots \cdot f_{yd} \cdot (\sim \cdot \sin \alpha + \cos \alpha) \leq 0,5 \cdot \epsilon \cdot f_{cd}$$

Connection type: rough connection

c = 0,45 ; μ = 0,7

where:

c, ~ are coefficients depending of roughness of connection area,

f_{ctd} is design tensile strength of concrete calculated from characteristic strength f_{ctk,0.05}

†_n is normal stress perpendicular to connection area, in our case we take †_n = 0,

...1 is reinforcement ratio of connection area by connecting members,

α is angle between connecting reinforcement and shear plane, in our case reinforcement will be perpendicular to concrete surface and therefore α = 90°,

v is reduction factor for compressive strength of concrete in shear, $\epsilon = 0,6 \left(1 - \frac{f_{ck}}{250} \right)$

$$\epsilon = 0,6 \cdot \left(1 - \frac{30}{250} \right) = 0,528$$

$$v_{Rd} = 0,45 \cdot \frac{2,0}{1,5} + 0,7 \cdot 0 + \frac{100,5 \cdot 6,66}{250 \cdot 1000} \cdot 434,7 \cdot (0,7 \cdot 1 + 0) \leq 0,5 \cdot 0,528 \cdot 20$$

$$v_{Rd} = 1,45 \text{ MPa} \leq 5,28 \text{ MPa} \quad \text{CHECKED}$$

$$v_{Ed} = 1,43 \text{ MPa} \leq 1,45 \text{ MPa} = v_{Rd} \quad \text{CHECKED}$$

4. Temporary design situations

4.1. Design of lifting clutches of the beam

$$F_p = V \cdot \dots = 0,25 \cdot 0,35 \cdot 5,5 \cdot 25 = 12,03 \text{ kN} \quad (\text{self-weight of the beam})$$

$$F_{adh} = A \cdot q = [(0,35 + 0,25 + 0,35) \cdot 5,5 + (0,35 \cdot 0,25) \cdot 2] \cdot 1 = 5,4 \text{ kN} \quad (\text{increase in self-weight due to adhesion to formwork})$$

Adhesion coefficient for formwork	
Smooth, oiled formwork	$q = 1 \text{ kN/m}^2$
Smooth, non-oiled formwork	$q = 2 \text{ kN/m}^2$
Rough formwork	$q = 3 \text{ kN/m}^2$

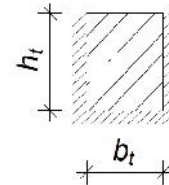

To minimize the labour consumption in production process, formwork on all sides of the panel is considered. This is also the worst case for calculation.

$$N_{d,1} = u \cdot \frac{\chi_{go}}{n \cdot \cos \gamma} \cdot (F_p + F_{adh}) = 1,3 \cdot \frac{1,35}{2 \cdot \cos 30} \cdot (12,03 + 5,4) = 11,26 \text{ kN} \quad (\text{force in one lifting clutch during formwork stripping})$$

$$N_{d,2} = u \cdot \frac{\chi_{go}}{n \cdot \cos \gamma} \cdot F_p = 2 \cdot \frac{1,35}{2 \cdot \cos 30} \cdot 12,03 = 13,13 \text{ kN} \quad (\text{force in one lifting clutch during manipulation on construction site})$$

$$N_d = \max(N_{d,1}; N_{d,2}) = \max(11,26; 13,13) = 13,13 \text{ kN}$$

During manipulation, the member is subjected to dynamic effects as well. These effects are taken into account by dynamic coefficient γ , which increases static effects. The size of dynamic coefficient is given by lifting device and its rectification.

Recommended values of dynamic coefficient	
Fixed crane, rail crane < 90m/min	1,0 – 1,2
Fixed crane, rail crane > 90m/min	1,3 – 1,4
Lifting and transport in flat terrain	1,5 – 1,65
Lifting and transport in rough terrain (construction site)	> 2,0

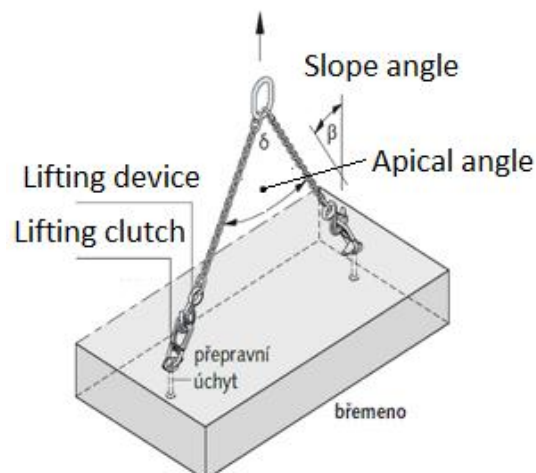
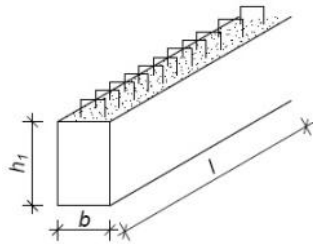

Fig. 8 Lifting of reinforced concrete panel

4.2. Number of connecting elements for manipulation



If the connecting reinforcement protrudes from the surface, they can be used for manipulation and no further lifting clutches are required.

Force in one leg of the connecting element

$$N = 0,6 \cdot \frac{N_d}{\cos(\alpha + 30)} = 0,6 \cdot \frac{13,13}{\cos(45 + 30)} = 21,56 \text{ kN}$$

$$t = 0,05 \cdot w + 0,3 = 0,05 \cdot 8 + 0,3 = 0,7$$

$$A_{s,req} = \frac{N_d}{t \cdot f_{yd}} = \frac{21,56}{0,7 \cdot 434,7} = 70,8 \text{ mm}^2$$

Cross-sectional area of one leg of stirrup is $\varnothing 8 = 50,3 \text{ mm}^2$

Required number of stirrups $n = 70,8/50,3 = 1,4 \Rightarrow 2$ kusy

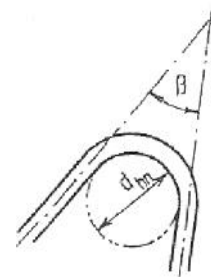

4.3. Check of beam during transport

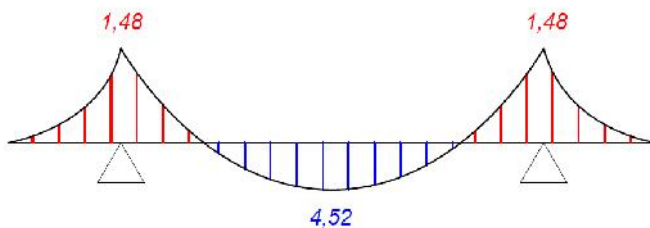

For manipulation, lifting clutches placed 1 m from the end of the beam will be used.

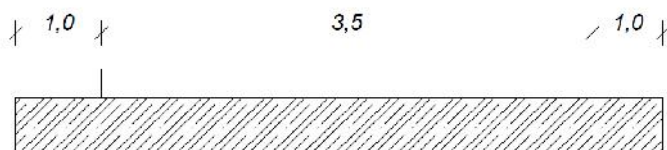

$$M_{Ed,v, poli} = 4,52 \text{ kNm}$$

$$d = h - c - \frac{22}{2} = 350 - 30 - \frac{22}{2} = 309 \text{ mm (only precast part is effective during transport)}$$

- Check of reinforcement

Návrh 3 $\varnothing 22$ ($A_{s,prov} = 1140 \text{ mm}^2$) (already designed)

$$x = \frac{A_{sd} \cdot f_{yd}}{0,8 \cdot b \cdot f_{cd}} = \frac{1140 \cdot 10^{-6} \cdot 434}{0,8 \cdot 0,25 \cdot 20,0} = 124 \text{ mm}$$

$$\xi = \frac{x}{d} = \frac{0,124}{0,309} = 0,40 \leq 0,617 = \xi_{max} \quad \text{CHECKED}$$

$$z = d - 0,4 \cdot x = 309 - 0,4 \cdot 124 = 256 \text{ mm}$$

$$M_{Rd} = A_s \cdot f_{yd} \cdot z = 1140 \cdot 10^{-6} \cdot 434 \cdot 0,256 = 128,34 \text{ kNm}$$

$$M_{Rd} = 128,34 \text{ kNm} \geq 4,52 \text{ kNm} = M_{Ed} \quad \text{CHECKED}$$

$$M_{Ed, \text{negative}} = 1,48 \text{ kNm}$$

- Design of support reinforcement

We choose 2Ø10 (*minimum beam reinforcement required by detailing rules*)

$$d = h - c - \frac{10}{2} = 350 - 30 - \frac{10}{2} = 315 \text{ mm (only precast part is effective during transport)}$$

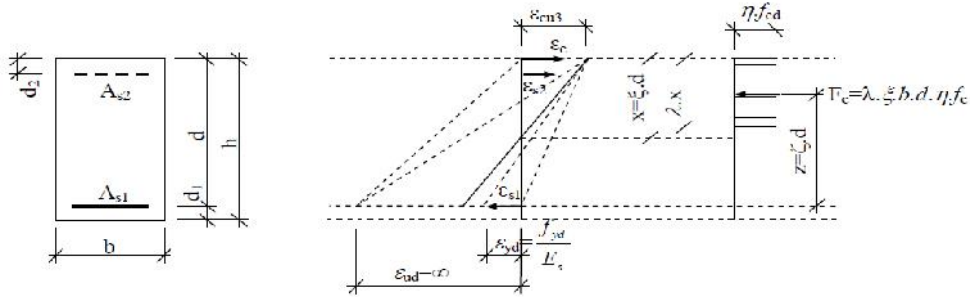

Fig. 9 Distribution of internal forces in beam (positive moment)

$$\eta = \frac{M_{Ed}}{b \cdot d^2 \cdot f_{cd}} = \frac{1,48}{0,25 \cdot 0,315^2 \cdot 20 \cdot 0,10^3} = 0,003 \Rightarrow \eta = 0,013$$

$$\zeta = 0,995$$

$$= 0,013 \quad 0,45 = \lim \quad \text{CHECKED}$$

$$A_{s, \text{req}} = \frac{M_{Ed}}{f_{yd} \cdot \eta \cdot d} = \frac{1,48 \cdot 10^3}{434 \cdot 10^6 \cdot 0,995 \cdot 0,315} = 10,8 \text{ mm}^2$$

- Check of reinforcement

Design: 2Ø10 ($A_{s, \text{prov}} = 157 \text{ mm}^2$)

$$x = \frac{A_{sd} \cdot f_{yd}}{0,8 \cdot b \cdot f_{cd}} = \frac{157 \cdot 10^{-6} \cdot 434}{0,8 \cdot 0,25 \cdot 20 \cdot 0,10^3} = 17 \text{ mm}$$

$$\xi = \frac{x}{d} = \frac{0,017}{0,315} = 0,05 \leq 0,617 = \xi_{\text{max}} \quad \text{CHECKED}$$

$$z = d - 0,4 \cdot x = 315 - 0,4 \cdot 17 = 308 \text{ mm}$$

$$M_{Rd} = A_s \cdot f_{yd} \cdot z = 157 \cdot 10^{-6} \cdot 434 \cdot 0,308 = 20,98 \text{ kNm}$$

$$M_{Rd} = 20,98 \text{ kNm} \geq 1,48 \text{ kNm} = M_{Ed} \quad \text{CHECKED}$$

4.4. Design of lifting clutches of filigree panel

$$F_p = V \cdot \dots = 0,05 \cdot 1,2 \cdot 2,5 \cdot 25 = 3,75 \text{ kN (self-weight of the panel)}$$

$$F_{adh} = A \cdot q = 1,2 \cdot 2,5 \cdot 1 = 3,25 \text{ kN (increase in self-weight due to adhesion to formwork)}$$

$$N_{d,1} = u \cdot \frac{x_{go}}{n \cdot \cos \Gamma} \cdot (F_p + F_{tah}) = 1,3 \cdot \frac{1,35}{2 \cdot \cos 30} \cdot (3,75 + 3,25) = 6,55 \text{ kN} \quad (\text{force in one lifting clutch during formwork stripping})$$

$$N_{d,2} = u \cdot \frac{x_{go}}{n \cdot \cos \Gamma} \cdot F_p = 2 \cdot \frac{1,35}{2 \cdot \cos 30} \cdot 3,25 = 4,09 \text{ kN} \quad (\text{force in one lifting clutch during manipulation on construction site})$$

$$N_d = \max(N_{d,1}; N_{d,2}) = \max(6,55; 4,09) = 6,55 \text{ kN}$$

- Required number of stirrups

$$N = 0,6 \cdot \frac{N_d}{\cos(s + 30)} = 0,6 \cdot \frac{6,55}{\cos(45 + 30)} = 9,25 \text{ kN}$$

$$t = 0,05 \cdot w + 0,3 = 0,05 \cdot 8 + 0,3 = 0,7$$

$$A_{s,req} = \frac{N_d}{t \cdot f_{yd}} = \frac{9,25}{0,7 \cdot 434,7} = 35,5 \text{ mm}^2$$

Cross-sectional area of one leg of stirrup $\text{Ø}6=28,3 \text{ mm}^2$

Required number of stirrups $n = 35,5/28,3=1,2 \Rightarrow 2$ kusy

5. Temporary supports during concreting

5.1. Filigree panel supports

Assembling loading

Permanent	Thickness [mm]	Bulk density [kg/m ³]	Char. load [kN/m ²]	Partial factor	Design load [kN/m ²]
In-situ concrete layer	100	2500	2,5	1,35	3,38
Filigree panel	50	2500	1,25	1,35	1,69
Total of permanent load		Σ	3,75	Σ	5,06
Variable					
Variable assembling load			0,75	1,5	1,13
Total of variable load		Σ	0,75	Σ	1,13
TOTAL		Σ	4,05	Σ	6,19

The standard determines variable load 0,75 kN/m² during assembling

The calculation is based on an assumption of one temporary support in the middle of span of filigree panel.

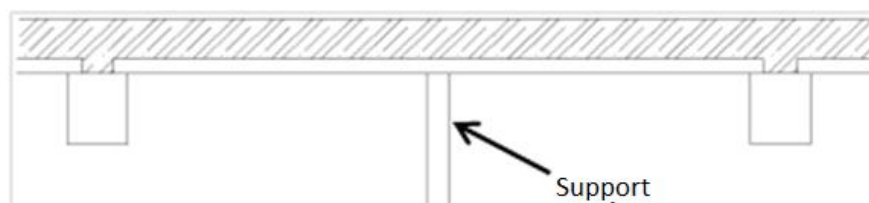

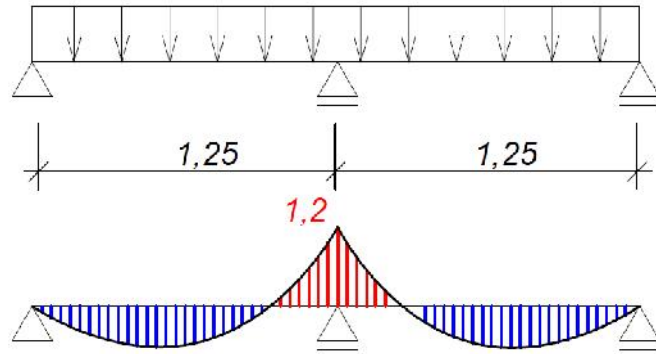

Fig. 10 Moment curve with temporary support

$$M_{Ed} = \frac{1}{8} \cdot (g + q)_d \cdot \left(\frac{l}{2}\right)^2 = \frac{1}{8} \cdot 6,19 \cdot \left(\frac{2,5}{2}\right)^2 = 1,20 \text{ kNm}$$

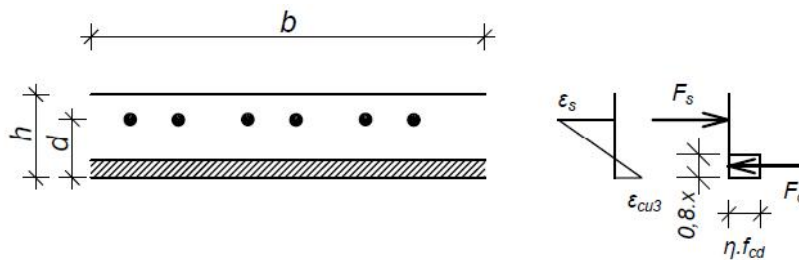

Fig. 11 Distribution of internal forces in slab (negative moment)

- Check of reinforcement in ULS

Ø10 per 300 mm ($A_{s,prov} = 262 \text{ mm}^2$) (already designed)

$$d = h - c - \varnothing / 2 = 50 - 20 - 8/2 = 26 \text{ mm}$$

$$x = \frac{A_{s,prov} \cdot f_{yd}}{b \cdot y \cdot f_{cd}} = \frac{262 \cdot 434,7}{0,8 \cdot 1000 \cdot 1,0 \cdot 20,0} = 7,1 \text{ mm}$$

$$\xi = \frac{x}{d} = \frac{7,1}{26} = 0,27 \leq 0,617 = \xi_{lim}$$

$$z = d - 0,5 \cdot x = 26 - 0,5 \cdot 7,1 = 23,2 \text{ mm}$$

$$m_{Rd} = a_{s,prov} \cdot f_{yd} \cdot z = 262 \cdot 434,7 \cdot 10^{-3} \cdot 0,023 = 2,6 \text{ kNm}$$

$$m_{Rd} = 2,6 \text{ kNm} \geq 1,20 \text{ kNm} = m_{Ed} \quad \text{CHECKED}$$

reserve 116%

One support in the midspan is required. Assumption checked.

5.2. Beam supports

Loading area $s = 2,5/2 = 1,25 \text{ m}$

$$M_{Ed} = \frac{1}{8} \cdot [(g + q)_d \cdot s] \cdot \left(\frac{l}{2}\right)^2 = \frac{1}{8} \cdot 6,19 \cdot 1,25 \cdot 5,5^2 = 29,25 \text{ kNm}$$

- Design of midspan reinforcement

$$d = h - c - \frac{22}{2} = 350 - 30 - \frac{22}{2} = 309 \text{ mm (only precast part is effective during transport)}$$

- Check of reinforcement

Design: 3 Ø22 ($A_{s,prov} = 1140 \text{ mm}^2$) (already designed)

$$x = \frac{A_{sd} \cdot f_{yd}}{0,8 \cdot b \cdot f_{cd}} = \frac{1140 \cdot 10^{-6} \cdot 434}{0,8 \cdot 0,25 \cdot 20,0} = 124 \text{ mm}$$

$$\xi = \frac{x}{d} = \frac{0,124}{0,309} = 0,40 \leq 0,617 = \xi_{\max} \quad \text{CHECKED}$$

$$z = d - 0,4 \cdot x = 309 - 0,4 \cdot 124 = 256 \text{ mm}$$

$$M_{Rd} = A_s \cdot f_{yd} \cdot z = 1140 \cdot 10^{-6} \cdot 434 \cdot 0,256 = 128,34 \text{ kNm}$$

$$M_{Rd} = 128,34 \text{ kNm} \geq 29,25 \text{ kNm} = M_{Ed} \quad \text{CHECKED}$$

The beam does not require temporary supports.